



Half Round Evaporators



PRODUCT DATA & INSTALLATION

Bulletin K30-R-PDI-18

Part # 1064042

	PRODUCT SUPPORT	
	web: k-rp.com/kruc	
	email: evaps@k-rp.com	
	call: 1-844-893-3222 x520	

High Temperature Applications
(35 °F and Higher)

Air Defrost

Electrical Power:
115/1/60, 208-230/1/60

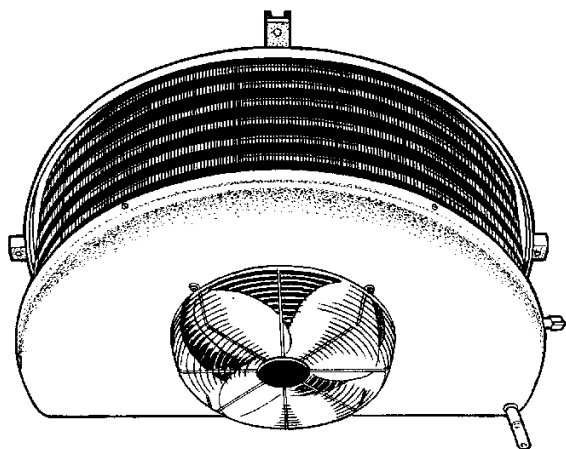

- Compatible with Low GWP Refrigerants
- Direct backwall location and minimum height provides maximum usable storage space.
- Textured heavy gauge aluminum cabinet - lightweight, doesn't show scratches.
- Rigid, slotted channel hangers simplify installation.
- Hinged drain pan for ease of cleaning and service.
- Full collar aluminum plate fins on expanded seamless copper tubes ensure optimum heat transfer efficiency.
- Fan motors are inherently protected
- Standard EC motors

NOMENCLATURE

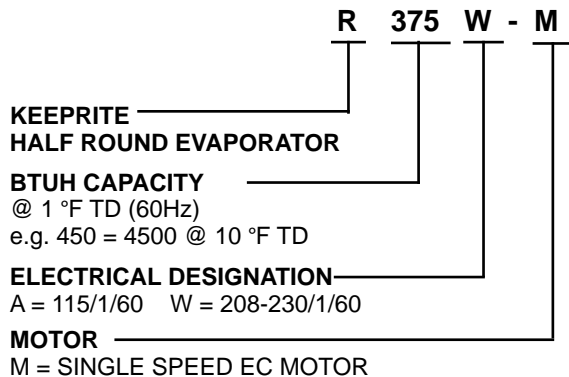

CONTENTS

PAGE

Nomenclature.....	Cover
Capacity Data.....	2
Electrical Data.....	2
Typical Field Wiring.....	2
Dimensional & Physical Data.....	3
Thermostatic Expansion Valve.....	4
Installation Instructions.....	5
Project Information.....	6
Product Support Resources.....	7
“As Built” Service Parts.....	Back

R

CAPACITY DATA - ALL MODELS

60Hz

Model R		375	485	595	775	905	1025	1305	2050	
Number of Fans		1	1	1	1	1	1	1	2	
Capacity BTUH (WATTS)	Evap Temp. 25°F (-4°C)	R407A	3540	4640	5750	7510	8460	9700	12200	19400
		R448A	(1038)	(1359)	(1684)	(2199)	(2478)	(2840)	(3563)	(5680)
		R407C	3360	4392	5445	7110	8010	9180	11600	18400
			(984)	(1287)	(1596)	(2084)	(2347)	(2690)	(3376)	(5381)
		R404A	3730	4880	6050	7900	8900	10200	12800	20400
			(1093)	(1430)	(1773)	(2315)	(2608)	(2989)	(3751)	(5979)
	R507	3540	4640	5750	7510	8500	9700	12200	19400	
		(1038)	(1359)	(1684)	(2199)	(2478)	(2840)	(3563)	(5680)	
	R22	3360	4392	5445	7110	8010	9180	11600	18400	
		(984)	(1287)	(1596)	(2084)	(2347)	(2690)	(3376)	(5381)	
	R134a	3360	4392	5445	7110	8010	9180	11600	18400	
		(984)	(1287)	(1596)	(2084)	(2347)	(2690)	(3376)	(5381)	
Air Flow	CFM (L/s)	770 (363)	770 (363)	1280 (604)	1300 (614)	1380 (651)	2025 (956)	2000 (944)	4050 (1911)	
Refrigerant ** Charge	Lbs (Kg)	1.4 (0.6)	1.9 (0.9)	2.3 (1.0)	3.3 (1.5)	3.6 (1.6)	4.1 (1.9)	5.3 (2.4)	8.3 (3.7)	

Capacities rated using 10°F (5.6°C) TD & 100°F (38°C) liquid temperature.

Capacities at other TD within a range of 8 to 15 °F (4.4 to 8.3°C) are directly proportional to TD, or use formula: Capacity = Rated capacity ÷ 10 x TD.

For capacities at TD outside of range 8 to 15 °F (4.4 to 8.3°C), or liquid temperature lower than 75°F (24°), consult factory.

Capacities for R448A, R407A and R407C are based on mean temperature. Mean temperature is the average temperature between the saturated suction temperature and the temperature feeding the evaporator. For dew point ratings, consult factory.

For R449A, use R448A data.

** REFRIGERANT CHARGE CONVERSION FACTORS

R448A	R407C	R404A	R507	R22	R134a
0.96	0.99	0.92	0.93	1.02	1.03

ELECTRICAL DATA

SINGLE SPEED EC MOTOR(S)

MODEL R	QTY.	POWER SUPPLY	HP	RPM	WATTS	TOTAL MOTOR FLA	MCA	MOP
375	1	115/1/60	1/20	1550	26	0.5	0.63	15
485	1	115/1/60	1/20	1550	26	0.5	0.63	15
595	1	115/1/60	1/20	1550	26	0.5	0.63	15
775	1	115/1/60	1/12	1070	84	1.5	1.88	15
905	1	115/1/60	1/12	1070	84	1.5	1.88	15
1025	1	115/1/60	1/12	1070	84	1.5	1.88	15
1305	1	115/1/60	1/12	1070	84	1.5	1.88	15
2050	2	115/1/60	1/12	1070	168	3.0	3.38	15
775	1	208-230/1/60	1/10	1070	86	1	1.25	15
905	1	208-230/1/60	1/10	1070	86	1	1.25	15
1025	1	208-230/1/60	1/10	1070	86	1	1.25	15
1305	1	208-230/1/60	1/10	1070	86	1	1.25	15
2050	2	208-230/1/60	1/10	1070	172	2	2.25	15

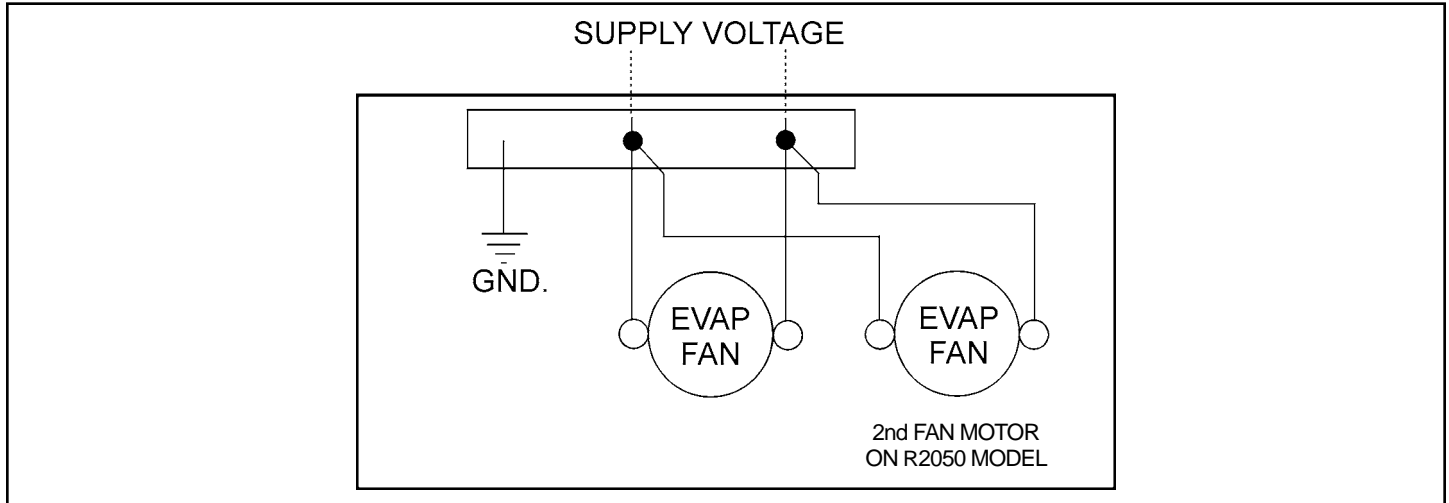

DIMENSIONAL AND PHYSICAL DATA

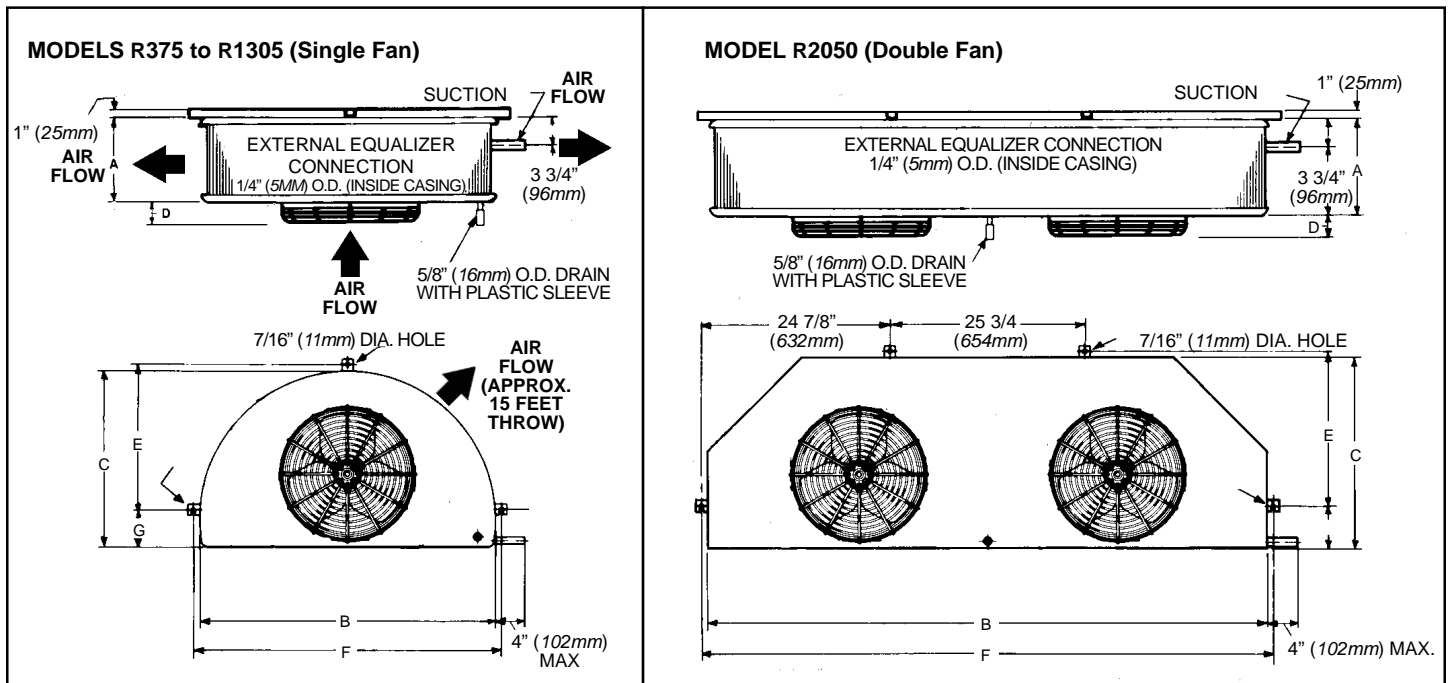

MODEL R		A	B	C	D	E	F	G	Suct. Conn. O.D.		Shipping Weight	
									in	mm	Lbs.	Kg.
375	in	8 1/8	33 1/4	20 3/4	2	16 3/4	34 3/4	4 3/4	5/8	15.9	72	32.7
485	mm	(206.4)	(844.6)	(527.0)	(50.8)	(425.5)	(882.7)	(120.7)	5/8	15.9	76	34.5
595	in	11 1/8	39 1/4	23 3/4	2 1/4	19 3/8	40 3/4	5 1/8	5/8	15.9	98	44.5
775	mm	(282.6)	(997.0)	(603.3)	(57.2)	(492.1)	(1035.0)	(130.2)	7/8	22.2	104	47.2
905	in	11 1/8	42 1/4	25 1/4	2 1/2	20 3/8	43 3/4	5 5/8	7/8	22.2	108	49
1025	in	12 5/8	42 1/4	25 1/4	2 1/2	20 3/8	43 3/4	5 5/8	7/8	22.2	114	51.2
1305	mm	(320.7)	(1073.1)	(641.4)	(63.5)	(417.5)	(1111.3)	(142.9)	7/8	22.2	124	56.2
2050	in	12 5/8	74	25 1/4	2 1/2	20 3/8	75 1/2	5 5/8	1 1/8	28.6	187	84.8
	mm	(320.7)	(1879.6)	(641.4)	(63.5)	(417.5)	(1917.5)	(142.9)				

NOTE: 5/8" (15.9 mm) O.D. Drain connection on all models.
1/2" (12.7 mm) Sweat TX Valve connection on all models.

R

THERMOSTATIC EXPANSION VALVE SELECTION CHART

60Hz

FOR +35°F ROOMS AND UP

AIR DEFROST		SPORLAN VALVE MODEL		
MODEL R	TD °F	R448A R407A R407C R22	R404A R507	R134a
375	10	SBFVE-AAA-C	SBFSE-AA-C	SBFJE-AA-C
	12	SBFVE-AAA-C	SBFSE-AA-C	SBFJE-AA-C
	15	SBFVE-AA-C	SBFSE-AA-C	SBFJE-AA-C
485	10	SBFVE-AA-C	SBFSE-AA-C	SBFJE-AA-C
	12	SBFVE-AA-C	SBFSE-AA-C	SBFJE-AA-C
	15	SBFVE-AA-C	SBFSE-A-C	SBFJE-A-C
595	10	SBFVE-AA-C	SBFSE-AA-C	SBFJE-AA-C
	12	SBFVE-AA-C	SBFSE-A-C	SBFJE-A-C
	15	SBFVE-AA-C	SBFSE-A-C	SBFJE-A-C
775	10	SBFVE-AA-C	SBFSE-A-C	SBFJE-A-C
	12	SBFVE-AA-C	SBFSE-A-C	SBFJE-A-C
	15	SBFVE-A-C	SBFSE-A-C	SBFJE-A-C
905	10	SBFVE-AA-C	SBFSE-A-C	SBFJE-A-C
	12	SBFVE-A-C	SBFSE-A-C	SBFJE-A-C
	15	SBFVE-A-C	SBFSE-A-C	SBFJE-A-C
1025	10	SBFVE-AA-C	SBFSE-A-C	SBFJE-A-C
	12	SBFVE-A-C	SBFSE-A-C	SBFJE-A-C
	15	SBFVE-A-C	SBFSE-B-C	SBFJE-B-C
1305	10	SBFVE-A-C	SBFSE-A-C	SBFJE-A-C
	12	SBFVE-A-C	SBFSE-B-C	SBFJE-B-C
	15	SBFVE-A-C	SBFSE-B-C	SBFJE-B-C
2050	10	SBFVE-A-C	SBFSE-B-C	SBFJE-B-C
	12	SBFVE-B-C	SBFSE-B-C	SBFJE-B-C
	15	SBFVE-B-C	SBFSE-C-C	SBFJE-C-C

Selections based on 100° Liquid

For R449A, use R448A data.

APPLICATION

High Temp Evaporators are designed for use with a wide variety of popular refrigerants. At room temperatures above 34°F and evaporating temps no lower than 27°F the air flowing through the coil will accomplish the defrost. Temperatures of 34°F and below (to -40°F) require positive defrosting. (either Electric or Hot Gas). The coil must not be exposed to any abnormal atmospheric or acidic environments. This may result in corrosion to the cabinet and possible coil failure (leaks). (Consult manufacturer for optional baked on phenolic protective coatings).

INSTALLATION

The installation and start-up of evaporators should only be performed by qualified refrigeration mechanics. This equipment should be installed in accordance with all applicable codes, ordinances and local by-laws.

INSPECTION

Inspect all equipment before unpacking for visible signs of damage or loss. Check shipping list against material received to ensure shipment is complete.

IMPORTANT: Remember, you, the consignee, must make any claim necessary against the transportation company. Shipping damage or missing parts, when discovered at the outset, will prevent later unnecessary and costly delays. **If damage or loss during transport is evident, make claim to carrier, as this will be their responsibility, not the manufacturer's.**

Should carton be damaged, but damage to equipment is not obvious, a claim should be filed for "concealed damage" with the carrier.

IMPORTANT: The electrical characteristics of the unit should be checked at this time to make sure they correspond to those ordered and to electrical power available at the job site. Save all shipping papers, tags and instruction sheets for reference by installer and owner.

LOCATION

The unit location in the room should be selected to ensure uniform air distribution throughout the entire space to be refrigerated. Make sure that the air is not blown directly out through the opened door and that the product does not obstruct the free circulation of air.

NOTE: These units drawn air through the fan and discharge air from the coil side.

When installing the unit adjacent to a wall sufficient clearance (2" (50mm) minimum) must be provided to allow the hinged drain pan to be lowered for servicing the unit. Channel type hangers are provided. Rear hangers are slotted to facilitate installation. See dimensional data.

MOUNTING

Mounting brackets with 7/16" dia holes are provided for flush mounting to the ceiling. For details refer to dimensional data on page 3.

Ensure that the ceiling is level since the drain pan has been sloped for drainage during the defrost cycle.

DRAIN LINE

The drain line should be run from the drain connection, sloping at least 4" per foot. A trap outside the room will prevent warm air from entering through the tubing.

Connection should be made to proper drainage facilities that comply with local regulations.

Ensure that the drain pan has sufficient slope for proper drainage (prevention of ice build up/blockage in pan).

PIPING

Refrigerant line sizes are important and may not be the same size as the coil connections. (depends on the length of run) If in doubt, consult "Recommended refrigerant line sizes" charts. (Engineering Manuals or other recognized sources of information).

WIRING

Wire system in accordance with governing standards and local codes. See data and wiring diagram on pages 2-3, for wiring arrangement. Electrical wiring is to be sized in accordance with minimum ampacity rating.

SYSTEM CHECK

Before Start-Up:

1. All wiring should be in accordance with local codes.
2. Refrigerant lines should be properly sized.
3. Off-cycle defrost systems should include a liquid line solenoid valve.
4. Thorough evacuation and, dehydration has been performed.
5. The suction, discharge, and receiver service valves must be open.
6. The system should include a liquid line drier moisture indicator and suction filter.
7. Pour enough water into the drain pan to allow a good check on drainage and seal the trap.

After Start-Up:

1. Check the compressor oil level to ensure the correct oil charge.
2. Be sure that the expansion valve is properly set to provide the correct amount of superheat.
3. Heavy moisture loads are usually encountered when starting the system for the first time.
4. Check for proper evaporator fan blade rotation.

MAINTENANCE

The unit should be periodically inspected for any dirt or build-up on the fin surface and cleaned if necessary with a soft whisk or brush.

R

PROJECT INFORMATION

60Hz

System	
Model Number	Date of Start-Up
Serial Number	Service Contractor
Refrigerant	Phone
Electrical Supply	E-Mail

 <p>PRODUCT SUPPORT</p>	<p><i>web:</i> k-rp.com/kruc <i>email:</i> evaps@k-rp.com <i>call:</i> 1-844-893-3222 x520</p>
--	---

 <p>TROUBLESHOOTING</p>	<p><i>email:</i> troubleshooting@k-rp.com <i>call:</i> 1-844-893-3222 x529</p>
--	--

 <p>SERVICE PARTS</p>	<p><i>web:</i> k-rp.com/parts <i>email:</i> parts@k-rp.com <i>call:</i> 1-844-893-3222 x501</p>
--	---

 <p>WARRANTY</p>	<p><i>web:</i> k-rp.com/warranty <i>email:</i> warranty@k-rp.com <i>call:</i> 1-844-893-3222 ext. 501</p>
--	---

 <p>ORDERS</p>	<p><i>email:</i> orders@k-rp.com <i>call:</i> 1-844-893-3222 x501</p>
---	--

 <p>SHIPPING</p>	<p><i>email:</i> shipping@k-rp.com <i>call:</i> 1-844-893-3222 x503</p>
---	--

“AS BUILT” SERVICE PARTS LIST

Service Parts List
Label
To Be Attached
HERE



NATIONAL REFRIGERATION &
AIR CONDITIONING CANADA CORP.
159 ROY BLVD., BRANTFORD, ON, N3R 7K1



1-800-463-9517 (519) 751-0444
www.k-rp.com info@k-rp.com fax: (519) 753-1140