



KCC Centrifugal Fan Air Cooled Condensers

PRODUCT DATA & INSTALLATION

Bulletin K50-KCC-PDI-10

1064435

We are on the Internet  www.keepriterefrigeration.com

Air Cooled Models from 103 Thru 164
Four to ninety Ton

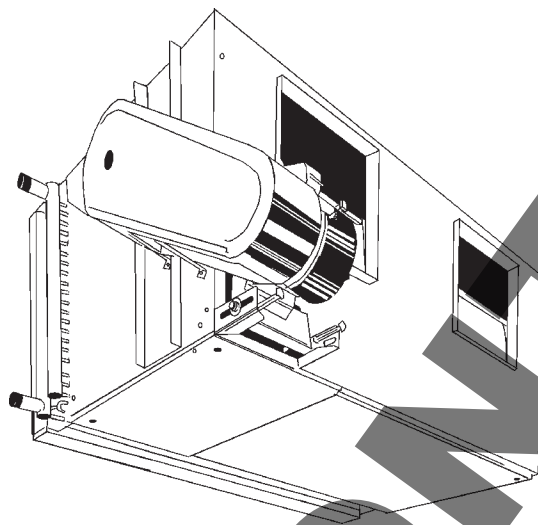

- Galvanized steel, angular steel frame cabinet construction
- Removable access panels
- Galvanized steel fan housings and wheels.
- 12" (305mm) diameter fan wheels keyed to fan shaft
- Direct drive fan motors with inherent overload protection.
- Weather protected motors with top end rain shields and shaft moisture slingers.
- High efficiency rippled aluminum fin coils
- Adjustable motor bases and drives

NOMENCLATURE

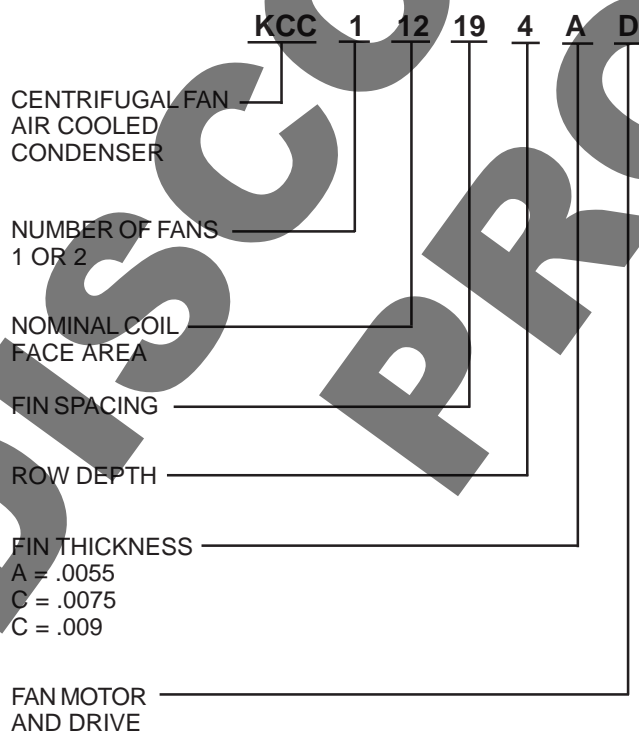

CONTENTS PAGE

Nomenclature.....	Cover
Capacity Data.....	2
Fan Data.....	2
Selection Data.....	3
Dimensional Data.....	5,6
Installation Instructions.....	7,8
Design Specifications.....	9
Service Log.....	Back
Project Information.....	Back

CAPACITY DATA

TABLE 2

		R-22					
		TOTAL HEAT REJECTION (BTU/HR)					
KCC MODEL NO.	°F. (°C) TEMPERATURE DIFFERENCE = CONDENSING TEMPERATURE MINUS AMBIENT TEMPERATURE						
	1 (.6)	10 (6)	15 (8)	20 (11)	25 (14)	30 (17)	
103	1800	18000	27000	36000	45000	54000	
104	2730	27300	41000	54600	68300	82000	
106	3900	39000	58500	78000	97500	117000	
108	5200	52000	78000	104000	130000	156000	
111	6930	69300	104000	138600	173300	208000	
214	8860	88600	133000	177300	221600	266000	
217	10500	105000	157500	210000	262500	315000	
222	13030	130300	195500	260600	325800	391000	
228	16360	163600	245500	327300	409100	491000	
237	21460	214600	321900	429200	536600	643800	
141	25200	252000	378000	504000	630000	756000	
150	28980	289800	434700	579600	724500	869400	
164	36580	365800	548700	731600	914500	1097400	

TABLE 2

		R-404A					
		TOTAL HEAT REJECTION (BTU/HR)					
KCC MODEL NO.	°F. (°C) TEMPERATURE DIFFERENCE = CONDENSING TEMPERATURE MINUS AMBIENT TEMPERATURE						
	1 (.6)	10 (6)	15 (8)	20 (11)	25 (14)	30 (17)	
103	1750	17500	26250	35000	43750	52500	
104	2650	26500	39750	53000	66250	79500	
106	3780	37800	56700	75600	94500	113400	
108	5040	50400	75600	100800	126000	151200	
111	6720	67900	100800	134400	168000	201600	
214	8590	85900	128850	171800	214750	257700	
217	10190	101900	152850	203800	254750	305700	
222	12640	126400	189600	252800	316000	379200	
228	15870	158700	238050	317400	396750	476100	
237	20820	208200	312300	416400	520500	624600	
141	24440	244400	366600	488800	611000	733200	
150	28110	281100	421650	562200	702750	843300	
164	35480	354800	532200	709600	887000	1064400	

FAN DATA

TABLE 3

MODEL NO.	NOMINAL C.F.M.	STANDARD 6 ROW COIL ONLY		TOTAL STATIC PRESSURE (Includes Coil, Ductwork etc.)													
				.55		.75		1.00		1.25		1.50		1.75		2.00	
		R.P.M.	B.H.P.	R.P.M.	B.H.P.	R.P.M.	B.H.P.	R.P.M.	B.H.P.	R.P.M.	B.H.P.	R.P.M.	B.H.P.	R.P.M.	B.H.P.	R.P.M.	B.H.P.
103	2000	1077	0.65	1167	0.72	1272	0.81	1371	0.91	1465	1.01	1555	1.12	1644	1.23		
104	3150	810	1.16	870	1.25	930	1.37	1007	1.49	1075	1.57	1136	1.66	1195	1.98		
106	4500	910	1.76	948	1.89	996	2.06	1045	2.25	1096	2.44	1148	2.65	1202	2.87		
108	6000	680	2.00	716	2.15	765	2.42	813	2.71	863	3.02	911	3.33	960	3.66		
111	8000	658	3.05	691	3.28	727	3.60	767	3.95	808	4.35	850	4.78	894	5.23		
214	10000	800	3.63	842	3.98	900	4.40	956	4.84	1012	5.30	1066	5.77	1120	6.27		
217	12000	706	4.15	744	4.54	795	5.05	846	5.59	897	6.15	948	6.74	998	7.36		
222	15000	655	5.42	689	5.89	734	6.53	780	7.20	825	7.91	869	8.64	913	9.40		
228	19000	505	6.15	533	6.79	573	7.68	613	8.61	653	9.60	691	10.62	729	11.68		
237	23000	447	7.22	473	7.88	511	8.97	547	10.10	584	11.27	619	12.47	653	13.70		
141	29000	338	10.55	355	11.73	370	13.14	397	14.53	420	15.92	442	17.28	463	18.68		
150	34000	285	11.17	301	12.39	326	1.398	350	15.57	372	17.20	393	18.85	413	20.55		
164	42000	263	14.58	279	16.03	300	18.12	321	20.18	340	22.20	363	24.24	376	26.27		

SELECTION DATA

The selection of an air cooled condenser is based on the heat rejection capacity at the condenser rather than net refrigeration effect at the evaporator because the refrigerant gas absorbs additional energy in the compressor. This additional energy, the heat of compression, varies appreciably with the operating conditions of the system and with compressor design, whether open or suction cooled hermetic type.

Some compressor manufacturers publish heat rejection figures as part of their compressor ratings. Since heat rejection varies with compressor design, it is recommended that the compressor manufacturer's data be used whenever available in selecting an air cooled condenser.

If the compressor manufacturer does not publish heat rejection ratings, factors from Table Nos. 4 and 5 may be used to estimate total heat rejection-THR.

For systems outside the normal limits of single stage compressor application, (such as compound or cascade refrigeration systems) the following formulas may be used to arrive at the heat rejection requirements for selection of the condenser:

Open Compressors

$$\text{THR} = \text{Compressor Capacity (Btuh)} + 2545 \times \text{Bhp}$$

Suction Cooled Hermetic Compressors

$$\text{THR} = \text{Compressor Capacity (Btuh)} + 3413 \times \text{KW}$$

HEAT REJECTION FACTORS

CONDENSER LOAD = COMPRESSOR CAPACITY X FACTOR

OPEN COMPRESSORS

TABLE NO. 4

EVAPORATOR TEMP		CONDENSING TEMPERATURE °F. (°C.)					
°F.	°C.	90 (32)	100 (38)	110 (43)	120 (49)	130 (54)	140 (60)
-30	-34	1.37	1.42	1.47	*	*	*
-20	-29	1.33	1.37	1.42	1.47	*	*
-10	-23	1.28	1.32	1.37	1.42	1.47	*
0	-18	1.24	1.28	1.32	1.37	1.41	1.47
10	-12	1.21	1.24	1.28	1.32	1.36	1.42
20	-7	1.17	1.20	1.24	1.28	1.32	1.37
30	-1	1.14	1.17	1.20	1.24	1.27	1.32
40	4	1.12	1.15	1.17	1.20	1.23	1.28
50	10	1.09	1.12	1.14	1.17	1.20	1.24

* Outside of normal limits for single stage compressor application. For two stage application use formulas above.

SUCTION COOLED HERMETIC COMPRESSORS

TABLE NO. 5

EVAPORATOR TEMP		CONDENSING TEMPERATURE °F. (°C.)					
°F.	°C.	90 (32)	100 (38)	110 (43)	120 (49)	130 (54)	140 (60)
-30	-34	1.57	1.62	1.68	*	*	*
-20	-29	1.49	1.53	1.58	1.65	*	*
-10	-23	1.42	1.46	1.50	1.57	1.64	*
0	-18	1.36	1.40	1.44	1.50	1.56	1.62
10	-12	1.31	1.34	1.38	1.43	1.49	1.55
20	-7	1.26	1.29	1.33	1.37	1.43	1.49
30	-1	1.22	1.25	1.28	1.32	1.37	1.42
40	4	1.18	1.21	1.24	1.27	1.31	1.35
50	10	1.14	1.17	1.20	1.23	1.26	1.29

* Outside of normal limits for single stage compressor application. For two stage application use formulas above.

SELECTION EXAMPLE

GIVEN:

Compressor Capacity 350,000 Btuh
 Evaporator Temperature 40°F.
 Refrigerant R-22
 Ambient Air 95°F.
 Maximum Condensing Temperature 120°F.
 Suction Cooled Hermetic Compressor

PROCEDURE:

- Assuming the compressor manufacturer's heat rejection data is not available, determine the heat rejection factors for the specified conditions from Table No. 5 above (1.27).
- Multiply the compressor capacity by the heat rejection factor to estimate the required condenser capacity.

- Since R-22 is specified, select the proper condenser from Table No. 1 based on the specified difference between condensing refrigerant and the ambient air (T.D.).

SELECTION:

Using the heat rejection factor from Table No. 5 above, the required condenser capacity is:

$$1.27 \times 350,000 = 444,000 \text{ Btuh}$$

From Table No. 1 for the specified T.D. of 25°F the proper selection is the Model KCC 237 with a capacity of 536,600 Btuh. In this instance the condenser is slightly oversized and the condenser will balance the compressor heat rejection at less than the maximum condensing temperature of 120°F.

MULTIPLE COMPRESSOR APPLICATIONS

Multi-section units are available for applications where more than one compressor is used either on the same system or separate systems. Usually, this arrangement will result in lower installation costs as opposed to using separate units. Coils for multi-section condensers are factory circuited

and divided into the proper number of sections, each sized to meet the specified capacity. Each circuit is supplied with a hot gas inlet and liquid outlet connection and tagged for identification. The fan on a multi-section unit should remain operative as long as a condensing requirement exists in any section of the coil.

TABLE 6 HEAT REJECTION CAPACITY PER FACE TUBE (BTU / HR) - R12

KCC MODEL NO.	FACE TUBES	°F. (°C) TEMPERATURE DIFFERENCE = CONDENSING TEMPERATURE MINUS AMBIENT TEMPERATURE					
		1 (6)	10 (6)	15 (8)	20 (11)	25 (14)	30 (17)
103	12	150	1502	2252	3003	3754	4505
104	14	194	1943	2914	3885	4856	5828
106	16	245	2447	3670	4893	6116	7340
108	22	236	2363	3544	4725	5906	7088
111	22	315	3150	4725	6300	7875	9450
214	22	402	4022	6032	8043	10054	12065
217	22	477	4767	7151	9534	11918	14301
222	26	500	4998	7479	9996	12495	14994
228	26	630	6300	9450	12600	15750	18900
237	34	630	6300	9450	12600	15750	18900
141	40	630	6300	9450	12600	15750	18900
150	46	630	6300	9450	12600	15750	18900
164	58	626	6258	9387	12516	15646	18774

For R-404A ratings, multiply above capacities by 0.97.

SELECTION EXAMPLE

GIVEN:

Six hermetic compressors with capacities and evaporator temperatures (tabulated below).
 Refrigerant R-22
 Ambient Air Temperature 100°F.
 Maximum Condensing Temperature 120°F.

PROCEDURE:

1. Tabulate the compressor capacities, evaporator temperatures and heat rejection factors for each compressor. (See Sample Tabulation, below.)
2. Determine the required heat rejection capacity for each compressor.
3. Total the sectional heat rejection capacities for the six compressors.

SELECTION:

Based on the total heat rejection capacity for the six compressors of 186,160 Btuh, it can be seen from Table No. 6 that the smallest unit which will meet this requirement is the Model KCC217 with 210,000 Btuh

at 20 °F. T.D. Table No. 6 lists the heat rejection capacity per "face tube" at various T.D.'s.

At 20 °F. T.D., the KCC 217 has a capacity of 9534 Btuh per "face tube". To determine the required number of face tubes for each section, divide the required sectional capacity by the capacity per "face tube". For example, compressor No. 1 requires $18,000 \div 9534 = 2$ "face tubes". Section No. 1 should be eircuited with 2 "face tubes" for Compressor No. 1. Following this same procedure will determine the size of each section for the remaining compressors.

The sample tabulation shows the results of this selection and indicates that 22 "face tubes" are required when using the Model KCC 217. Since the Model KCC 217 has 22 "face tubes" available, the selection has been satisfied. If the total required number of "face tubes" exceeds the number of "face tubes" available as listed in Table No. 6 it will be necessary to permit a slightly higher condensing temperature than planned for one or two of the sections. A second alternative would be to select the next larger size condenser.

SAMPLE TABULATION

COMPRESSOR NO.	COMPRESSOR CAPACITY (BTUH)	EVAPORATOR TEMPERATURE		HEAT REJECTION FACTOR	REQUIRED CONDENSER CAPACITY (BTUH)	REQUIRED NUMBER OF FACE TUBES
		°F.	°C.			
1	13500	+20	-7	1.37	18000	2
2	10000	-15	-23	1.57	17440	2
3	36000	+15	-9	1.40	51400	6
4	11000	+20	-7	1.37	15070	2
5	31000	-10	-23	1.57	50000	6
6	25000	+20	-7	1.37	34250	4
					<u>186160</u>	<u>22</u>

DIMENSIONAL DATA

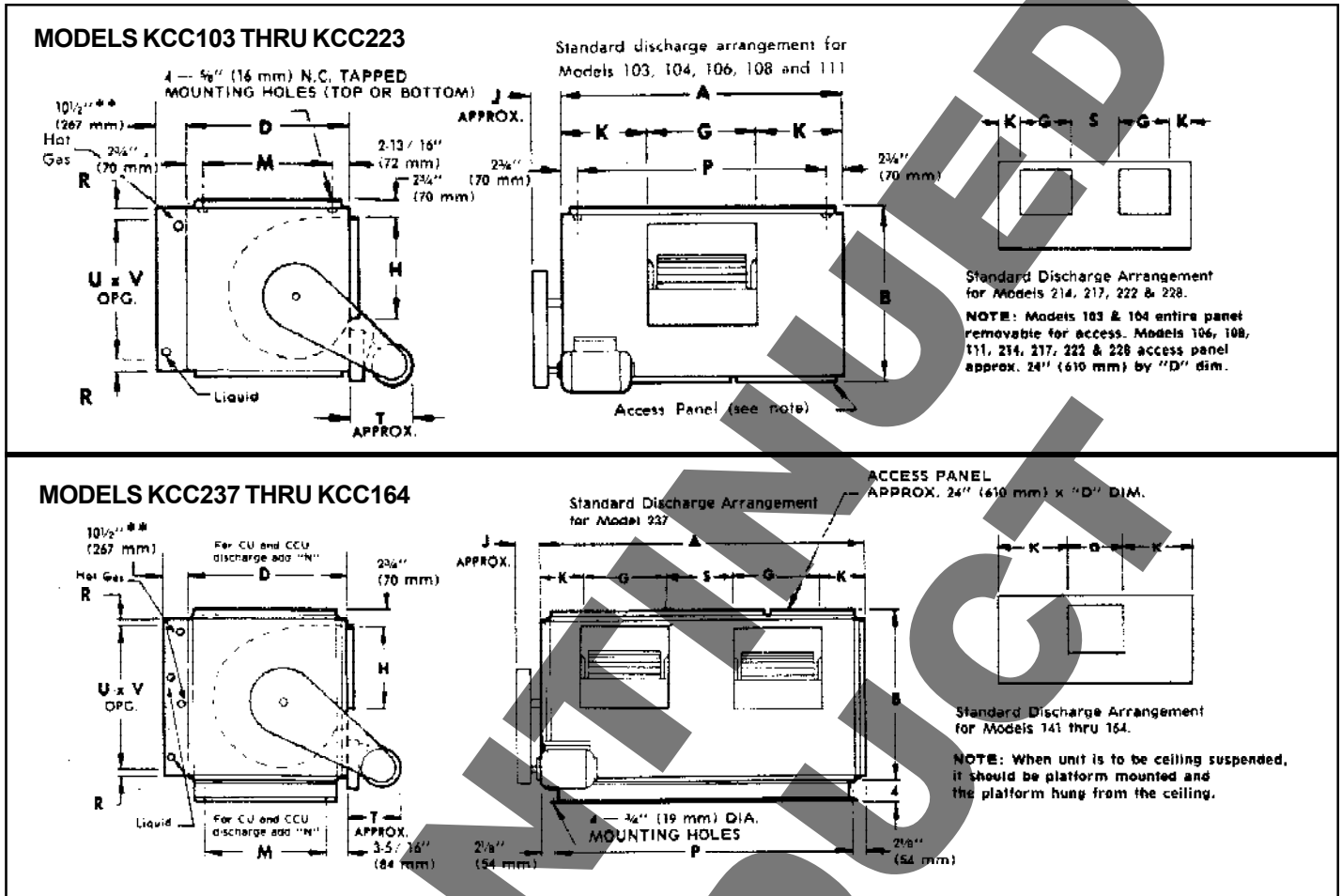

DIMENSIONS - GENERAL DATA

MODEL No. KCC		A	B	D	G	H	J	K	M	N	P	R	S	T	U	V	No. of FACE TUBES	REFRIGERANT* CHARGE 6 ROW COIL				SHIPPING WEIGHT	
																		R-12		R-22		Lbs.	kg
																		Lbs.	kg.	Lbs.	kg		
103	ins.	34	22 3/4	21 3/4	11 3/4	10 1/4	6 1/2	11 1/8	16 1/8	-	28 1/2	1 1/2	-	15	18	30	12	3.31	1.50	2.98	1.35	343	156
	mm	864	578	553	299	260	165	283	410	-	724	38	-	381	457	762							
104	ins.	40	25 3/4	24 3/4	12 1/4	13 1/2	6 1/2	13 7/8	19 1/8	-	34 1/2	1 1/2	-	15	21	36	14	4.50	2.04	4.05	1.84	431	196
	mm	1016	654	629	311	343	165	352	486	-	876	38	-	381	533	914							
106	ins.	50	29	28	17 1/4	15 7/8	6 1/2	16 3/8	22 3/8	-	44 1/2	1 1/2	-	16	24	45	16	5.85	2.66	5.27	2.39	600	272
	mm	1270	737	711	438	403	165	416	568	-	1130	38	-	406	610	1143							
108	ins.	48	37 3/4	36 3/4	21 1/8	19 3/8	8	13 3/8	31 1/8	-	42 1/2	1 1/2	-	18	33	44	22	7.88	3.58	7.09	3.22	806	366
	mm	1219	959	934	537	492	203	340	791	-	1080	38	-	457	838	1118							
111	ins.	63	37 3/4	36 3/4	23 1/4	21 5/8	8	19 7/8	31 1/8	-	57 1/2	1 1/2	-	18	33	58	22	10.28	4.67	9.25	4.20	996	452
	mm	1600	959	934	591	549	203	505	791	-	1461	38	-	457	838	1473							
214	ins.	78	37 3/4	36 3/4	19 17/8	17 7/8	8	10	31 1/8	-	72 1/2	1 1/2	20	21	33	74	22	13.02	5.91	11.72	5.32	1171	531
	mm	1981	959	934	483	454	203	254	791	-	1842	38	508	533	838	1880							
217	ins.	93	37 3/4	36 3/4	21 1/8	19 3/8	8	12 3/4	31 1/8	-	87 1/2	1 1/2	25 3/8	21	33	88	22	14.20	6.45	12.90	5.86	1393	632
	mm	2362	959	934	537	492	203	324	791	-	2223	38	645	533	838	2235							
222	ins.	97	44 3/4	43 3/4	23 1/4	21 5/8	9	12 5/8	38 1/8	-	91 1/2	2	25 1/4	21	39	92	26	17.46	7.93	15.86	7.20	1714	778
	mm	2464	1137	1111	591	549	229	321	968	-	2324	51	641	533	991	2337							
228	ins.	120	44 3/4	43 3/4	28 1/4	26 1/2	9	15 7/8	38 1/8	-	114 1/2	2	31 3/4	23	39	116	26	21.55	9.78	19.59	8.89	2163	981
	mm	3048	1137	1111	718	673	229	403	968	-	2908	51	807	584	991	2946							
237	ins.	122 1/8	57 3/8	45 5/8	31 1/2	28 3/4	11 1/2	15 1/8	39 1/2	11 3/4	117 7/8	2	29	25	51	116	34	28.72	13.04	26.10	11.85	3420	1551
	mm	3102	1457	1159	800	730	292	384	1003	299	2994	51	737	635	1295	2946							
141	ins.	122 1/8	65 5/8	59 1/8	46 3/8	43 1/4	11 1/2	37 7/8	53	6 1/2	117 7/8	1 3/4	-	25	60	116	40	34.29	15.57	31.15	14.14	3500	1588
	mm	3102	1667	1502	1178	1099	292	962	1346	165	2994	45	-	635	1524	2946							
150	ins.	122 1/8	75 3/8	66 5/8	51 1/2	47 1/4	11 1/2	35 3/8	60 1/2	8 3/4	117 7/8	2	-	25	69	116	46	41.28	18.74	38.05	17.27	4500	2041
	mm	3102	1915	1692	1308	1200	292	899	1537	222	2994	51	-	635	1753	2946							
164	ins.	122 1/8	93 3/8	72 5/8	56 3/4	52 3/8	11 1/2	32 5/8	66 1/2	20 3/4	117 7/8	2	-	25	87	116	58	53.31	24.20	47.98	21.78	5900	2676
	mm	3102	2372	1845	1442	1330	292	829	1689	527	2994	51	-	635	2210	2946							

* For R502 multiply charge in lbs. by 0.93 and for R500 by 0.88. For winter charge, multiply by 6.65.

** For filter section dimensions refer to page 7.

MULTIPLE CIRCUIT CONNECTION SIZES

NET TONS		0 - 7 1/2 †	8-10	11-13	14-18	19-28	29-35	36-43	44-57	58-64	65-72	73 & up
HOT GAS INLET	ins.	1 1/8	1 3/8	1 3/8	1 5/8	2 1/8	2 1/8	2 5/8	2 5/8	3 1/8	3 1/8	3 5/8
	mm	29	35	35	41	54	54	67	67	79	79	92
LIQUID OUTLET	ins.	7/8	7/8	1 1/8	1 1/8	1 3/8	1 5/8	1 5/8	2 1/8	2 1/8	2 5/8	2 5/8
	mm	22	22	29	29	35	41	41	54	54	67	67

FAN DISCHARGE ARRANGEMENTS MOTOR & ACCESS PANEL LOCATIONS (Viewed from Drive End)

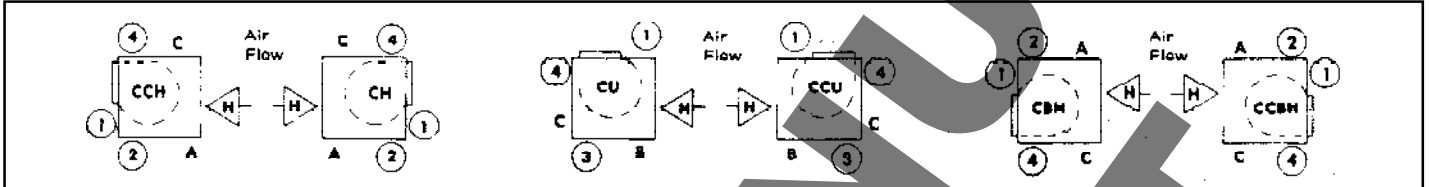

NOTE: Models 237 thru 164 only available with CU and CCU discharge arrangement when furnished with a special "square" fan cabinet. Not available with motor location or access location on bottom.

FILTER SECTIONS

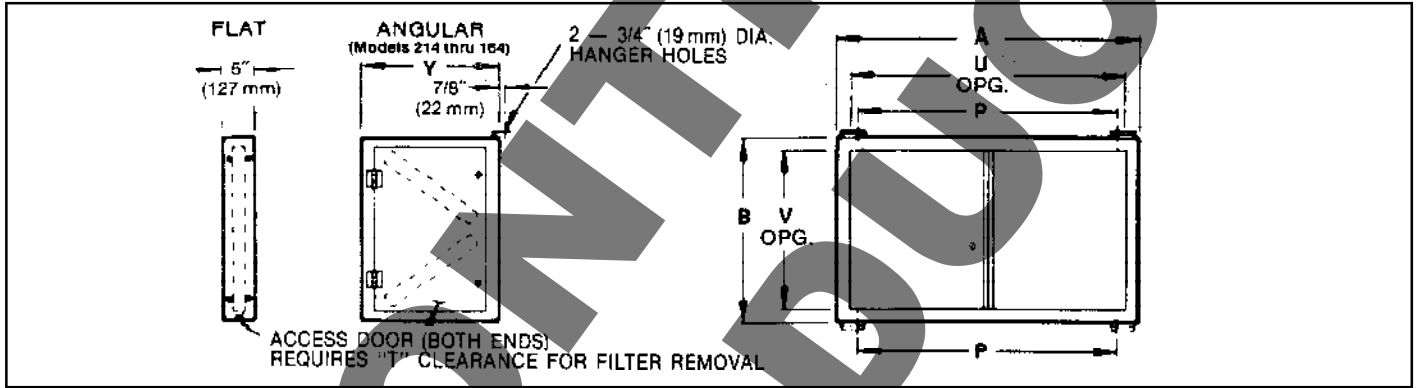

UNIT SIZE	A		B		P		FILTER SECTIONS												SHIPPING WEIGHTS					
							FLAT				ANGULAR								Flat		Angular			
	ins	mm	ins	mm	ins	mm	T	U	V	Y	T	U	V	Y	T	U	V	Y	lb	kg	lb	kg		
103	34	864	21 5/8	549	28 1/2	724	16 1/2	419	30 5/8	778	17 5/8	448							39	18				
104	40	1016	24 5/8	626	34 1/2	876	20 1/2	521	36 5/8	930	20	508							49	22				
106	50	1270	27 7/8	708	44 1/2	1130	16 1/2	419	45 5/8	1184	23 1/8	587	NA	NA	NA	NA	NA	NA	62	28	NA	NA		
108	48	1219	36 5/8	930	42 1/2	1080	25 1/2	648	44 5/8	1133	32 1/2	826							86	39				
111	63	1600	36 5/8	930	57 1/2	1461	20 1/2	521	59 5/8	1514	32 1/2	826							118	54				
214	78	1981	36 5/8	930	72 1/2	1842	25 1/2	648	74 5/8	1895	32 1/2	826	26	660	74 5/8	1895	33 1/4	845	26	660	140	64	305	138
217	93	2362	36 5/8	930	87 1/2	2223	25 1/2	648	89 5/8	2276	32 1/2	826	26	660	89 5/8	2276	33 1/4	845	26	660	161	73	348	158
222	97	2464	48 5/8	1108	91 1/2	2324	16 1/2	419	93 5/8	2378	40 1/8	1019	23	584	93 5/8	2378	40 1/4	1022	23	584	189	86	377	171
228	120	3048	43 5/8	1108	114 1/2	2908	20 1/2	521	116 5/8	2962	40 1/8	1019	23	584	116 5/8	2962	40 1/4	1022	23	584	232	105	449	204
237	119 3/8	3032	55 1/8	1400	117 7/8	2994	20 1/2	521	116 5/8	2962	50 1/8	1273	25 1/2	648	115 1/8	2934	51 3/4	1314	22 1/4	565	278	126	675	283
141	119 3/8	3032	63 3/8	1610	117 7/8	2994	20 1/2	521	116 5/8	2962	60 1/8	1527	21 1/8	536	115 1/8	2934	60	1524	21 1/8	536	303	137	656	298
150	119 3/8	3032	73 1/8	1857	117 7/8	2994	20 1/2	521	116 5/8	2962	70 1/8	1781	25 1/2	648	115 1/8	2934	69 3/4	1772	25 1/2	648	342	155	776	352
164	119 3/8	3032	91 1/8	2314	117 7/8	2994	20 1/2	521	116 5/8	2962	85 1/4	2165	27 1/8	689	115 1/8	2934	87 3/4	2229	27 1/8	689	416	189	903	410

INSTALLATION INSTRUCTIONS

IMPORTANT THE FOLLOWING KEEPRITE REFRIGERATION CENTRIFUGAL FAN UNITS **MUST** BE
PLATFORM OR FLOOR MOUNTED
CONDENSERS KCC237, KCC141, KCC150, KCC164

GENERAL

Unit should be carefully checked for damage when received. Visible or concealed damage should be reported immediately to the carrier and a claim filed.

All KCC Centrifugal condensers are inspected thoroughly before shipment. However, fans and shaft should be inspected before installation to insure that misalignment has not happened in shipment or handling. For long and trouble free life, the units should have proper care and maintenance.

Units should be located so that enough space is left around the unit for lubrication, belt adjustment and coil removal if necessary.

For units with free air intake and discharge, care should be taken to insure that there are no obstructions that will interfere with the air flow.

DRIVE INSTALLATION

Smaller motors are usually shipped mounted on the unit. Larger motors will be shipped separately. When motors are shipped separately the mounting procedure should be as follows:

- (a) Bolt motor to the motor base on the unit.
- (b) If not already mounted, install fan motor sheaves.
- (c) Align sheaves with straight edge to insure true running belts.

- (d) Adjust motor mount for proper belt tension.
- (e) Attach belt guard to end panel of blower section.

MOUNTING UNITS

Smaller models may be floor mounted or ceiling hung. Larger models may be floor mounted only. When hoisting units, a spreader bar should be used to prevent damage to the casing. Units are equipped with 5/8 " (16 mm) N.C. tapped hanger nuts or 3/4 " (19 mm) anchor holes for floor mounting.

DUCTWORK

Where ductwork is to be used with units, connection to unit should be made with flexible canvas sleeves.

MAINTENANCE BEFORE START UP

- (a) Check tightness of all bearing, sheave and fan wheel set screws.
- (b) If fan wheel set screws are loose, check to insure that Wheel is not rubbing in housing.
- (c) Leak-test system to make sure that all joints are tight.
- (d) Ball bearings are pre-lubricated and require no further lubrication at start-up.
- (e) Rotate shaft by hand to make sure it runs freely.
- (f) Check fan and motor for correct rotation. If running the wrong direction, reverse phases at motor. Re-check rotation.
- (g) Check drive alignment and belt tension.

AFTER FIRST 48 HOURS

1. Check all previous points under "Before Start-Up".
2. Belts will have stretched. Re-check tension and adjust motor where necessary.

PERIODIC SERVICE & MAINTENANCE

- (a) Check all moving parts for wear every 6 months.
- (b) Check bearing collar set screws for tightness every 6 months.
- (c) Check belt tension and adjust if necessary.

MOTOR BEARINGS

All ball bearings are pre-lubricated and do not require any additional grease at time of installation. However, periodic cleaning out and renewal of grease is necessary. Please note extreme care must be taken to insure that foreign matter does not enter the bearing. It is also important to avoid over greasing. Only a high grade clean mineral grease should be used. Specific greasing instructions should be in accordance with the motor manufacturer's recommendations. Melting point of grease should not be under 150°C (302°F).

FAN BEARINGS

All ball bearings are pre-lubricated and do not require any additional lubrication at time of installation. However, periodic cleaning out and renewal of grease is necessary. Internal bearings are accessible through access

panel in cabinet. Units are equipped with extended lube lines and will have grease fittings for internal bearings on drive end panel of blower section. Apply grease when bearings are running, adding slowly until a slight bleeding of grease from the seals is noted. Access door should be removed so that internal bearing may be viewed when greasing.

DO NOT OVER LUBRICATE

The lubrication interval varies with the period of operation and temperature of the ambient air. The following interval is recommended:

Temperature Range	Time Interval
60 - 80°F (16 - 26°C)	2 years
81 - 100°F (27 - 37°C)	1 1/2 years
101 - 120°F (38 - 49°C)	1 year

For units which have been in operation for several years or where some bearing wear has occurred through adverse operating conditions, lubrication may be required as frequently as every 2 months.

ARMVAC 781 available from Standard Oil Company or Imperial Oil Company is the recommended lubricant for fan shaft bearings. Lubricant will be satisfactory down to -40°F (-40°C) ambient temperature.

REPLACEMENT PARTS

When replacement parts are required, furnish factory with Unit Model No. and Serial No. as shown on drive end of unit.

DESIGN SPECIFICATIONS

TYPE KCC CENTRIFUGAL FAN AIR COOLED CONDENSERS

CASING

Furnish and install where shown on the drawings, Centrifugal Fan Air Cooled Condenser(s) by KeepRite or approved equal. Sizes and performance shall be as indicated in the unit schedule. Cabinets shall be of sectionalized construction, and all sheet metal parts, including accessories, shall be of continuous galvanized sheet steel. Cabinet shall be angular steel frame construction with casing panels easily removable for access to the interior of the unit.

FANS

Fans shall be designed for class 1 operation. Fan ratings shall be based on fan tests conducted in accordance with AMCA Code No. 210. Fan housings and wheels shall be continuous galvanized steel. Fan wheels over 12 " (305mm) diameter shall be keyed to the fan shaft. The fan shaft shall be solid high carbon steel, fully sized throughout.

The maximum rate of fan RPM shall be well below the first critical fan shaft speed.

BEARINGS

Bearings shall be self-aligning, grease lubricated, ball type. All bearings shall be sized with a

minimum service factor of four. Extended lubrication lines with zerk type fittings shall be provided and permanently lubricated bearings will not be allowed.

COILS

Coils shall be constructed of rippled aluminum fins hydraulically bonded to copper tubing for permanent metal-to-metal contact and maximum heat transfer efficiency. Fins shall be die-formed with wide smooth collars to completely cover the tubing for optimum corrosion resistance. Coils shall be factory leak tested at 300 psi, dehydrated, sealed and braced to seamless copper headers. Any number of coil circuits shall be available provided the total does not exceed the number of tubes in the coil face. Coils shall be provided with sweat-type connections and shall be circuited for proper refrigerant drainage.

DRIVE

Units shall be provided with adjustable motor bases and adjustable drives so as to permit 10% adjustment in fan speed in either direction. Factory supplied and mounted motor electrical characteristics: 208, 230 or 575/3/60.

**DISCONTINUED
PRODUCT**

**DISCONTINUED
PRODUCT**

SERVICE LOG

DATE	COMMENTS

PROJECT INFORMATION

System	
Model Number	Date of Start-Up
Serial Number	Service Contractor
Refrigerant	Phone
Electrical Supply	Fax



NATIONAL REFRIGERATION &
AIR CONDITIONING CANADA CORP.



CANADA

159 ROY BLVD., BRANTFORD, ONTARIO, CANADA N3R 7K1
PHONE: 1-800-463-9517 (519)751-0444 FAX (519)753-1140

USA

985 WHEELER WAY, LANGHORNE, PA. 19047 USA
PHONE: 1-888-KEEPUS1 OR 1-888-533-7871