



KCH Air Cooled Condensers

PRODUCT DATA & INSTALLATION

Bulletin K50-KCH-PDI-10
1042027

We are on the Internet 
www.keepriterefrigeration.com

Refrigerants - R12, R22 and R502

Electrical Power: 208-230/1/60, 460/1/60
& 575/1/60

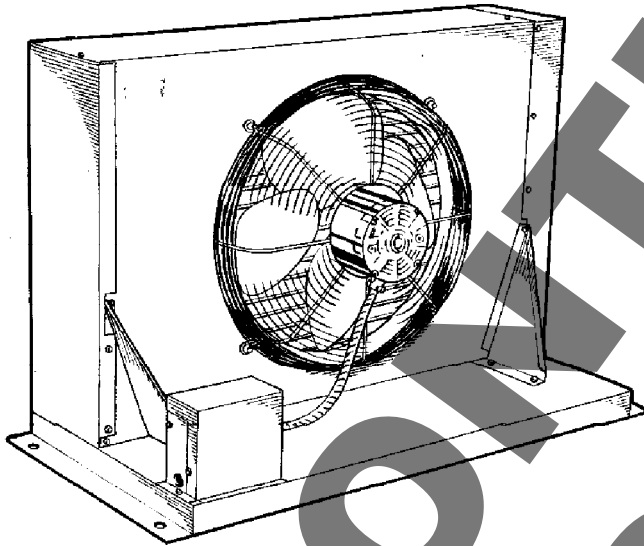

- CSA approved for outdoor and indoor applications
- Totally enclosed, ball bearing 1500 RPM, PSC High Efficiency Motors.
- Coils fabricated with 3/8 O.D. copper tube mechanically expanded to corrugated aluminum fins.
- Rugged heavy gauge galvanized steel construction.
- Vinyl coated fan grille and motor mount for improved appearance and durability.

NOMENCLATURE

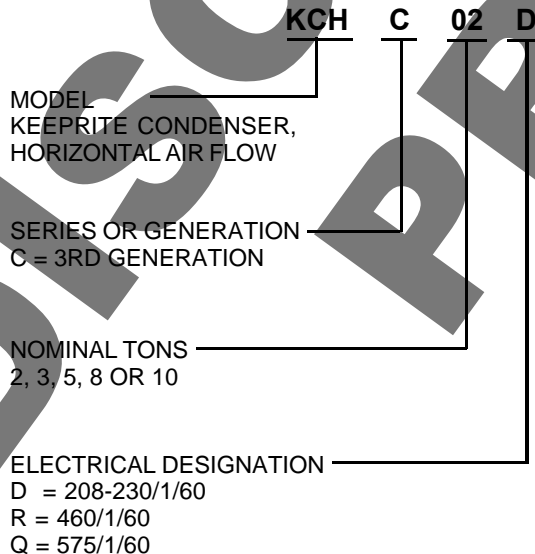

CONTENTS

PAGE

Nomenclature.....	Cover
Capacity Data.....	2
Electrical/Physical Data.....	2
Dimensional Data.....	2
Inspection.....	3
Location.....	3
Piping.....	3
Electrical.....	3
Wiring Diagram.....	3
Maintenance.....	3
Low Ambient Operation.....	Back
Service Parts List.....	Back

SPECIFICATIONS

* CAPACITY DATA - (TOTAL HEAT OF REJECTION - BTUH)

MODEL	T.D. - TEMPERATURE DIFFERENCE (COND. TEMP. - AMBIENT)				
	10° F	15° F	20° F	25° F	30° F
KCHC02D	10,500	15,750	21,000	26,250	31,500
KCHC03D	15,767	23,650	31,533	39,417	47,300
KCHC05D	25,633	38,450	51,267	64,083	76,900
KCHC08D	38,400	57,600	76,800	96,000	115,200
KCHC10D	50,833	76,250	101,667	127,083	152,500

* Above capacity using R22. For R12 multiply R22 capacity by X .95. For R502 multiply R22 capacity by X .98.

ELECTRICAL / PHYSICAL DATA

MODEL	ELECTRICAL POWER	MOTORS QTY-HP	FLA EACH	MIN. CIRC. AMPACITY	MAX.** FUSE (A)	FANS QTY-DIA.	AIR FLOW CFM	REFRIG. CHARGE R22 (lbs)	UNIT WEIGHT(lbs) (APPROX.)
KCHC02D	208/230-1-60	1-1/5	2.3	2.9	15	1-18"	3400	.83	140
KCHC03D	208/230-1-60	1-1/5	2.3	2.9	15	1-18"	3380	1.91	140
KCHC05D	208/230-1-60	1-1/5	2.3	2.9	15	1-18"	3250	3.34	200
KCHC08D	208/230-1-60	2-1/5	2.3	5.2	15	2-18"	6660	5.25	270
KCHC10D	208/230-1-60	2-1/5	2.3	5.2	15	2-18"	6420	6.74	350

** Dual element type fuse.

DIMENSIONAL DATA (INCHES)

KCHC02D - KCHC05D

KCHC08D & KCHC10D

MODEL	COND. WIDTH	COND. DEPTH	COND. HEIGHT	ELECT. CONN.	INLET (GAS) CONN.	OUTLET (LIQUID) CONN.
	A	B	C	D	E	F
KCHC02D	44 11/32	20 1/2	32 1/16	7/8	5/8	3/8
KCHC03D	44 11/32	20 1/2	32 1/16	7/8	5/8	5/8
KCHC05D	44 11/32	20 1/2	32 1/16	7/8	5/8	5/8
KCHC08D	65 11/32	20 1/2	38 1/16	7/8	7/8	7/8
KCHC10D	65 11/32	20 1/2	38 1/16	7/8	7/8	7/8

INSTALLATION INSTRUCTIONS

INSPECTION

Careful inspection of all parts when received for loss or damage in transit is very important - Remember, you, the consignee, must make any claim necessary against the transportation company. Shipping damage or missing parts, when discovered at the outset, will prevent later unnecessary and costly delays.

Electrical characteristics should also be checked at this time to ensure that they are as ordered.

LOCATION

KeepRite Refrigeration KCH Air Cooled Condensers are designed for outdoor installation. A number of factors must be taken into consideration when selecting a location. Most important is the provision for a supply of ambient air to the condenser, and removal of heated air from the condenser area. Failure to do so will result in higher condensing temperatures, decreased performance, plus the possibility of equipment failure.

Other considerations include:

1. Distance to suitable electrical supply.
2. Accessibility for maintenance.
3. Local building codes.
4. Adjacent building relative to noise levels.
5. Wishes of the purchaser.
6. Minimum of 2 ft. between units side by side and 4 ft. from wall (front & back).

REFRIGERANT PIPING

The importance of correct refrigerant pipe sizing and layout cannot be over-emphasized. Failure to observe proper refrigerant piping practices can result in equipment failure which may not be covered under warranty.

KeepRite Refrigeration Air Cooled Condensers are supplied complete with headers and refrigerant connections sized for connecting to standard refrigeration tubing.

Refer to the KeepRite Refrigeration Engineering Manual or other recognized sources of information for correct pipe sizing and installation.

ELECTRICAL

Wire system in accordance with governing standards and local codes. Electrical wiring is to be sized in accordance with minimum ampacity rating.

For ease of identifying the proper wiring terminals, unit wiring is color coded and terminal block connections are identified. Electrical connections are made at an external junction box.

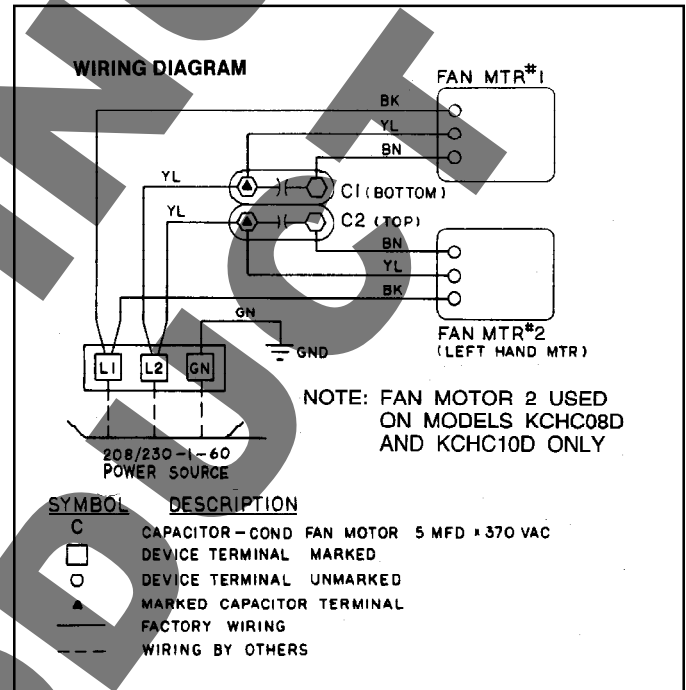

MAINTENANCE

A semi annual inspection should be carried out by a qualified refrigeration service mechanic. The main power supply must be disconnected.

1. Check electrical components. Tighten any loose connections.
2. Check tightness of all fans and motor mounts. Remove any deposits which could affect fan balance.
3. Clean the condenser coil using a soft brush or by flushing with cool water or commercially available coil cleaners.

LOW AMBIENT - WINTER OPERATION

When selecting a KeepRite Refrigeration "KCH" Air Cooled Condenser that will operate during the winter, some method of controlling the head pressure must be considered. At temperatures lower than 50 °F the condenser will be oversized, resulting in low head pressure. This in turn will cause poor expansion valve operation and unstable evaporator performance. This may result in unsatisfactory system performance and potential compressor failure. KeepRite Refrigeration recommends the "Flooded - Condenser" method of head pressure control.

Since additional liquid refrigerant is required, the system must be designed to allow enough refrigerant to fill the condenser as well as the receiver in order to maintain a liquid seal. The receiver must also be sized accordingly to contain this extra refrigerant during a pump-down or when operating at higher ambient conditions (summer). Depending on the actual low ambient temp (0 °F to -40 °F) and application (High, Med, Low) the flooded condenser pressure control will flood the condenser anywhere from 70 to 97% full of liquid.

TOTAL LIQUID CHARGE (100% FULL)* - (lbs)			
MODEL	R12	R22	R502
KCHC02D	6	5.6	5.8
KCHC03D	12	11.1	11.6
KCHC05D	23.9	22.3	23.1
KCHC08D	32.5	30.3	31.4
KCHC10D	43.3	40.3	41.8

* Based on temperatures (density) of refrigerant at 0 °F

To calculate the partially flooded refrigerant charge for specific ambient temps and application follow the recommended charging instructions supplied by the valve manufacturer.

SERVICE PARTS LIST

DESCRIPTION	PART NO.
FAN MOTOR - 208/230V 1/5 HP	1041300
CAPACITOR - 5 MFD - 370 V	171521-056
FAN BLADE - B1822-4	1042139
FAN GUARD/MOTOR MOUNT	1041313
TERMINAL BLOCK	1041289

DESCRIPTION	PART NO.
CONDENSER COIL (02)	1042441
CONDENSER COIL (03)	1042219
CONDENSER COIL (05)	1042148
CONDENSER COIL (08)	1042220
CONDENSER COIL (10)	1042221



NATIONAL REFRIGERATION & AIR CONDITIONING CANADA CORP.

159 ROY BLVD., BRANTFORD, ONTARIO, CANADA N3T 5Y6
PHONE: 1-800-463-9517 (519)751-0444 FAX (519)753-1140

