



PRODUCT DATA & INSTALLATION

Bulletin K60-KDF-PDI-10

1064436

We are on the Internet 
www.keepriterefrigeration.com

KDF Direct Drive Dry Type Fluid Coolers

Air Cooled Models from 200 MBH to 2,000 MBH

One to Six fan Units Glycol Selection Data

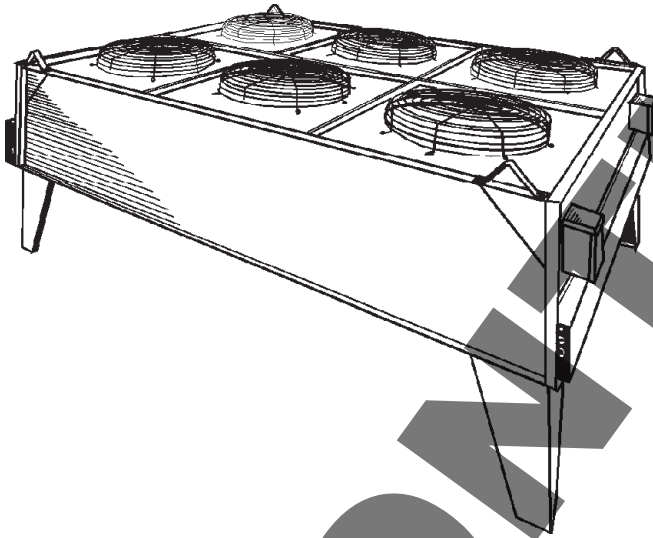

- Heavy gauge galvanized steel casing with zinc plated nuts and bolts
- Die-formed legs
- High efficiency coils with rippled aluminum fins hydraulically bonded to copper tubing.
- Four-bladed heavy gauge rust resistant aluminum fans with steel spider and hub.
- Direct drive fan motors with inherent overload protection.
- Motors are weather protected by top end rain shields and shaft moisture slingers.

NOMENCLATURE

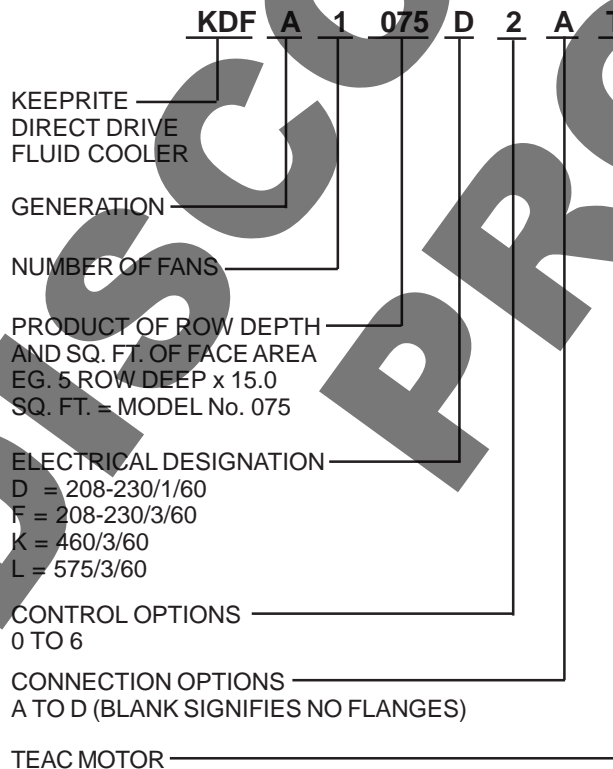

CONTENTS

PAGE

Nomenclature.....	Cover
Capacity Data.....	2
Selection Data Notes.....	2
Sample Selection.....	3, 4, 5
Dimensional Data.....	6
Installation Instructions.....	7, 8
Design Specifications.....	Back
Service Log.....	Back
Project Information.....	Back

CAPACITY DATA

M.B.H. / SQ. FT. COIL FACE AREA

Table 1

Approach		INITIAL TEMPERATURE DIFFERENCE (I.T.D.)																	
°F	°C	20°F (11°C)	25°F (14°C)	30°F (17°C)	35°F (19°C)	40°F (22°C)	45°F (25°C)	50°F (28°C)	55°F (30°C)	60°F (33°C)	65°F (36°C)	70°F (39°C)	75°F (42°C)	80°F (44°C)	85°F (47°C)	90°F (50°C)	95°F (53°C)	100°F (55°C)	
5	3	4.9	5.7	6.6	7.5	8.1	8.8	9.5	10.2	10.9	11.6	12.3	13.1	13.9	14.5	15.2	15.9	16.7	
10	6	6.1	7.0	8.0	8.9	9.9	10.8	11.7	12.5	13.3	14.1	15.0	15.7	16.4	17.2	18.1	18.8	19.6	
15	8		8.0	9.1	10.0	11.2	12.1	13.1	14.0	14.9	15.7	16.6	17.5	18.5	19.3	20.2	20.9	21.7	
20	11			9.9	11.0	12.1	13.1	14.1	15.1	16.2	17.2	18.3	19.1	20.0	20.8	21.8	22.6	23.5	
25	14				11.7	13.0	14.0	15.0	16.2	17.4	18.4	19.4	20.4	21.4	22.9	23.3	24.1	25.0	
30	17					13.7	14.8	16.0	17.2	18.4	19.4	20.5	21.5	22.7	23.5	24.5	25.4	26.4	
35	19						15.5	16.7	17.9	19.2	20.3	21.5	22.6	23.7	24.7	25.6	26.6	27.5	
40	22							17.5	18.7	20.0	21.2	22.4	23.5	24.6	25.6	26.6	27.7	28.5	
45	25								19.3	20.6	21.9	23.2	24.3	25.4	26.5	27.6	28.6	29.5	
50	28									21.2	22.5	23.9	25.0	26.2	27.3	28.5	29.5	30.5	
55	30										23.2	24.5	25.7	27.0	28.1	29.3	30.4	31.4	
60	33											25.0	26.2	27.5	28.7	30.0	31.1	32.3	
65	36												27.0	28.1	29.4	30.7	31.8	33.0	
70	39													28.7	30.0	31.4	32.5	33.7	
75	42														30.7	32.0	33.2	34.4	
80	44															32.6	33.9	35.1	
85	47																34.6	35.8	
90	50																	36.5	

COIL FACE AREA

Table 1A

Model KDF		1052	1060	2100	2120	3152	3180	4200	4240	6300	6360
Coil Face Area	Sq. Ft.	12.5	15.0	25.0	30.0	37.5	45.0	50.0	60.0	75.0	90.0
	m ²	1.16	1.39	2.32	2.79	3.48	4.18	4.65	5.57	6.97	9.36
Fan Data	No.	1	1	2	2	3	3	4	4	6	6
	Total CFM	7050	7380	14100	14760	21150	22140	28200	29520	42300	44280
	Total m ³ /s	3.33	3.48	6.65	6.97	9.98	10.45	13.31	13.93	19.96	20.9

Data shown covers 10 models, 10 additional models available. Consult your local KeepRite Refrigeration Sales Office.

1. Temperature Limitations

KeepRite fluid coolers are suitable for leaving air temperatures up to a maximum of 130°F (54°C). Fluid temperature up to an average of 150°F (66°C) may be used at ambient temperatures up to 90°F (32°C). Entering fluid conditions should however not exceed 200°F (93°C).

2. Elevation Adjustment

Capacities are suitable for elevations up to 2000 ft. Above 2000 ft. and up to 3000 ft. elevation, unit capacities shown in Table 1 must be corrected by .90 before selecting unit.

3. Ratings

Ratings are based on a standard heat transfer rate and fluid velocity is varied to suit. Ratings and selections will be conservative. For additional fluid cooler models and more detailed analysis and selections, the KeepRite fluid cooler computer

selection programme is available. Interpolation of capacities shown in Table 1 is permitted. Do not extrapolate.

4. Fluid Velocities

Fluid velocities are adjusted in accordance with the average temperature and the glycol mixtures used. Where a selected unit has a coil face area larger or smaller than the actual size required, the basic fluid velocity must be adjusted (see example).

5. Low Flow Rates

Where flow rate is low (approx. 10 USGPM or lower), standard circuiting may not provide the necessary tube velocity. Contact Head Office for special circuiting.

6. KeepRite selection sheets are available for assisting in the selection and recording of data. Contact your local KeepRite Sales Office for copies.

SAMPLE SELECTION

Example

Required:

A computer room application requires a KDF fluid cooler to handle a load of 50 USGPM of 50% Ethylene Glycol. (By wt.) from 115°F (46°C) to 105°F (40°C) at 95°F (35°C) Ambient. Unit located at sea level.

Selection Method

(1) **Find the Total BTU/hr. Requirements (Q)**
 BTU/hr. = USGPM x fluid T.D. x Factor "N" (Table 2)
 = 50 x 10 x 434
 = 217,000 BTU/hr. (63 kw)

(2) **Find minimum CFM required**

$$CFM = \frac{(Q) \text{ BTU/hr}}{1.09 \times (130^\circ\text{F} - \text{Amb. Temp. } ^\circ\text{F})}$$

$$= \frac{217,000}{1.09 \times 35} = 5688 \text{ CFM}$$

(3) **Find initial temperature difference and approach**
 I.T.D.: = Ent, fluid temperature minus entering ambient air temperature
 = 115° - 95°F
 = 20°F (11°C)

Approach: = Leaving fluid temperature minus entering ambient temperature
 = 105° - 95°F
 = 10°F (6°C)

(4) **Find MBH Capacity per sq. foot of fluid cooler surface**
 For an ITD of 20°F (11°C) and an approach of 10°F (6°C) read from Table 1 a unit capacity of 6.1 MBH/sq. ft. of coil surface area. As this application is at sea level no correction is necessary.

(5) **Determine total area of coil surface required**
 Coil surface, sq. ft.
 = $\frac{\text{Total BTU/hr. (Q) (Step 1)}}{\text{MBH/sq. ft. (Step 4) x 1000}}$
 = $\frac{217,000}{6100}$
 = 35.6 sq. ft.

(6) **Select Unit**
 From Table 1A select a unit size having a coil face area equal to or larger than 35.6 sq. ft. A Model 3152 has a face area of 37.5 sq. ft. This selection would be suitable.

(7) **Check air quantity**
 A Model 3152 is rated at 21150 CFM. This exceeds the minimum of 5688 CFM (step 2) and is satisfactory. (See Table 1A for CFM capacities).

(8) **Determine minimum fluid velocity required**
 From Table 3 for a 50% glycol solution at an average temperature of 110°F (43°C), the required basic velocity is 3.1 ft./second.

(NOTE. When unit selected has a face area larger or smaller than that required in step (5), basic fluid velocity should be adjusted using velocity correction factor from Table 4.

For this example, the required coil face area is 35.6 sq. ft. (5 above). Actual coil face area is 37.5 sq. ft.

$$\text{Ratio oversize} = \frac{37.5}{35.6} = 1.05$$

From Table 4 the velocity correction factor is .95. This is applied to the basic velocity to obtain the required minimum velocity:
 .95 x 3.1 = 2.9 ft./sec.

(9) **Circuiting requirements**
 Refer to Chart 1 at 50 G.P.M., Type.30 circuiting will provide a velocity of 2.83 ft./sec. This is close to the required minimum velocity of 2.9 ft./sec, and may be used. (See note 2 Chart 1 for minimum velocity range).

(10) **Determining Fluid Pressure Drop**
 Knowing the circuiting to be used, the fluid pressure drop can be determined as follows:

(a) Find the Total Equivalent Length of tube circuit from Table 5. For a model KDF 3152, using type 30 circuiting, the T.E.L. is 51 feet.

(b) From Table 6, note the pressure drop under 50% solution at 2.9 ft./sec. as 060 P.S. 1. per foot of equivalent length.

(c) Total pressure drop, P.S.I. = Pressure drop per foot (b) multiplied by 51 feet T.E.L. (a) plus standard allowance of 2 P.S. I. for headers:
 .060 x 51 = 3.06 P. S. I.
 Headers = 2.00 P. S. I.
 5.06 P. S. I.

Apply temperature correction factor from Table 7
 = .97 x 5.06 = 4.90 P. S. I.

(11) **Final Selection**
 1 - KeepRite KDF fluid cooler model 3152 using type 30 circuiting, having a fluid pressure drop of 4.90 P.S.I. connections will be same end (Table 5).

Headers and connection sizes will be 2 1/8" O.D. (Table 8).

"N" FACTORS

Table 2

AVE. FLUID TEMP.	FACTOR "N"			
	% GLYCOL SOLUTION			
	30%	40%	50%	60%
50	466	437	420	394
70	467	442	426	400
100	469	446	432	408
120	470	448	436	411
130	470	450	438	414
140	470	452	439	416
150	470	452	440	418

TUBE CIRCUITING

Chart 1

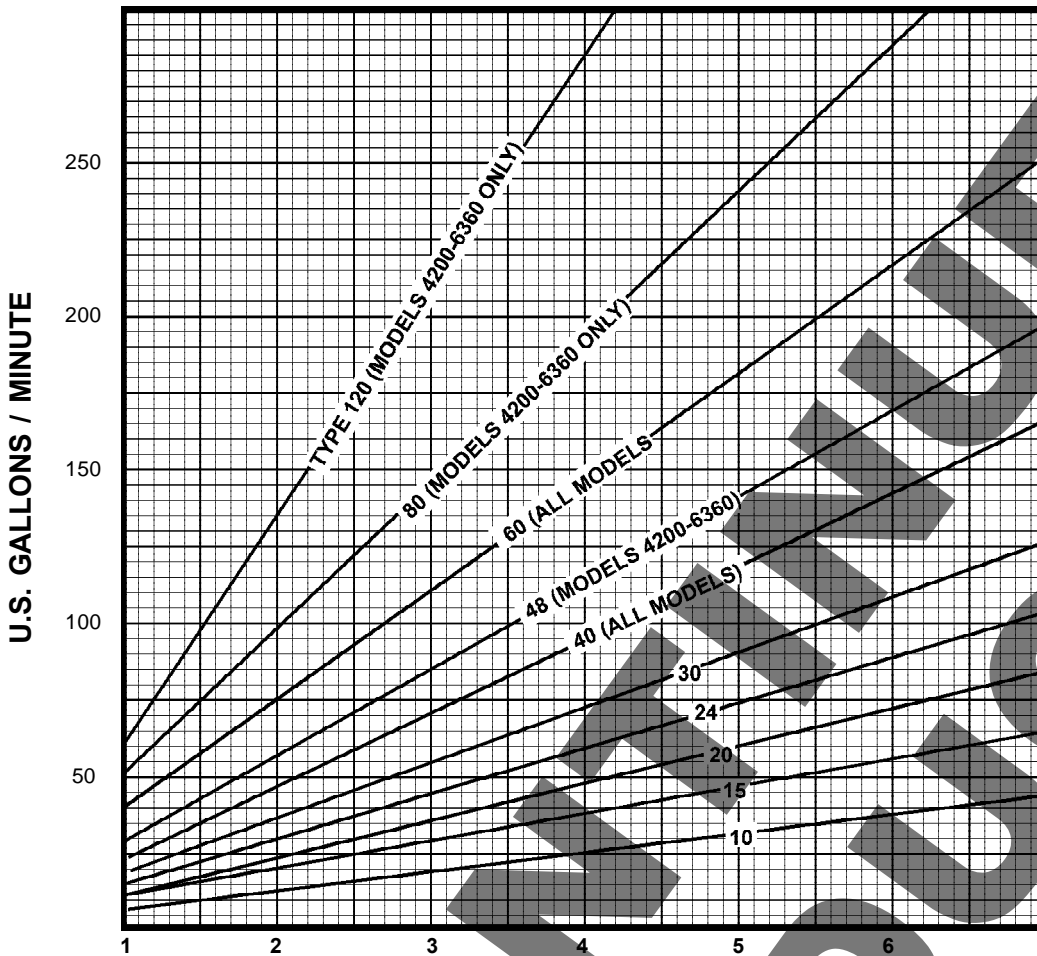

- NOTES: 1. For more accurate readings use the following formula

$$\text{Fluid VEL Ft./sec.} = \frac{\text{GPM} \times 1.70}{\text{Circuit Type}}$$
2. When selecting circuiting, the velocity obtained can be lower than the desired velocity by not more than 5%. A greater difference will require an alternate circuit type to be selected. Velocities higher than the desired velocity are acceptable.

BASIC FLUID VELOCITY

Table 3

AV. FLUID TEMP°	GLYCOL SOLUTION %			
	30	40	50	60
50	2.9	3.7	4.6	5.8
70	2.5	3.1	3.9	5.0
100	2.0	2.6	3.2	4.2
110	2.0	2.5	3.1	4.0
120	2.0	2.4	3.0	3.8
130	2.0	2.3	2.8	3.6
140	2.0	2.2	2.7	3.4
150	2.0	2.0	2.6	3.3

Table 4

COIL AREA RATIO	VEL.* CORR. FACTOR
.85	1.30
.90	1.20
.95	1.10
1.00	1.00
1.10	.90
1.20	.80
1.30 and over	.70

* When VEL correction factor is applied to basic fluid velocity maximum velocity should not exceed 6 ft./sec. Minimum should not exceed 2 ft./sec.

LENGTH OF TUBE CIRCUIT

Table 5

Circuit	Header Location	EQUIVALENT LENGTH OF TUBE CIRCUIT																			
		1052		1060		2100		2120		3152		3180		4200		4240		6300		6360	
		FT.	M	FT.	M	FT.	M	FT.	M	FT.	M	FT.	M	FT.	M	FT.	M	FT.	M	FT.	M
120	SE	NA	NA	NA	NA	NA	NA	NA	NA	NA	NA	NA	NA	20	6.10	23	7.02	27	8.24	31	9.46
80	OE	NA	NA	NA	NA	NA	NA	NA	NA	NA	NA	NA	NA	29	8.85	33	10.07	39	11.90	44	13.42
60	SE	14	4.27	15	4.58	20	6.10	23	7.02	27	8.24	31	9.46	38	11.59	42	12.81	51	15.56	58	17.69
48	OE	NA	NA	NA	NA	NA	NA	NA	NA	NA	NA	NA	NA	46	14.03	52	15.86	63	19.22	72	21.96
40	†	19	5.80	21	6.41	29	8.85	33	10.07	39	11.90	44	13.42	55	16.78	62	18.91	75	22.88	86	26.23
30	SE	24	7.32	27	8.24	38	11.59	42	12.81	51	15.56	58	17.69	72	21.96	82	25.01	99	30.20	113	34.47
24	†	30	9.15	33	10.07	46	14.03	52	15.86	63	19.22	72	21.96	90	27.45	101	30.81	123	37.52	141	43.01
20	SE	37	11.29	39	11.90	55	16.78	62	18.91	75	22.88	86	26.23	107	32.64	121	36.91	147	44.84	168	51.24
15	SE	46	14.03	50	15.25	72	21.96	82	25.01	99	30.20	113	34.47	142	43.31	160	48.80	195	59.48	223	68.02
10	SE	67	20.44	74	22.57	107	32.64	121	36.91	147	44.84	168	51.24	211	64.36	239	72.90	291	88.76	333	101.57
5	SE	131	39.95	145	44.23	211	64.36	239	72.90	291	88.76	333	101.57	419	127.80	475	144.88	579	176.60	663	202.22

† 1052-3180 - Opposite End 4200-6360 - Same End

TUBE PRESSURE LOSS**

Table 6

FLUID VEL. F/S	PRESS. LOSS PSI/FT. T.E.L.			
	30%	40%	50%	60%
2.0	.028	.029	.032	.034
2.2	.036	.050	.041	.044
2.5	.042	.044	.048	.051
2.7	.048	.050	.055	.059
3.0	.055	.058	.063	.067
3.2	.064	.069	.074	.079
3.5	.072	.077	.083	.089
3.7	.080	.085	.092	.098
4.0	.090	.097	.104	.111
4.2	.100	.107	.115	.123
4.5	.110	.117	.126	.135
4.7	.122	.130	.140	.150
5.0	.140	.149	.161	.172
5.2	.164	.175	.189	.202
5.5	.183	.195	.210	.225
5.7	.207	.221	.238	.255
6.0	.231	.247	.266	.285

Where to Use Direct Drive Fluid Coolers COMPUTER COOLING SECONDARY HEAT EXCHANGERS

The KeepRite direct drive cooler is suitable for use with computer room process cooling units. (See Fig. 1).

Particularly suitable for applications where long runs of refrigerant piping to an air cooled condenser are not practical. Eliminates the maintenance required with cooling towers and problems of winter operation. Piping can be easily installed and low ambient control can be obtained by using water regulating valves. Can be easily connected to city water for emergency use.

REMOTE RADIATORS FOR DIESEL AND GAS ENGINES

A remote radiator is usually required with the larger style of diesel or gas engine. The KeepRite K.D.F. direct drive cooler is suitable for this type of application. Designed to give the customer trouble free operation, the multiple fan arrangement reduces the possibility of down time. Units are completely pre-assembled and require only piping and electrical connections. Flexible circuiting permits low fluid pressure drop characteristics. (See Figure 2.)

INDUSTRIAL WATER COOLING*

The problem of water conservation and pollution has become critical in recent years. The "Once-only" use of water for industrial cooling purposes has been wasteful and often unnecessary. By using a KeepRite dry type cooler, water for industrial cooling applications can be cooled to within 10°F (6°C) of the ambient dry bulb temperature. The water is continuously recirculated and remains in a closed system so reducing the corrosion problem normally encountered in non recirculated systems. (See Fig. 3)

Considerable savings can be affected by using a KeepRite dry type cooler. Many industries have reduced water consumption by millions of gallons and reduced maintenance costs to a fraction of that experienced prior to using a closed recirculation system.

*For water cooling consult your local KeepRite sales office.

PRESSURE DROP TEMPERATURE CORRECTION FACTORS

Table 7

GLYCOL SOLUTION	AVG. FLUID TEMP. °F.							
	50	70	100	110	120	130	140	150
30%	1.25	1.00	.87	.84	.82	.79	.77	.74
40%	1.27	1.10	.93	.90	.87	.84	.82	.79
50%	1.30	1.20	1.00	.97	.94	.90	.88	.85
60%	1.40	1.25	1.09	1.05	1.01	.97	.94	.90

** Based on Ave. Fluid Temp of 100°F. Apply correction factor from table 7.

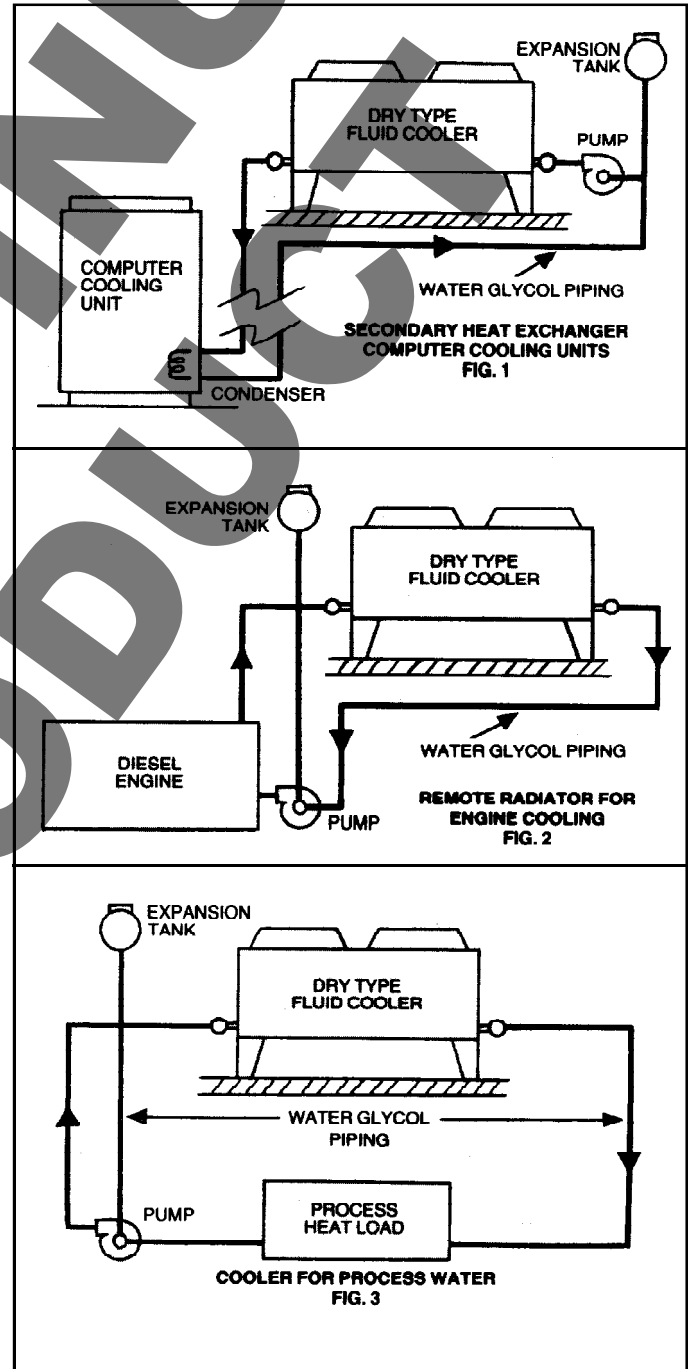

DIMENSIONS DATA

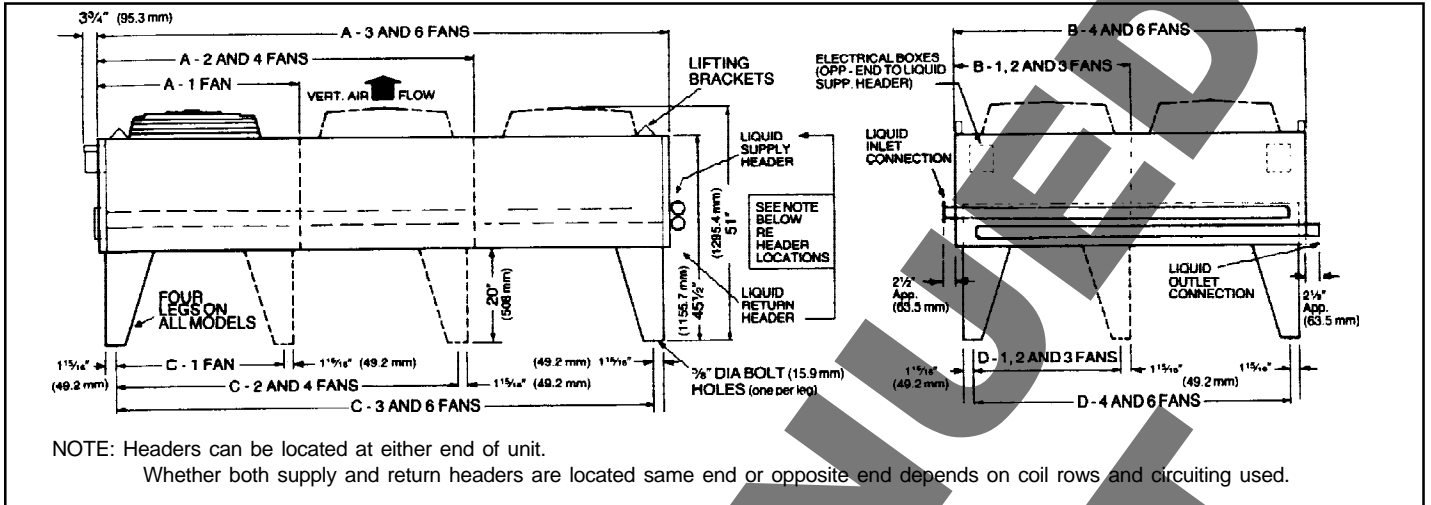

KDF MODEL No.	A		B		C		D		INTERNAL VOLUME		NUMBER OF FACE TUBE ROWS	FAN DATA			SHIPPING WEIGHT	
	Inches	mm	Inches	mm	Inches	mm	Inches	mm	U.S. * GALLONS WATER	LITRES*		No.	TOTAL CFM	TOTAL M ³ /S	Pounds	kg
1039	43	1092	48 1/8	1222	36	914	41 1/8	1045	3 1/2	13.3	30	1	7370	3.48	320	145
1052	43	1092	48 1/8	1222	36	914	41 1/8	1045	4 1/2	17.0	30	1	7050	3.33	355	161
1060	50	1270	48 1/8	1222	43	1092	41 1/8	1045	5 1/2	20.8	30	1	7380	3.48	390	177
1075	50	1270	48 1/8	1222	43	1092	41 1/8	1045	6 1/2	24.6	30	1	7150	3.37	430	195
2075	83 1/8	2111	48 1/8	1222	76 1/8	1934	41 1/8	1045	6	22.7	30	2	14740	6.96	580	263
2100	83 1/8	2111	48 1/8	1222	76 1/8	1934	41 1/8	1045	8	30.3	30	2	14100	6.65	645	293
2120	97 1/8	2467	48 1/8	1222	90 1/8	2289	41 1/8	1045	10	37.9	30	2	14760	6.97	725	329
2150	97 1/8	2467	48 1/8	1222	90 1/8	2289	41 1/8	1045	12	45.4	30	2	14300	6.75	800	363
3114	123 1/4	3131	48 1/8	1222	116 1/4	2953	41 1/8	1045	9	34.0	30	3	22110	10.43	870	395
3152	123 1/4	3131	48 1/8	1222	116 1/4	2953	41 1/8	1045	12	45.4	30	3	21150	9.98	965	438
3180	144 1/4	3664	48 1/8	1222	137 1/4	3483	41 1/8	1045	14 1/2	54.9	30	3	22140	10.45	1080	490
3225	144 1/4	3664	48 1/8	1222	137 1/4	3483	41 1/8	1045	18	68.1	30	3	21450	10.12	1200	544
4150	83 1/8	2111	93 1/8	2365	76 1/8	1934	86 1/8	2188	12 1/2	47.3	60	4	29480	13.91	1075	488
4200	83 1/8	2111	93 1/8	2365	76 1/8	1934	86 1/8	2188	16 1/2	62.3	60	4	28200	13.31	1200	544
4240	97 1/8	2467	93 1/8	2365	90 1/8	2289	86 1/8	2188	19 1/2	73.8	60	4	29520	13.93	1340	608
4300	97 1/8	2467	93 1/8	2365	90 1/8	2289	86 1/8	2188	24	91.0	60	4	28600	13.5	1500	680
6225	123 1/4	3131	93 1/8	2365	116 1/4	2953	86 1/8	2188	18	68.1	60	6	44220	20.87	1600	726
6300	123 1/4	3131	93 1/8	2365	116 1/4	2953	86 1/8	2188	24	91.0	60	6	42300	19.96	1850	839
6360	144 1/4	3664	93 1/8	2365	137 1/4	3483	86 1/8	2188	29	109.8	60	6	44280	20.9	2000	907
6450	144 1/4	3664	93 1/8	2365	137 1/4	3483	86 1/8	2188	36	136.3	60	6	42900	20.25	2200	998

* Headers not included. Motors are available for 208-230/1/60 - 1 HP, 208-230/3/60 - 1 1/3 HP, 575/3/60 - 1 1/4 HP.

Contact KeepRite Refrigeration for special requirements

NOTE: Metric figures are approximate to avoid excessive decimals.

OPTIONAL FACTORY SUPPLIED FLANGES				
SIZE (mm)	FITTING	FLANGE DIA. (mm)	BOLT CIRCLE (mm)	HOLES (mm)
3" (76.2)	Flanged	7 1/2" (190.5)	6" (152.4)	4-3/4" (19.05)
4" (101.6)	Flanged	9" (228.6)	7 1/2" (190.5)	8-3/4" (19.05)
5" (127.0)	Flanged	10" (254.0)	8 1/2" (215.9)	8-7/8" (22.2)
6" (152.4)	Flanged	11" (279.4)	9 1/2" (241.3)	8-7/8" (22.2)

OPTIONAL FLANGED CONNECTIONS

BOLT HOLE LOCATION

(150 lbs. working shock pressure)



INSTALLATION INSTRUCTIONS

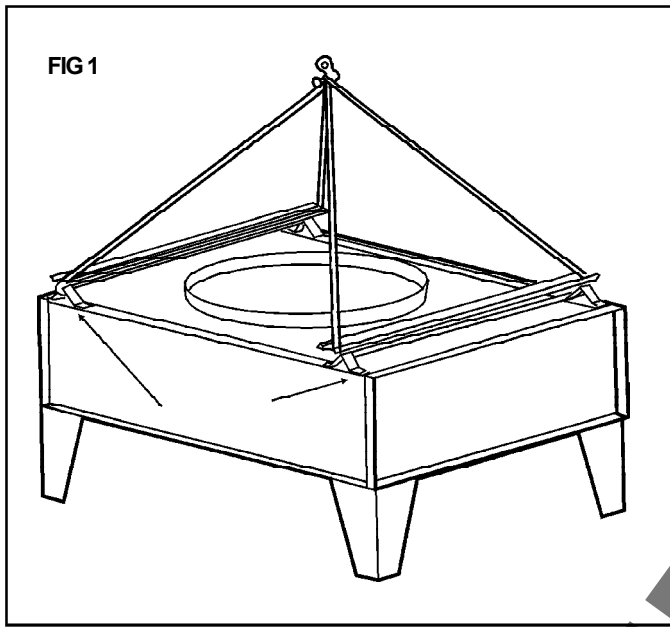

FIG 1

INSPECTION

A thorough inspection of the cooler and all component parts should be made immediately on delivery and any damage in transit or any missing parts must be reported at once to the carrier. As consignee, you must make any claim for damage or losses. Damaged or missing parts discovered at the outset can prevent later costly delays and unnecessary expense. Electrical characteristics of all motors should also be checked to ensure that they are as ordered.

WARNING

ADEQUATE PRECAUTIONS MUST BE TAKEN, AFTER FIELD LEAK TESTING, TO INSURE REMOVAL OF WATER IN TUBES. KEEPRIE RECOMMEND THAT A GLYCOL SOLUTION BE USED TO FLUSH THE COMPLETE COIL. FAILURE TO TAKE PRECAUTIONS CAN RESULT IN FROZEN TUBES SHOULD UNIT BE SUBJECTED TO LOW AMBIENT CONDITIONS BEFORE BEING PLACED IN OPERATION.

HANDLING AND PLACING

Air Cooled Fluid Coolers are by necessity large and heavy pieces of mechanical equipment and must be handled as such. A fully qualified and properly equipped crew with necessary tackle and rigging should be engaged to locate the unit in position.

Lifting brackets have been provided at the corners for attaching lifting slings. Spreader bars or a similar device must be used when lifting so that the lifting force will be applied vertically on the lifting brackets. (See Fig. 1).

LOCATION

In selecting a location for the cooler, consideration should be given to the following:

- (a) Loading capacity of the floor or roof.
- (b) Distance to suitable electrical supply.
- (c) Adequate air circulation.
- (d) Accessibility for maintenance.
- (e) Local building codes.
- (f) Adjacent buildings relative to noise levels.
- (g) Wishes of the purchaser.

When all of the above points have been considered and a specific location chosen, it is advisable to obtain written approval of this location from the building and/or cooling unit owner. This may be the means of avoiding disagreement and expense at a later date.

GENERAL CHECK-UP BEFORE STARTING

- (1) Check the electrical characteristics of all components to be sure they agree with the power supply.
- (2) Check fans for correct rotation on 3 phase units. Air is drawn through the cooler core. To change direction of rotation reverse any two (2) connecting leads.

Important:

Units with solid state speed control option are for use with 208-230/1/60 service only.

SERVICE INSTRUCTION

Casing

Since the Fluid Cooler is normally installed outdoors, in the elements, the casing is fabricated from heavy gauge continuous process galvanized sheet steel for maximum rust and corrosion protection.

Motors

Motors are split capacitor type and are permanently lubricated.

Coil

The coil should be checked periodically for cleanliness and for leaks. It is important that the coil be kept clean and free from any type of air blockage. The coil may be washed down with a hose when dirty. Power must be disconnected for this operation.

HEADER SIZING

Table 8

G.P.M.	Header Size O.D.	Connections Available
0 - 10	1 1/8 (29mm)	PLAIN or MPT
11 - 20	1 3/8 (35mm)	
21 - 30	1 5/8 (41mm)	
31 - 50	2 1/8 (54mm)	
51 - 80	2 5/8 (67mm)	
81 - 150	3 1/8 (79mm)	PLAIN or FLANGED
151 - 250	4 1/8 (105mm)	
251 - 400	5 1/8 (130mm)	
400 - 700	6 1/8 (156mm)	

PIPING INSTALLATION

1. All piping must comply with local codes. Care should be taken to correctly size the piping to ensure minimum pumping costs.
2. Sufficient valves and unions should be provided to permit easy removal of equipment for repair or replacement.
3. All piping should be leak tested after installation.
4. Where city water is required for make-up, local plumbing codes should be observed. A pressure reducing valve should not be used in glycol systems. Installation of same would dilute the mixture in the case of a leak.
5. Piping system must be complete with an expansion tank, purge valve, relief valve and fill point for glycol. Vent valves should be provided at system high points for air removal. See fig. 2 for typical glycol system piping.

CIRCULATING PUMP

Mechanical seal type circulating pumps are generally used for glycol systems. Pump must be selected for friction loss through the cooler, piping and heat source. In a closed system no allowance is required for vertical lift.

Parallel pumps are recommended for standby operation where pump failure may interfere with a critical process. One pump on a parallel system may also carry the load under certain conditions thus contributing to power economy.

GLYCOL DESIGN

Usually a glycol solution is used in fluid cooler applications. The common range of mixtures will be 30% to 50% in water. Glycol mixtures have a higher density than water, but a lower specific heat. This will result in an increased flow rate over water by approx. 15% - 20%. Where a fluid cooler is used with an existing water cooled condenser, a decrease in condenser capacity will result. Condenser manufacturers should be consulted to obtain recommended flow rates.

MAINTAINING THE SYSTEM

As the system is the closed type with a compression tank, little or no corrosion will take place as the initial oxygen is absorbed. No fresh oxygen is introduced unless the system requires re-filling due to leaks or repairs. Maintenance of the system will therefore be confined to the pumps and valves. Manufacturers data should be consulted for the maintenance of these items.

TYPICAL FLUID COOLER PIPING SYSTEM

Figure 2

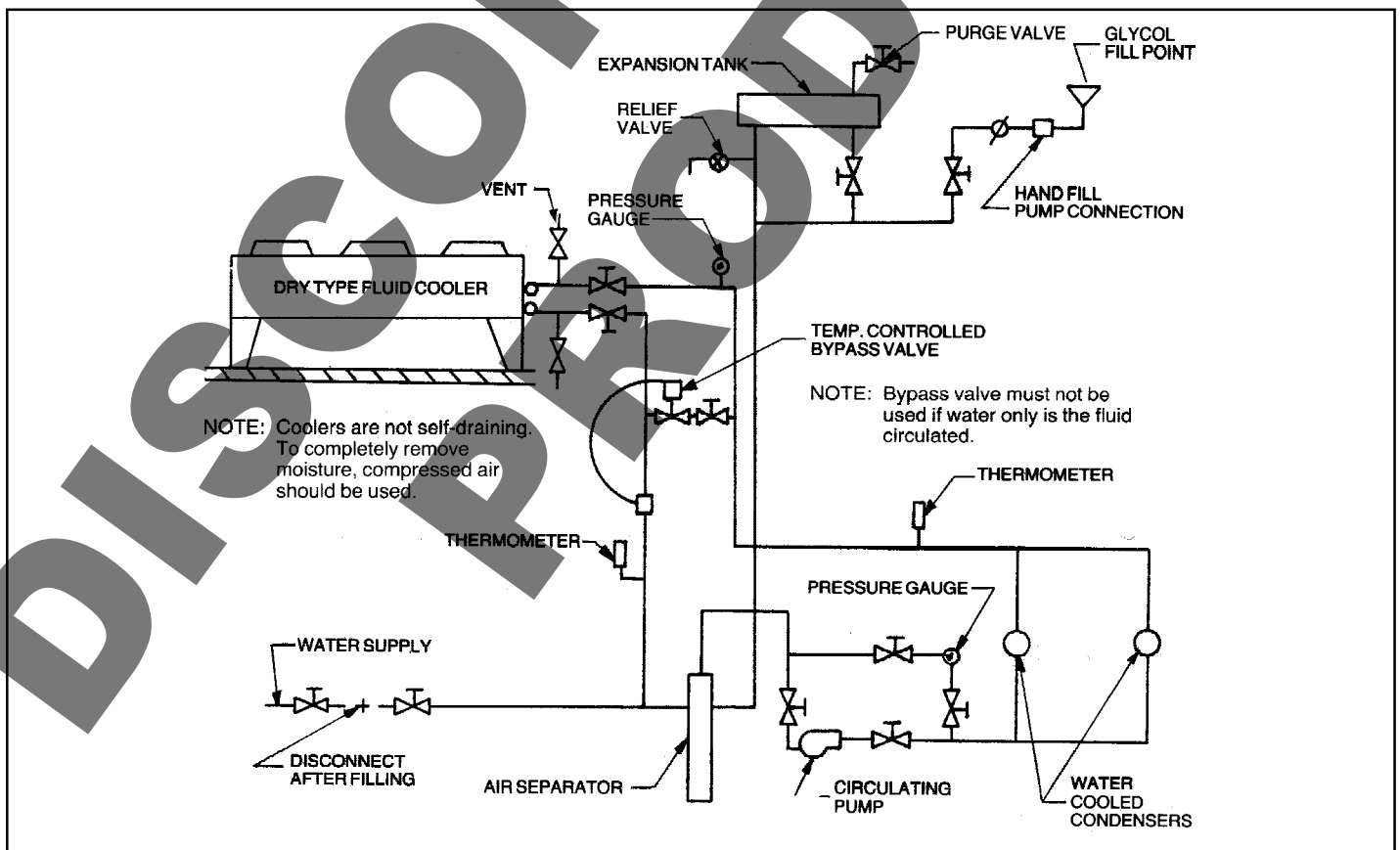

**DISCONTINUED
PRODUCT**

**DISCONTINUED
PRODUCT**

**DISCONTINUED
PRODUCT**

DESIGN SPECIFICATIONS

CASING

Heavy gauge galvanized steel with zinc plated nuts and bolts. All KeepRite Fluid Coolers are mounted on heavy die-formed legs.

COILS

The KeepRite Direct Drive Fluid Cooler is equipped with high-efficiency heat transfer surface. Surface consists of rippled aluminum fins hydraulically bonded to copper tubing. Coils are leak tested to 300 p.s.i. under water. Flanged connections available if required.

FANS

Four-bladed, constructed from heavy gauge, rust-resistant aluminum with steel spider and hub. Zinc plated for added weather protection.

MOTORS

Direct drive fan motors with permanently lubricated ball bearings. Motors are complete with inherent overload protection. Motors are weather protected by top end rain shields and shaft moisture slingers. Contactors available if required. Motors are all wired to an electrical box on end of unit.

SERVICE LOG

DATE	COMMENTS

PROJECT INFORMATION

System	
Model Number	Date of Start-Up
Serial Number	Service Contractor
Refrigerant	Phone
Electrical Supply	Fax



NATIONAL REFRIGERATION &
AIR CONDITIONING CANADA CORP.



CANADA

159 ROY BLVD., BRANTFORD, ONTARIO, CANADA N3R 7K1
PHONE: 1-800-463-9517 (519)751-0444 FAX (519)753-1140

USA

985 WHEELER WAY, LANGHORNE, PA. 19047 USA
PHONE: 1-888-KEEPUS1 OR 1-888-533-7871