



PRODUCT DATA & INSTALLATION

Bulletin K30-JUCE-PDI-14

1048678

We are on the Internet 
www.keepriterefrigeration.com

Electric Defrost Medium Profile JUC Unit Coolers 60 Hz

**Medium and Low Temp Applications
(-30°F Room Temp. or Higher)
Electrical Power: Three Phase**

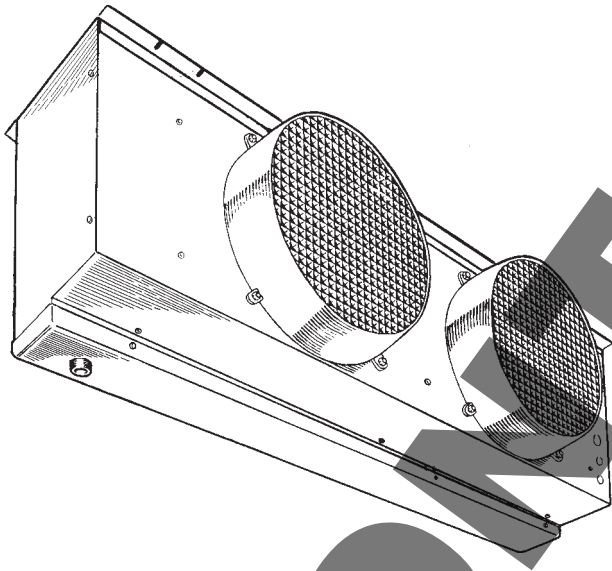

- * Heavy gauge textured aluminum cabinet construction resists scratches/corrosion and minimizes weight for shipment, installation and service.
- * Attractive and durable high density polyethylene fan guards with built-in throw boosters.
- * 3/8 Tubing coil construction (reduces operating charge).
- * VENTURI-FLO Distributor eliminates need for distributor nozzle selections.
- * Adjustable Defrost Termination Thermostat with dual Fan Delay function.
- * Stainless-Steel Defrost Heaters mounted on the face of coil for service accessibility

NOMENCLATURE

JUC C 1 29 E Z

KEEPRITE JUMBO UNIT COOLER

UNIT SERIES
C = 3RD GENERATION

NUMBER OF FANS

MBH CAPACITY @ 25 °F S.S.T.
10°F TD (60Hz)
29 = 29,000 BTUH

TYPE OF DEFROST
E = ELECTRIC DEFROST

ELECTRICAL DESIGNATION
Z = 208-230/3/60
J = 380/3/60
Y = 460/3/60
L = 575/3/60

- * Refrigerants R12, R22, R502, R134a, R404A, R407A, R407B, R407C, R507.

CONTENTS

	PAGE
Nomenclature.....	Cover
60Hz Capacity Data.....	2
60Hz Electrical Data.....	2
Wiring Diagrams.....	3, 4
Dimensional Data.....	5
Alco TXV Selections.....	6
Sporlan TXV Selections.....	7
Pictorial Views.....	8
Application.....	8
Installation.....	8
Inspection.....	8
Location.....	8
Mounting.....	9
Drain Line.....	9
Piping.....	9
Wiring.....	9
System Check.....	9
Maintenance.....	9
Service Parts List.....	10
Project Information.....	Back

60Hz SPECIFICATIONS

Capacity Data - (BTUH) @ 10°F TD 60Hz

MODEL JUCC		119E	123E	129E	238E	246E	253E	260E	370E	380E	388E
EVAP TEMPERATURE °F											
+20/+25		19000	23000	29000	38000	46000	53000	60000	70000	80000	88000
+10		18620	22540	28420	37240	45080	51940	58800	68600	78400	86240
0		18050	21850	27550	36100	43700	50350	57000	66500	76000	83600
-10		17290	20930	26390	34580	41860	48230	54600	63700	72800	80080
-20		16150	19550	24650	32300	39100	45050	51000	59500	68000	74800
-30		15010	18170	22910	30020	36340	41870	47400	55300	63200	69520
-40		13680	16560	20880	27360	33120	38160	43200	50400	57600	63360
CFM		3100	4700	4550	9400	9400	9200	9100	13650	13650	13650
REFRIGERANT CHARGE*	LBS KG	5.8 2.7	5.4 2.4	8.2 3.7	8.5 3.9	10.8 4.9	12.6 5.7	16.1 7.3	19.6 8.9	22.4 10.2	24.5 11.2

* R404A at -20°F S.S.T. with coil 30% full

Electrical Data 60HZ 208-230/3/60

MODEL	FAN MOTORS				DEFROST HEATERS			
	QTY	TOTAL FLA	MIN. CIRC. AMPACITY	MAX. FUSE (AMPS)	WATTS	AMPS	MIN. CIRC. AMPACITY	MAX. FUSE (AMPS)
JUCC119E Z	1	2.0	2.5	15	4320	11.2	14	20
JUCC123E Z	1	2.0	2.5	15	6100	15.8	19.8	25
JUCC129E Z	1	2.0	2.5	15	6100	15.8	19.8	25
JUCC238E Z	2	4.0	4.5	15	11680	30.2	37.8	45
JUCC246E Z	2	4.0	4.5	15	11680	30.2	37.8	45
JUCC253E Z	2	4.0	4.5	15	11680	30.2	37.8	45
JUCC260E Z	2	4.0	4.5	15	11680	30.2	37.8	45
JUCC370E Z	3	6.0	6.5	15	17250	44.7	55.9	60
JUCC380E Z	3	6.0	6.5	15	17250	44.7	55.9	60
JUCC388E Z	3	6.0	6.5	15	17250	44.7	55.9	60

460/3/60

MODEL	FAN MOTORS				DEFROST HEATERS			
	QTY	TOTAL FLA	MIN. CIRC. AMPACITY	MAX. FUSE (AMPS)	WATTS	AMPS	MIN. CIRC. AMPACITY	MAX. FUSE (AMPS)
JUCC119E Y	1	1.0	1.25	15	4320	5.6	7	15
JUCC123E Y	1	1.0	1.25	15	6100	7.9	9.9	15
JUCC129E Y	1	1.0	1.25	15	6100	7.9	9.9	15
JUCC238E Y	2	2.0	2.25	15	11680	15.1	18.9	25
JUCC246E Y	2	2.0	2.25	15	11680	15.1	18.9	25
JUCC253E Y	2	2.0	2.25	15	11680	15.1	18.9	25
JUCC260E Y	2	2.0	2.25	15	11680	15.1	18.9	25
JUCC370E Y	3	3.0	3.25	15	17250	22.3	27.9	30
JUCC380E Y	3	3.0	3.25	15	17250	22.3	27.9	30
JUCC388E Y	3	3.0	3.25	15	17250	22.3	27.9	30

575/3/60

MODEL	FAN MOTORS				DEFROST HEATERS			
	QTY	TOTAL FLA	MIN. CIRC. AMPACITY	MAX. FUSE (AMPS)	WATTS	AMPS	MIN. CIRC. AMPACITY	MAX. FUSE (AMPS)
JUCC119E L	1	0.8	1	15	4320	4.5	5.6	15
JUCC123E L	1	0.8	1	15	6100	6.3	7.9	15
JUCC129E L	1	0.8	1	15	6100	6.3	7.9	15
JUCC238E L	2	1.6	1.8	15	11680	12.1	15.1	20
JUCC246E L	2	1.6	1.8	15	11680	12.1	15.1	20
JUCC253E L	2	1.6	1.8	15	11680	12.1	15.1	20
JUCC260E L	2	1.6	1.8	15	11680	12.1	15.1	20
JUCC370E L	3	2.4	2.6	15	17250	17.9	22.4	25
JUCC380E L	3	2.4	2.6	15	17250	17.9	22.4	25
JUCC388E L	3	2.4	2.6	15	17250	17.9	22.4	25

All Fan Motors are 3/4 H.P.

50Hz SPECIFICATIONS

Capacity Data - (BTUH) @ 10°F TD 50Hz

MODEL JUCC											
EVAP TEMPERATURE °F	119E	123E	129E	238E	246E	253E	260E	370E	380E	388E	
+20/+25	17480	21160	26680	34960	42320	48760	55200	64400	73600	80960	
+10	17130	20737	26146	34261	41474	47785	54096	63112	72128	79341	
0	16606	20102	25346	33212	40204	46322	52440	61180	69920	76912	
-10	15907	19256	24279	31814	38511	44372	50232	58604	66976	73674	
-20	14858	17986	22678	29716	35972	41446	46920	54740	62560	68816	
-30	13809	16716	21077	27618	33433	38520	43608	50876	58144	63958	
-40	12586	15235	19210	25171	30470	35107	39744	46368	52992	58291	
CFM	2570	3900	3780	7800	7800	7800	7550	11330	13650	13650	
REFRIGERANT CHARGE*	LBS KG	5.8 2.7	5.4 2.4	8.2 3.7	8.5 3.9	10.8 4.9	12.6 5.7	16.1 7.3	19.6 8.9	22.4 10.2	24.5 11.2

* R404A at -20°F S.S.T. with coil 30% full

Electrical Data 50HZ

200-220/3/50

MODEL	FAN MOTORS				DEFROST HEATERS			
	QTY	TOTAL FLA	MIN. CIRC. AMPACITY	MAX. FUSE (AMPS)	WATTS	AMPS	MIN. CIRC. AMPACITY	MAX. FUSE (AMPS)
JUCC119EZ	1	1.7	2.13	15	3950	10.7	13.4	15
JUCC123EZ	1	1.7	2.13	15	5580	14.5	18.1	20
JUCC129E Z	1	1.7	2.13	15	5580	14.5	18.1	20
JUCC238E Z	2	3.4	3.83	15	10685	27.7	34.6	40
JUCC246E Z	2	3.4	3.83	15	10685	27.7	34.6	40
JUCC253E Z	2	3.4	3.83	15	10685	27.7	34.6	40
JUCC269E Z	2	3.4	3.83	15	10685	27.7	34.6	40
JUCC370E Z	3	5.1	5.53	15	15785	40.9	51.1	55
JUCC380E Z	3	5.1	5.53	15	15785	40.9	51.1	55
JUCC388E Z	3	5.1	5.53	15	15785	40.9	51.1	55

380-400/3/50

MODEL	FAN MOTORS				DEFROST HEATERS			
	QTY	TOTAL FLA	MIN. CIRC. AMPACITY	MAX. FUSE (AMPS)	WATTS	AMPS	MIN. CIRC. AMPACITY	MAX. FUSE (AMPS)
JUCC119E Y	1	0.8	1.0	15	4320	6.8	8.5	15
JUCC123E Y	1	0.8	1.0	15	6100	9.6	12	15
JUCC129E Y	1	0.8	1.0	15	6100	9.6	12	15
JUCC238E Y	2	1.6	1.8	15	11680	18.3	22.9	25
JUCC246E Y	2	1.6	1.8	15	11680	18.3	22.9	25
JUCC253E Y	2	1.6	1.8	15	11680	18.3	22.9	25
JUCC260E Y	2	1.6	1.8	15	11680	18.3	22.9	25
JUCC370E Y	3	2.4	2.6	15	17250	27	33.8	40
JUCC380E Y	3	2.4	2.6	15	17250	27	33.8	40
JUCC388E Y	3	2.4	2.6	15	17250	27	33.8	40

All Fan Motors are 3/4 H.P.

WIRING DIAGRAM

UNIT COOLER WIRING DIAGRAM - ELECTRIC DEFROST

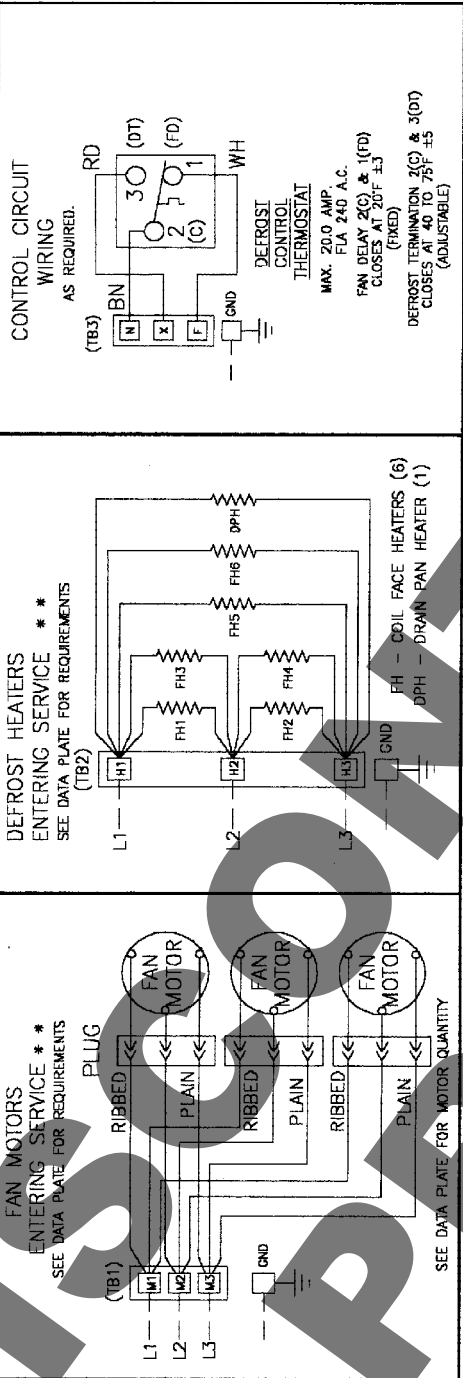

TYPICAL FIELD WIRING ** WITH TIME CLOCK AND FAN CONTACTOR (SINGLE UNIT COOLER)

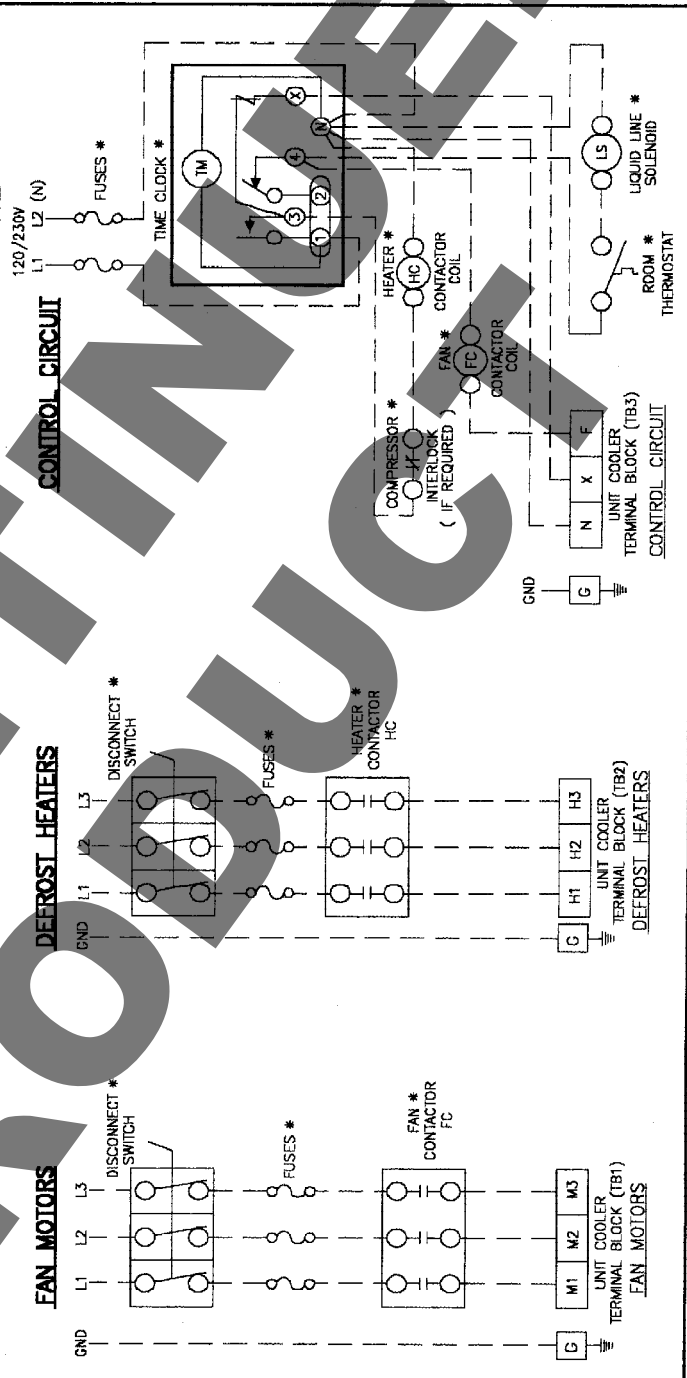

WIRING DIAGRAM

TYPICAL FIELD WIRING ** WITH TIME CLOCK AND FAN CONTACTOR (MULTIPLE UNIT COOLERS.)

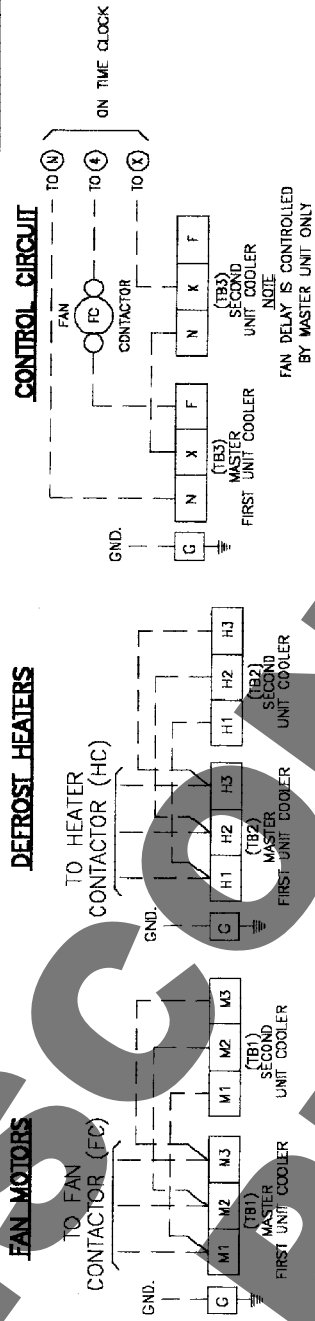

ELECTRICAL COMPONENT & DEFROST HEATER LAYOUT

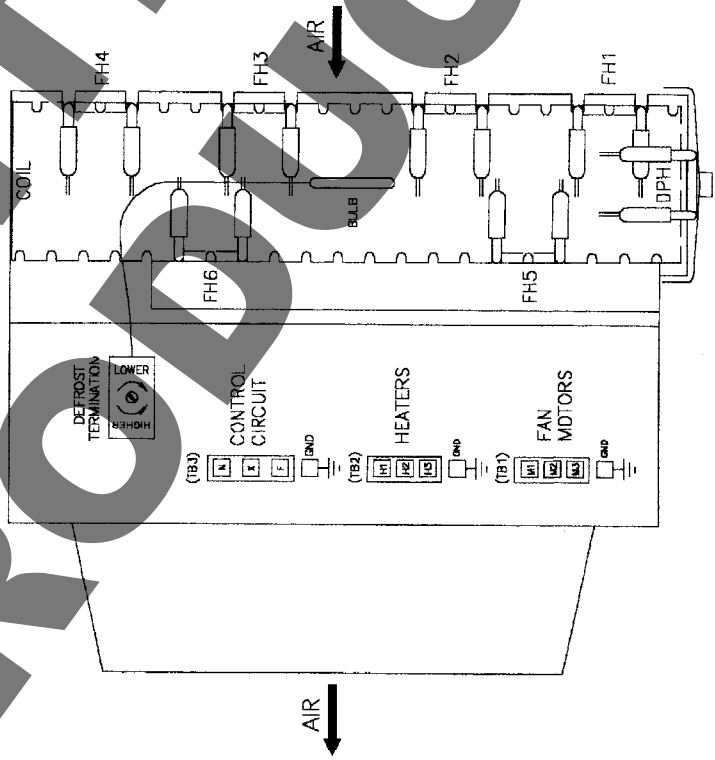

NOTES

- * COMPONENTS BY OTHERS FACTORY WIRING WIRING BY OTHERS
- ** ALL FIELD WIRING TO BE IN COMPLIANCE WITH ALL APPLICABLE LOCAL AND NATIONAL CODES.

1D48649-B

DIMENSIONAL DATA

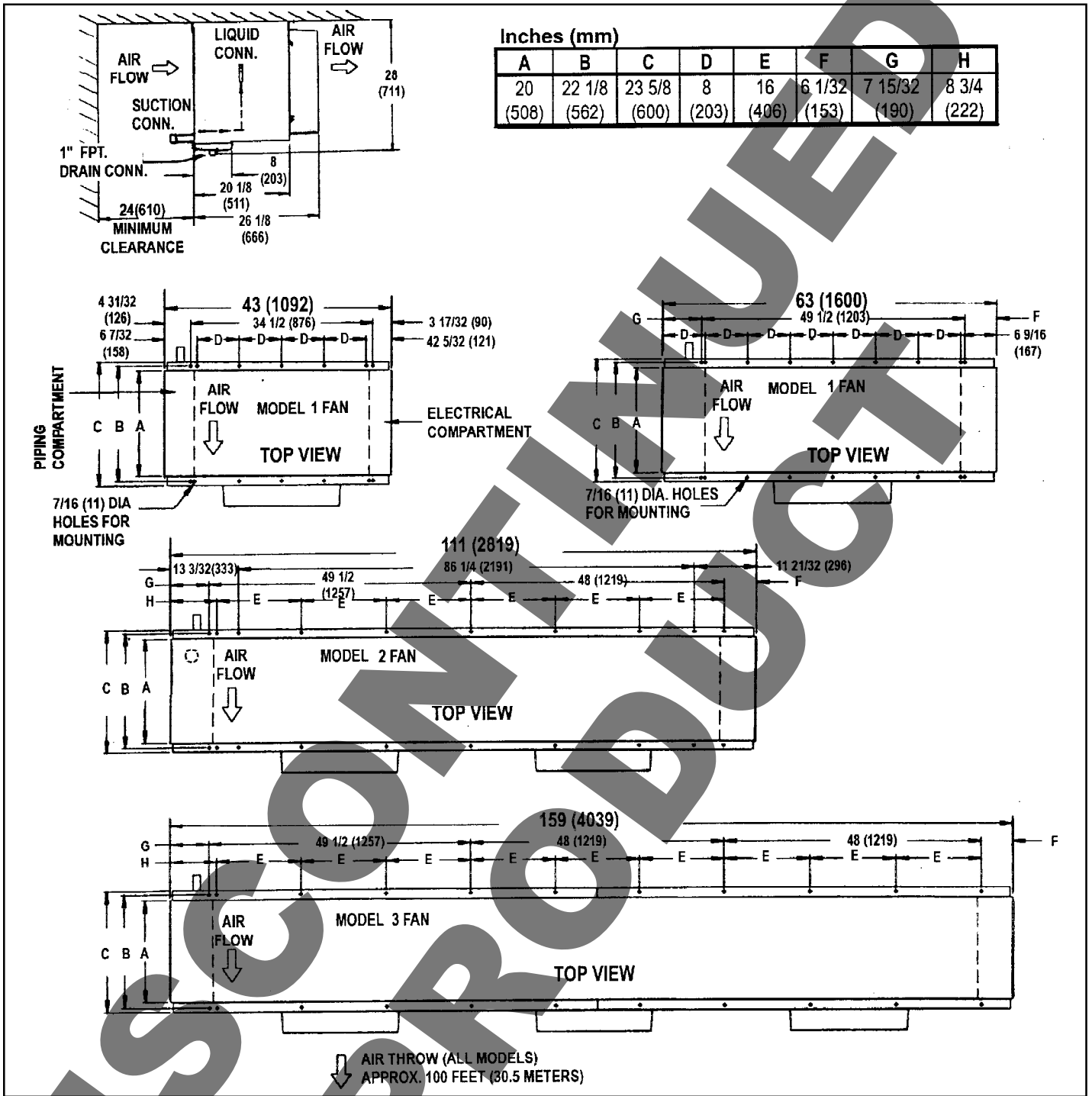

DIMENSIONAL DATA INCHES (MILLIMETERS)

Electric Defrost Model		119	123	129	238	246	253	260	370	380	388
Number of Fans		1	1	1	2	2	2	2	3	3	3
Liquid Connection (O.D. Sweat)		5/8 (16)	7/8 (22)	7/8 (22)	7/8 (22)	7/8 (22)	7/8 (22)	7/8 (22)	7/8 (22)	1 1/8 (29)	1 1/8 (29)
Suction Connection (O.D. Sweat)		7/8 (22)	1 1/8 (29)	1 3/8 (35)	1 3/8 (35)	1 5/8 (41)	1 5/8 (41)	1 5/8 (41)	1 5/8 (41)	2 1/8 (54)	2 1/8 (54)
Approx. Shipping Weight	Lbs.	160	190	205	350	370	380	390	540	560	580
	Kg	73	86	93	159	168	173	177	245	227	264

ALCO TXV SELECTIONS

R404A - R507		MODEL JUCC									
EVAP TEMP	119E		123E		129E		238E		246E		
	BTUH	VALVE #	BTUH	VALVE#	BTUH	VALVE #	BTUH	VALVE #	BTUH	VALVE #	
+20/+25°F	19000	HFES 1 1/2-RC	23000	HFES 1 1/2-RC	29000	HFES 2-RC	38000	HFES 3 1/2-RC	46000	HFES 3 1/2-RC	
+10°F	18620		22540		28420		37240		45080		
0°F	18050		21850		27550		36100		43700		
-10°F	17290	HFES 1 1/2-RZ	20930	HFES 2-RZ	26390	HFES 3 1/2-RZ	34580	HFES 3 1/2-RZ	41860	HFES 5-RZ	
-20°F	16150		19550		24650		32300		39100		
-30°F	15010		18170		22910		30020		36340		
-40°F	13680		HFES 2-RZ		16560		20880		27360		33120
EVAP TEMP	253E		260E		370E		380E		388E		
	BTUH	VALVE #	BTUH	VALVE #	BTUH	VALVE #	BTUH	VALVE #	BTUH	VALVE #	
+20/+25°F	53000	HFES 3 1/2-RC	60000	HFES 3 1/2-RC	70000	HFES 5-RC	80000	HFES 5-RC	88000	HFES 7-RC	
+10°F	51940		58800		68600		78400		86240		
0°F	50350		57000		66500		76000		83600		
-10°F	48230	HFES 5-RZ	54600	HFES 5-RZ	63700	HFES 7-RZ	72800	HFES 7-RZ	80080	HFES 10-RZ	
-20°F	45050		51000		59500		68000		74800		
-30°F	41870		47400		55300		63200		69520		
-40°F	38160		HFES 7-RZ		43200		50400		57600		63360

R22		MODEL JUCC									
EVAP TEMP	119E		123E		129E		238E		246E		
	BTUH	VALVE #	BTUH	VALVE#	BTUH	VALVE #	BTUH	VALVE #	BTUH	VALVE #	
+20/+25°F	19000	HFES 1 1/2-HC	23000	HFES 1 1/2-HC	29000	HFES 2-HC	38000	HFES 2 1/2-HC	46000	HFES 3-HC	
+10°F	18620		22540		28420		37240		45080		
0°F	18050		21850		27550		36100		43700		
-10°F	17290	HFES 2-HZ	20930	HFES 2 1/2-HZ	26390	HFES 2 1/2-HZ	34580	HFES 3-HZ	41860	HFES 5 1/2-HZ	
-20°F	16150		19550		24650		32300		39100		
-30°F	15010		18170		22910		30020		36340		
-40°F	13680		HFES 2 1/2-HZ		16560		20880		27360		33120
EVAP TEMP	253E		260E		370E		380E		388E		
	BTUH	VALVE #	BTUH	VALVE #	BTUH	VALVE #	BTUH	VALVE #	BTUH	VALVE #	
+20/+25°F	53000	HFES 3-HC	60000	HFES 5 1/2-HC	70000	HFES 5 1/2-HC	80000	HFES 5 1/2-HC	88000	HFES 5 1/2-HC	
+10°F	51940		58800		68600		78400		86240		
0°F	50350		57000		66500		76000		83600		
-10°F	48230	HFES 5 1/2-HZ	54600	HFES 5 1/2-HZ	63700	HFES 8-HZ	72800	HFES 8-HZ	80080	HFES 10-HZ	
-20°F	45050		51000		59500		68000		74800		
-30°F	41870		47400		55300		63200		69520		
-40°F	38160		HFES 8-HZ		43200		50400		57600		63360

R134a		MODEL JUCC									
EVAP TEMP	119E		123E		129E		238E		246E		
	BTUH	VALVE #	BTUH	VALVE#	BTUH	VALVE #	BTUH	VALVE #	BTUH	VALVE #	
+20/+25°F	19000	HFES 1 1/2-MC	23000	HFES 1 3/4-MC	29000	HFES 1 3/4-MC	38000	HFES 2 1/2-MC	46000	HFES 4-MC	
+10°F	18620		22540		28420		37240		45080		
0°F	18050		21850		27550		36100		43700		
EVAP TEMP	253E		260E		370E		380E		388E		
	BTUH	VALVE #	BTUH	VALVE #	BTUH	VALVE #	BTUH	VALVE #	BTUH	VALVE #	
+20/+25°F	53000	HFES 4-MC	60000	HFES 4-MC	70000	HFES 6-MC	80000	HFES 6-MC	88000	HFES 6-MC	
+10°F	51940		58800		68600		78400		86240		
0°F	50350		57000		66500		76000		83600		

Where available use the HFESC series valve which includes sweat fittings with a removable/cleanable inlet screen.

Note: Above Selections are based on 100 °F Entering Liquid Temperature.

VENTURI - FLO distributor does not require the selection or use of distributor nozzles.

SPORLAN TXV SELECTIONS

R502* - 404A - R507		MODEL JUCC								
EVAP TEMP	119E		123E		129E		238E		246E	
	BTUH	VALVE #	BTUH	VALVE #	BTUH	VALVE #	BTUH	VALVE #	BTUH	VALVE #
+20/25 °F	19000	EGSE 1 1/2-C	23000	EGSE	29000	EGSE 2-C	38000	SSE 3-C	46000	SSE 4-C
+10 °F	18620		22540	1 1/2-C	28420		37240		45080	
0 °F	18050		21850	EGSE 2-C	27550		36100		43700	
-10 °F	17290	EGSE 1 1/2-ZP	20930	EGSE 2-ZP	26390	EGSE 2-ZP	34580	SSE 3-ZP	41860	SSE 4-ZP
-20 °F	16150		19550		24650	SSE 3-ZP	32300	39100		
-30 °F	15010		18170		22910	30020	SSE 4-ZP	36340		
-40 °F	13680		16560		20880	27360	33120			
EVAP TEMP	253E		260E		370E		380E		388E	
BTUH	VALVE #	BTUH	VALVE #	BTUH	VALVE #	BTUH	VALVE #	BTUH	VALVE #	
+20/25 °F	53000	SSE 4-C	60000	SSE 4-C	70000	SSE 6-C	80000	SSE 7-C	88000	SSE 7-C
+10 °F	51940		58800	SSE 6-C	68600	78400	86240			
0 °F	50350		57000	SSE 7-C	66500	76000	83600		EBSSE 7 1/2-C	
-10 °F	48230	SSE 4-ZP	54600	SSE 6-ZP	63700	SSE 6-ZP	72800	SSE 7-ZP	80080	SSE 7-ZP
-20 °F	45050	SSE 6-ZP	51000		59500	68000	74800			
-30 °F	41870		47400		55300	SSE 7-ZP	63200	OSE 9-ZP	69520	OSE 9-ZP
-40 °F	38160		43200		SSE 7-ZP	50400	57600	63360		

R22		MODEL JUCC								
EVAP TEMP	119E		123E		129E		238E		246E	
	BTUH	VALVE #	BTUH	VALVE #	BTUH	VALVE #	BTUH	VALVE #	BTUH	VALVE #
+20/25 °F	19000	EGVE 1 1/2-C	23000	EGVE	29000	EGVE 2-C	38000	EGVE 3-C	46000	EGVE 3-C
+10 °F	18620		22540	1 1/2-C	28420	37240	45080			
0 °F	18050		21850	EGVE 2-C	27550	EGVE 3-C	36100		43700	
-10 °F	17290	EGVE 2-ZP40	20930	EGVE 2-ZP40	26390	EGVE 3-ZP40	34580	SVE 4-ZP40	41860	SVE 4-ZP40
-20 °F	16150		19550		24650		32300		39100	
-30 °F	15010		18170		22910		30020		36340	
-40 °F	13680		16560		20880		27360		33120	
EVAP TEMP	253E		260E		370E		380E		388E	
BTUH	VALVE #	BTUH	VALVE #	BTUH	VALVE #	BTUH	VALVE #	BTUH	VALVE #	
+20/25 °F	53000	SVE 4-C	60000	SVE 4-C	70000	SVE 5-C	80000	SVE 8-C	88000	SVE 8-C
+10 °F	51940		58800	SVE 5-C	68600	78400	86240			
0 °F	50350		57000	SVE 8-C	66500	76000	83600			
-10 °F	48230	SVE 5-ZP40	54600	SVE 5-ZP40	63700	SVE 8-ZP40	72800	SVE 8-ZP40	80080	SVE 10-ZP40
-20 °F	45050		51000	SVE 8-ZP40	59500	63200	74800			
-30 °F	41870		47400	SVE 8-ZP40	55300	57600	69520			
-40 °F	38160		43200	SVE 8-ZP40	50400	57600	63360			

R12* - R134a		MODEL JUCC								
EVAP TEMP	119E		123E		129E		238E		246E	
	BTUH	VALVE #	BTUH	VALVE #	BTUH	VALVE #	BTUH	VALVE #	BTUH	VALVE #
+20/25 °F	19000	EGJE 1 1/2-C	23000	EGJE	29000	EGJE 2-C	38000	SJE 2 1/2-C	46000	SJE 3-C
+10 °F	18620		22540	1 1/2-C	28420		37240		45080	
0 °F	18050		21850	EGJE 2-C	27550		36100		43700	
EVAP TEMP	253E		260E		370E		380E		388E	
BTUH	VALVE #	BTUH	VALVE #	BTUH	VALVE #	BTUH	VALVE #	BTUH	VALVE #	
+20/25 °F	53000	SJE 5-C	60000	SJE 5-C	70000	SJE 5-C	80000	SJE 6-C	88000	EBSJE 7-C
+10 °F	51940		58800		SJE 6-C	68600	78400		86240	
0 °F	50350		57000		SJE 5-C	66500	76000		83600	

* Valve part numbers are coded for R404A (also may be used on R502 or R507) and R134a (also may be used on R12)

Note: Above Selections are based on 100 °F Entering Liquid Temperature.
 VENTURI - FLO distributor does not require the selection or use of distributor nozzles.

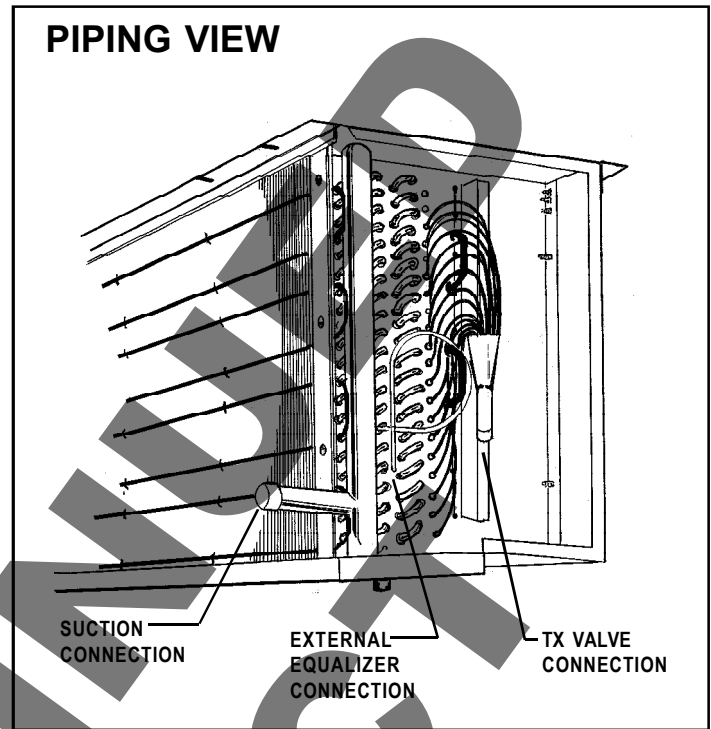
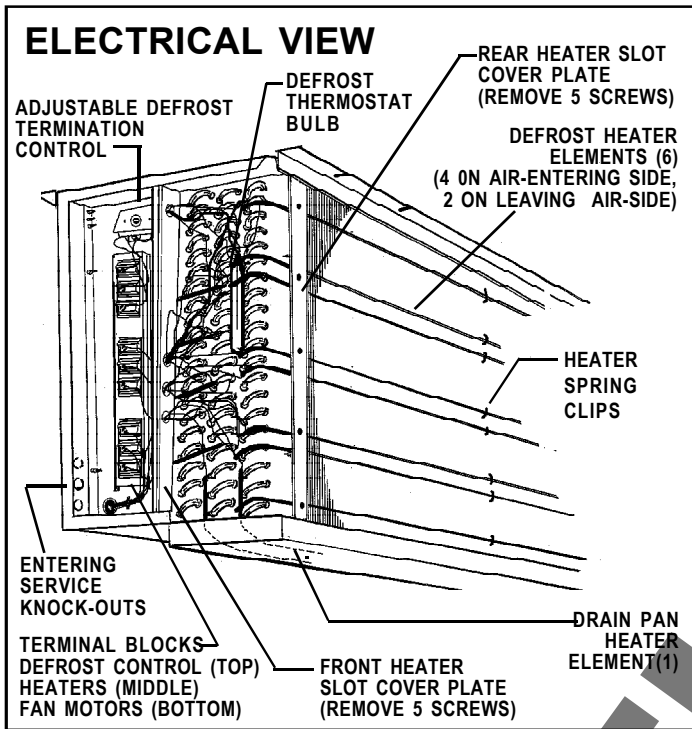

APPLICATION

These Unit Coolers are designed for use with R12, R22, R134a, R404A, R407A/B/C, R507 or R502 refrigerants.

At room temperatures above 34°F and evaporating temps no lower than 27°F the air flowing through the coil will accomplish the defrost. Temperatures of 34°F and below (to -40°F) require positive defrosting (either Electric or Hot Gas). These models require the use of (1) Time Clock (to initiate and terminate the defrost cycle). (2) Fan-Delay thermostat (to prevent evaporator fans from starting up right after defrost and blowing water on to fan blades, guards and floor) (3) Defrost Termination Control (to prevent unnecessary prolonged heating and steaming of the coil once all the ice and frost has melted).

The coil must not be exposed to any abnormal atmospheric or acidic environments. This may result in corrosion to the cabinet and possible coil failure (leaks). (Consult manufacturer for optional baked on phenolic protective coatings).

INSTALLATION

The installation and start-up of Unit Coolers should only be performed by qualified refrigeration mechanics.

This equipment should be installed in accordance with all applicable codes, ordinances and local by-laws.

INSPECTION

Inspect all equipment before unpacking for visible signs of damage or loss. Check shipping list against material received to ensure shipment is complete.

IMPORTANT: Remember, you, the consignee, must make any claim necessary against the transportation company. Shipping damage or missing parts, when discovered at the outset, will prevent later unnecessary and costly delays.

If damage or loss during transport is evident, make claim to carrier, as this will be their responsibility, not the manufacturer's.

Should carton be damaged, but damage to equipment is not obvious, a claim should be filed for "concealed damage" with the carrier.

IMPORTANT: The electrical characteristics of the unit should be checked at this time to make sure they correspond to those ordered and to electrical power available at the job site.

Save all shipping papers, tags and instruction sheets for reference by installer and owner.

LOCATION

The unit location in the room should be selected to ensure uniform air distribution throughout the entire space to be refrigerated. Be sure that the unit does not draw air in, or blow directly out, through an opened door and that the product does not obstruct the free circulation of air. Allow a minimum of 24" clearance at each end and behind the unit.

The Unit Coolers draw air through the coil and discharge air from the fan side.

Consideration should be given to the coil location in order to minimize the piping run length to the condensing unit and floor drain.

MOUNTING

Mounting brackets with 7/16" dia holes are provided for flush mounting to the ceiling. For details refer to dimensional data on page 6. Ensure adequate clearance (at least 24") is provided behind the coil as well as each side (to enable access to the electrical and refrigeration compartments).

Ensure that the ceiling is level since the drain pan has been sloped for drainage during the defrost cycle.

DRAIN LINE

The drain line should be run from the drain connection, sloping at least 4" per foot. A trap outside the room will prevent warm air from entering through the tubing. Connection should be made to proper drainage facilities that comply with local regulations.

To prevent freeze-up when the temperature of the refrigerated space is 32 °F or lower, the drain line should be heated along its run inside the cold room. The heated drain line should be insulated. It is recommended that the heater be energized at all times. A heat input of 20 watts per foot in a 0 °F room and 30 watts per foot in a -20 °F room is usually satisfactory.

The drain pan may be mounted with the drain fitting at either end (remove pan heater and relocate pan). See page 6 for drain fitting details.

Ensure that the drain pan has sufficient slope for proper drainage (prevention of ice build up/blockage in pan).

PIPING

Refrigerant line sizes are important and may not be the same size as the coil connections. (depends on the length of run) If in doubt, consult "Recommended refrigerant line sizes" charts. (Engineering Manuals or other recognized sources of information).

WIRING

Wire system in accordance with governing standards and local codes. See data and wiring diagrams on pages 2, 3, 4 and 5 for wiring arrangement. Electrical wiring is to be sized in accordance with minimum circuit ampacity rating.

For ease of identifying the proper wiring terminals, unit wiring is colour coded and terminal block connections are identified. When **fan delay thermostats** (combination fan delay and defrost termination) are installed, on start-up, the fans do not operate until the coil temperature is reduced to approximately 20 °F. It is normal for the fans to cycle a few times until the room temperature is brought down. At higher evaporating temperatures this control may not close and therefore should be by-passed or replaced with an adjustable type.

The **defrost termination control** is adjustable and may be set at a minimum of 40 °F (fully CW) to a maximum of 75 °F (fully CCW). Normal setting is 55 °F. This can be increased if the defrost heaters are terminated too soon (frost still left) or decreased if terminated too long (steaming of coil). Time clock should be set for a fail-safe time termination of 30 minutes.

SYSTEM CHECK

Before Start-Up:

1. All wiring should be in accordance with local codes.
2. Refrigerant lines should be properly sized.
3. Electric defrost systems should include a liquid line solenoid valve.
4. Thorough evacuation and, dehydration has been performed.
5. The suction, discharge, and receiver service valves must be open.
6. The system should include a liquid line drier moisture indicator and suction filter.
7. Pour enough water into the drain pan to allow a good check on drainage and seal the trap.

After Start-Up:

1. If necessary, temporarily by-pass fan delay control to run fans until room temp is lowered. (Run jumper wire from terminal N to F on control circuit terminal block).
2. Check the compressor oil level to ensure the correct oil charge.
3. Be sure that the expansion valve is properly set to provide the correct amount of superheat. (should be around 5 to 6 °F for 10 °F T.D. operation).
4. Heavy moisture loads are usually encountered when starting the system for the first time. If the coil temperature is below freezing, this will cause a rapid build-up of frost on the coil. During the initial pull-down frost build-up should be watched and the coil defrosted manually, as required.
5. Check for proper evaporator fan blade rotation.

MAINTENANCE

The unit should be periodically inspected for any dirt or build-up on the fin surface and cleaned if necessary with a soft whisk or brush. Also ensure coil and pan does not have any excessive ice build-up from improper defrost operation. When replacing heater elements first remove heater slot covers and heater clips. (See page 9 for detailed view).

SERVICE PARTS LIST

FAN MOTORS - 60Hz 208-230/1/60 208-230/3/60 460/3/60 575/3/60	MODELS ALL ALL ALL ALL	PART # 1045032 1045033 1045034 1045035
FAN BLADES 20" 18° Pitch 4-Blade 20" 23° Pitch 4-Blade	MODELS 120E ALL (EXCEPT 120E)	PART # 1048568 1045115
FAN GUARDS Moulded Throw Booster (standard) Metal Wire (optional) Acorn Nut	MODELS ALL ALL ALL	PART # 1045089 1045091 1045138
Motor Mount	MODELS ALL	PART # 1045031
Terminal Block - Fan Motor Terminal Block - Defrost Heaters Terminal Block - Control Defrost Control Thermostat Face Heater Clip	MODELS ALL ALL ALL ALL ALL	PART # 1045017 1045018 1045017 1048610 1048609

MODEL	COIL FACE HEATERS (6 REQUIRED)			DRAIN PAN HEATER (1 REQUIRED)		
	230V	460V	575V	230V	460V	575V
119	1045039-001	1045039-003	1045039-004	1045039-017	1045039-019	1045039-020
123, 129	1045039-005	1045039-007	1045039-008	1045039-021	1045039-023	1045039-024
238, 246, 253, 260	1045039-009	1045039-011	1045039-012	1045039-025	1045039-027	1045039-028
370, 380, 388	1045039-013	1045039-015	1045039-016	1045039-029	1045039-031	1045039-032

SERVICE LOG

DATE	COMMENTS

PROJECT INFORMATION

System	
Model Number	Date of Start-Up
Serial Number	Service Contractor
Refrigerant	Phone
Electrical Supply	Fax

DISCONTINUED PRODUCT



NATIONAL REFRIGERATION & AIR CONDITIONING CANADA CORP.
 159 ROY BLVD., BRANTFORD, ONTARIO, CANADA N3R 7K1
 PHONE: 1-800-463-9517 (519)751-0444 FAX (519)753-1140



ANSI/NSF 7 1R71

Due to National Refrigeration's policy of continuous product improvement, we reserve the right to make changes without notice.