



# KLP **Generation E** Low Profile Evaporator

## PRODUCT DATA & INSTALLATION

Part # 1112451

	<b>PRODUCT SUPPORT</b>	<i>scan:</i> 
	web: <a href="http://www.k-rp.com/klp">www.k-rp.com/klp</a>	
	email: <a href="mailto:evaps@k-rp.com">evaps@k-rp.com</a>	
	call: 1-844-893-3222 x520	

**Air, Electric, & Hot Gas Defrost**

Electrical Power:  
115/1/60, 208-230/1/60, 208-230/3/60

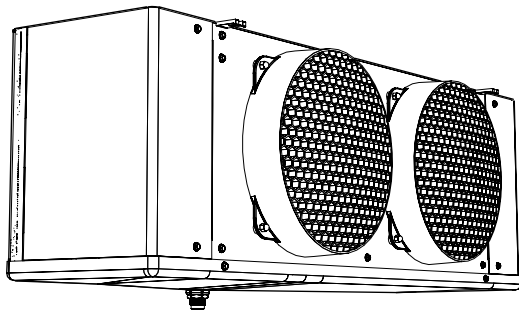

### CONTENTS

	Page
Nomenclature .....	2
Features & Options .....	2
Selection Data .....	3
Electrical Data .....	4 - 9
Wiring Diagrams - Models with <b>ESP+</b> .....	10 - 15
Annual Walk-In Energy Factor (AWEF) Ratings/ Sound Data .....	16
Dimensional Data/ Specifications .....	17
Shipping Weights .....	18
Expansion Valve Selections - Models with <b>ESP+</b> .....	19
Installation Instructions .....	20 - 21
<b>A2L</b> Installation Instructions .....	22 - 27
Hot Gas Piping Schematics .....	28 - 29
Defrost Kit and Fuse Package Selections / Details .....	30 - 33
Project Information .....	34 - 38
Product Support Resources: Service Parts, Troubleshooting, Warranty, etc .....	39
"As Built" Service Parts .....	BACK

# NOMENCLATURE

# KLP - LOW PROFILE EVAPORATORS

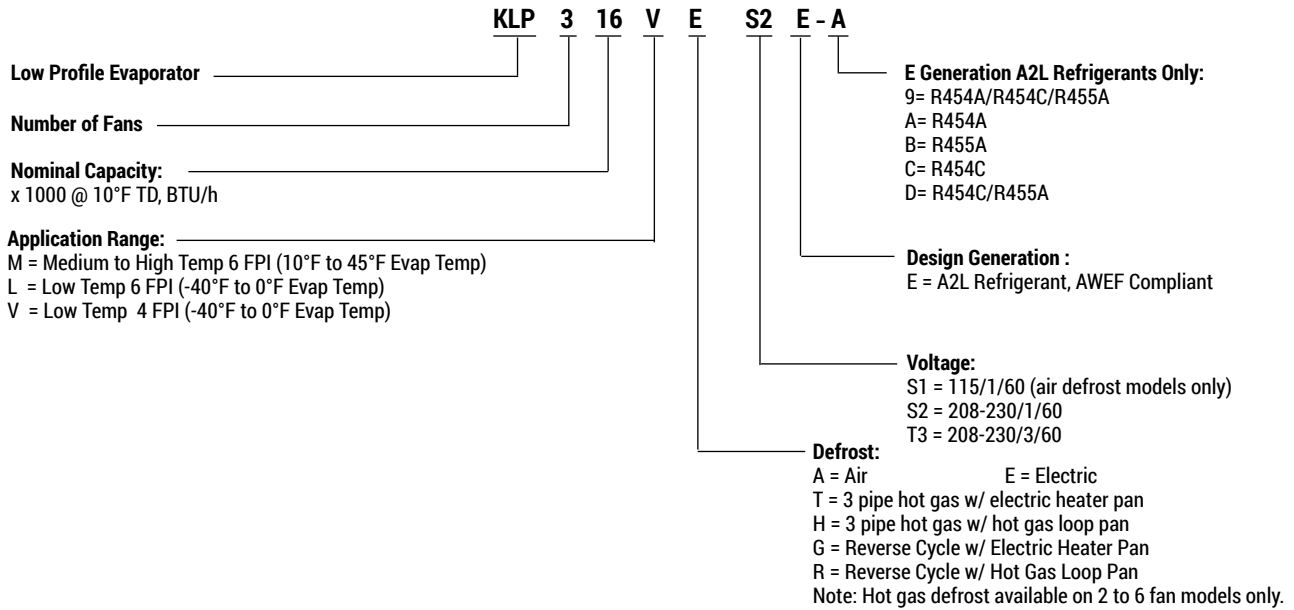

## STANDARD FEATURES

- ESP+ Intuitive Evaporator Control Technology.
- EC motors with patented SmartSpeed® Technology.
- High efficiency and high strength fan guard
- Front access
- Internally enhanced tubing
- Convenient mounting brackets
- Ample electrical and header compartments
- Liquid line solenoid valve wire harness factory installed
- Schrader valve on suction header
- Positive slope, hinged drain pan
- Central drain connections (approximate)
- Universal drain fitting
- Large 3/4" ID (3/4" MPT) drain hole
- Factory installed distributor nozzle
- All A2L units will include a Leak detection system with shipped loose SSOV (Safety Shut Off Valve) and CSOV (Check Shut Off Valve)

## AVAILABLE OPTIONS

- Hot gas loop pan with hot gas defrost models
- Factory installed expansion valve, solenoid valve and room thermostat
- Wire fan guard
- Corrosion protection: alternate fin materials and coatings
- Transducer Schrader with service isolation valve
- Additional options available, please contact factory

**R454A - R454C - R455A**  
**Medium Temperature - 6 FPI Models**

Model KLP	Qty. Fans	Evaporator Temperature Selection Capacity BTU/h			Air Flow		Refrig. Charge R454A- R455A - R454C	
		20/25°F (-4/-7°C)	15°F (-9°C)	10°F (-12°C)	CFM	L/S	LB.	KG
105M	1	4700	4650	4610	750	350	0.9	(0.4)
107M		6400	6340	6270	705	330	1.1	(0.5)
108M		7600	7520	7450	680	320	1.3	(0.6)
210M	2	9500	9410	9310	1500	710	1.3	(0.6)
212M		12400	12300	12150	1410	670	1.6	(0.7)
215M		14900	14800	14600	1360	640	1.9	(0.8)
318M	3	18400	18200	18030	2115	1000	2.0	(0.9)
322M		22100	21900	21660	2040	960	2.4	(1.1)
424M	4	24400	24200	23910	2820	1330	2.5	(1.1)
429M		29400	29100	28810	2720	1280	3.1	(1.4)
537M		36700	36300	35970	3400	1600	3.7	(1.7)
644M	6	44000	43600	43120	4080	1930	4.3	(1.9)

The above capacities were rated based on nominal 10 TD  
 Capacities at other TD within a range of 8 to 15 °F (4.4 to 8.3°C) are directly proportional to TD, or use formula:  
 Capacity = Rated capacity ÷ 10 x TD.

**R454A - R454C - R455A**  
**Low Temperature - 6 FPI Models**

Model KLP	Qty. Fans	Evaporator Temperature Selection Capacity BTU/h					Air Flow		Refrig. Charge R454A - R455A - R454C	
		0°F (-18°C)	-10°F (-23°C)	-20°F (-29°C)	-30°F (-34°C)	-40°F (-40°C)	CFM	L/S	LB.	KG
104L	1	4310	4190	4070	3740	3460	750	350	0.9	(0.4)
105L		5190	5050	4900	4510	4170	705	330	1.1	(0.5)
106L		6710	6520	6330	5820	5380	680	320	1.2	(0.6)
207L	2	7590	7370	7160	6590	6090	1500	710	1.2	(0.6)
209L		9950	9670	9390	8640	7980	1410	670	1.5	(0.7)
211L		11980	11600	11300	10400	9610	1360	640	1.8	(0.8)
314L	3	14730	14300	13900	12800	11800	2115	1000	1.9	(0.9)
316L		17170	16700	16200	14900	13800	2040	960	2.4	(1.1)
418L	4	19500	19000	18400	16900	15600	2820	1330	2.4	(1.1)
421L		22470	21800	21200	19500	18000	2720	1280	3.0	(1.3)
526L		27670	26900	26100	24000	22200	3400	1600	3.6	(1.6)
631L	6	32970	32000	31100	28600	26400	4080	1930	4.1	(1.9)

The above capacities were rated based on nominal 10 TD  
 Capacities at other TD within a range of 8 to 15 °F (4.4 to 8.3°C) are directly proportional to TD, or use formula:  
 Capacity = Rated capacity ÷ 10 x TD.

**R454A - R454C - R455A**  
**Low Temperature - 4 FPI Models**

Model KLP	Qty. Fans	Evaporator Temperature Selection Capacity BTU/h					Air Flow		Refrig. Charge R454A - R455A - R454C	
		0°F (-18°C)	-10°F (-23°C)	-20°F (-29°C)	-30°F (-34°C)	-40°F (-40°C)	CFM	L/S	LB.	KG
103V	1	3880	3770	3660	3370	3110	750	350	0.7	(0.3)
104V		4610	4480	4350	4000	3700	705	330	1.1	(0.5)
106V		5880	5720	5550	5110	4720	680	320	1.5	(0.7)
207V	2	7070	6870	6670	6140	5670	1500	710	1.3	(0.6)
208V		8590	8340	8100	7450	6890	1410	670	1.4	(0.6)
211V		11200	10900	10600	9750	9010	1360	640	2.0	(0.9)
313V	3	13400	13000	12600	11600	10700	2115	1000	3.0	(1.4)
316V		16500	16100	15600	14400	13300	2040	960	4.0	(1.8)
418V	4	18800	18200	17700	16300	15000	2820	1330	3.3	(1.5)
421V		22300	21600	21000	19300	17900	2720	1280	3.9	(1.8)
524V	5	25300	24600	23900	22000	20300	3400	1600	6.5	(2.9)
627V	6	28400	27600	26800	24700	22800	4080	1930	7.8	(3.5)

The above capacities were rated based on nominal 10 TD  
 Capacities at other TD within a range of 8 to 15 °F (4.4 to 8.3°C) are directly proportional to TD, or use formula:  
 Capacity = Rated capacity ÷ 10 x TD.

115/1/60: Air Defrost & Hot Gas Defrost with Hot Gas Loop Pan Models

Model KLP	FPI	FAN MOTORS					
		Qty.	Standard SMARTSPEED EC Motors				
			HP	FLA Total	Watts	MCA (A)	MOP (A)
105MA-S1E *	6	1	1/15	1.0	60	1.3	15
107MA-S1E *		1	1/15	1.0	60	1.3	15
108MA-S1E *		1	1/15	1.0	60	1.3	15
210M#-S1E		2	1/15	2.0	120	2.3	15
212M#-S1E		2	1/15	2.0	120	2.3	15
215M#-S1E		2	1/15	2.0	120	2.3	15
318M#-S1E		3	1/15	3.0	180	3.3	15
322M#-S1E		3	1/15	3.0	180	3.3	15
424M#-S1E		4	1/15	4.0	240	4.3	15
429M#-S1E		4	1/15	4.0	240	4.3	15
537M#-S1E		5	1/15	5.0	300	5.3	15
644M#-S1E		6	1/15	6.0	360	6.3	15
104Lt-S1E	6	1	1/15	1.0	60	1.3	15
105Lt-S1E		1	1/15	1.0	60	1.3	15
106Lt-S1E		1	1/15	1.0	60	1.3	15
207Lt-S1E		2	1/15	2.0	120	2.3	15
209Lt-S1E		2	1/15	2.0	120	2.3	15
211Lt-S1E		2	1/15	2.0	120	2.3	15
314Lt-S1E		3	1/15	3.0	180	3.3	15
316Lt-S1E		3	1/15	3.0	180	3.3	15
418Lt-S1E		4	1/15	4.0	240	4.3	15
421Lt-S1E		4	1/15	4.0	240	4.3	15
526Lt-S1E		5	1/15	5.0	300	5.3	15
631Lt-S1E		6	1/15	6.0	360	6.3	15
103Vt-S1E	4	1	1/15	1.0	60	1.3	15
104Vt-S1E		1	1/15	1.0	60	1.3	15
106Vt-S1E		1	1/15	1.0	60	1.3	15
207Vt-S1E		2	1/15	2.0	120	2.3	15
208Vt-S1E		2	1/15	2.0	120	2.3	15
211Vt-S1E		2	1/15	2.0	120	2.3	15
313Vt-S1E		3	1/15	3.0	180	3.3	15
316Vt-S1E		3	1/15	3.0	180	3.3	15
418Vt-S1E		4	1/15	4.0	240	4.3	15
421Vt-S1E		4	1/15	4.0	240	4.3	15
524Vt-S1E		5	1/15	5.0	300	5.3	15
627Vt-S1E		6	1/15	6.0	360	6.3	15

# = A, H or R. Refer to nomenclature for details.  
 \* = H or R Available on 2 to 6 fan models only.  
 † = H or R Refer to nomenclature for details.

## 208-230/1/60: Air Defrost &amp; Hot Gas Defrost with Hot Gas Loop Pan Models

Model KLP	FPI	FAN MOTORS					
		Qty.	Standard SMARTSPEED <sup>®</sup> EC Motors				
			HP	FLA Total	Watts	MCA (A)	MOP (A)
105MA-S2E *	6	1	1/15	0.6	60	0.8	15
107MA-S2E *		1	1/15	0.6	60	0.8	15
108MA-S2E *		1	1/15	0.6	60	0.8	15
210M#-S2E		2	1/15	1.2	120	1.4	15
212M#-S2E		2	1/15	1.2	120	1.4	15
215M#-S2E		2	1/15	1.2	120	1.4	15
318M#-S2E		3	1/15	1.8	180	2.0	15
322M#-S2E		3	1/15	1.8	180	2.0	15
424M#-S2E		4	1/15	2.4	240	2.6	15
429M#-S2E		4	1/15	2.4	240	2.6	15
537M#-S2E		5	1/15	3.0	300	3.2	15
644M#-S2E		6	1/15	3.6	360	3.8	15
104Lt-S2E	6	1	1/15	0.6	60	0.8	15
105Lt-S2E		1	1/15	0.6	60	0.8	15
106Lt-S2E		1	1/15	0.6	60	0.8	15
207Lt-S2E		2	1/15	1.2	120	1.4	15
209Lt-S2E		2	1/15	1.2	120	1.4	15
211Lt-S2E		2	1/15	1.2	120	1.4	15
314Lt-S2E		3	1/15	1.8	180	2.0	15
316Lt-S2E		3	1/15	1.8	180	2.0	15
418Lt-S2E		4	1/15	2.4	240	2.6	15
421Lt-S2E		4	1/15	2.4	240	2.6	15
526Lt-S2E		5	1/15	3.0	300	3.2	15
631Lt-S2E		6	1/15	3.6	360	3.8	15
103Vt-S2E	4	1	1/15	0.6	60	0.8	15
104Vt-S2E		1	1/15	0.6	60	0.8	15
106Vt-S2E		1	1/15	0.6	60	0.8	15
207Vt-S2E		2	1/15	1.2	120	1.4	15
208Vt-S2E		2	1/15	1.2	120	1.4	15
211Vt-S2E		2	1/15	1.2	120	1.4	15
313Vt-S2E		3	1/15	1.8	180	2.0	15
316Vt-S2E		3	1/15	1.8	180	2.0	15
418Vt-S2E		4	1/15	2.4	240	2.6	15
421Vt-S2E		4	1/15	2.4	240	2.6	15
524Vt-S2E		5	1/15	3.0	300	3.2	15
627Vt-S2E		6	1/15	3.6	360	3.8	15

# = A, H or R. Refer to nomenclature for details.

\* = H or R Available on 2 to 6 fan models only.

† = H or R Refer to nomenclature for details.

208-230/1/60 & 208-230/3/60: Electric Defrost Models

Model KLP	FPI	FAN MOTORS					DEFROST HEATERS							
		Qty.	Standard SMARTSPEED <sup>®</sup> EC Motors					Total WATTS	208-230/1/60			208-230/3/60		
			HP	FLA Total	Watts	MCA (A)	MOP (A)		Total AMPS	MCA (A)	MOP (A)	Total AMPS	MCA (A)	MOP (A)
105ME-*	6	1	1/15	0.6	60	0.8	15	1060	4.6	5.8	15	3.0	3.8	15
107ME-*		1	1/15	0.6	60	0.8	15	1060	4.6	5.8	15	3.0	3.8	15
108ME-*		1	1/15	0.6	60	0.8	15	1060	4.6	5.8	15	3.0	3.8	15
210ME-*		2	1/15	1.2	120	1.4	15	1890	8.2	10.3	15	5.3	6.7	15
212ME-*		2	1/15	1.2	120	1.4	15	1890	8.2	10.3	15	5.3	6.7	15
215ME-*		2	1/15	1.2	120	1.4	15	1890	8.2	10.3	15	5.3	6.7	15
318ME-*		3	1/15	1.8	180	2.0	15	2730	11.9	14.8	15	7.7	10.0	15
322ME-*		3	1/15	1.8	180	2.0	15	2730	11.9	14.8	15	7.7	10.0	15
424ME-*		4	1/15	2.4	240	2.6	15	3560	15.5	19.3	20	10.0	12.0	15
429ME-*		4	1/15	2.4	240	2.6	15	3560	15.5	19.3	20	10.0	12.0	15
537ME-*		5	1/15	3.0	300	3.2	15	4400	19.1	23.9	25	12.0	15.0	20
644ME-*		6	1/15	3.6	360	3.8	15	5230	22.7	28.4	30	15.0	18.0	20
104LE-*	6	1	1/15	0.6	60	0.8	15	1060	4.6	5.8	15	3.0	3.8	15
105LE-*		1	1/15	0.6	60	0.8	15	1060	4.6	5.8	15	3.0	3.8	15
106LE-*		1	1/15	0.6	60	0.8	15	1060	4.6	5.8	15	3.0	3.8	15
207LE-*		2	1/15	1.2	120	1.4	15	1890	8.2	10.3	15	5.3	6.7	15
209LE-*		2	1/15	1.2	120	1.4	15	1890	8.2	10.3	15	5.3	6.7	15
211LE-*		2	1/15	1.2	120	1.4	15	1890	8.2	10.3	15	5.3	6.7	15
314LE-*		3	1/15	1.8	180	2.0	15	2730	11.9	14.8	15	7.7	10.0	15
316LE-*		3	1/15	1.8	180	2.0	15	2730	11.9	14.8	15	7.7	10.0	15
418LE-*		4	1/15	2.4	240	2.6	15	3560	15.5	19.3	20	10.0	12.0	15
421LE-*		4	1/15	2.4	240	2.6	15	3560	15.5	19.3	20	10.0	12.0	15
526LE-*		5	1/15	3.0	300	3.2	15	4400	19.1	23.9	25	12.0	15.0	20
631LE-*		6	1/15	3.6	360	3.8	15	5230	22.7	28.4	30	15.0	18.0	20
103VE-*	4	1	1/15	0.6	60	0.8	15	1060	4.6	5.8	15	3.0	3.8	15
104VE-*		1	1/15	0.6	60	0.8	15	1060	4.6	5.8	15	3.0	3.8	15
106VE-*		1	1/15	0.6	60	0.8	15	1060	4.6	5.8	15	3.0	3.8	15
207VE-*		2	1/15	1.2	120	1.4	15	1890	8.2	10.3	15	5.3	6.7	15
208VE-*		2	1/15	1.2	120	1.4	15	1890	8.2	10.3	15	5.3	6.7	15
211VE-*		2	1/15	1.2	120	1.4	15	1890	8.2	10.3	15	5.3	6.7	15
313VE-*		3	1/15	1.8	180	2.0	15	2730	11.9	14.8	15	7.7	10.0	15
316VE-*		3	1/15	1.8	180	2.0	15	2730	11.9	14.8	15	7.7	10.0	15
418VE-*		4	1/15	2.4	240	2.6	15	3560	15.5	19.3	20	10.0	12.0	15
421VE-*		4	1/15	2.4	240	2.6	15	3560	15.5	19.3	20	10.0	12.0	15
524VE-*		5	1/15	3.0	300	3.2	15	4400	19.1	23.9	25	12.0	15.0	20
627VE-*		6	1/15	3.6	360	3.8	15	5230	22.7	28.4	30	15.0	18.0	20

\* = S2 or T3. Refer to nomenclature for details.

## 115/1/60: Hot Gas Defrost with Drain Pan Heater Models

Model KLP	FPI	FAN MOTORS						DRAIN PAN HEATERS			
		Qty.	Standard SMARTSPEED <sup>®</sup> EC Motors					Total WATTS	Total AMPS	MCA (A)	MOP (A)
			HP	FLA Total	Watts	MCA (A)	MOP (A)				
210M#-S1E	6	2	1/15	1.2	120	1.4	15	410	3.6	4.5	15
212M#-S1E		2	1/15	1.2	120	1.4	15	410	3.6	4.5	15
215M#-S1E		2	1/15	1.2	120	1.4	15	410	3.6	4.5	15
318M#-S1E		3	1/15	1.8	180	2.0	15	560	4.9	6.1	15
322M#-S1E		3	1/15	1.8	180	2.0	15	560	4.9	6.1	15
424M#-S1E		4	1/15	2.4	240	2.6	15	720	6.3	7.8	15
429M#-S1E		4	1/15	2.4	240	2.6	15	720	6.3	7.8	15
537M#-S1E		5	1/15	3.0	300	3.2	15	880	7.7	9.6	15
644M#-S1E		6	1/15	3.6	360	3.8	15	1030	9.0	11.2	15
207L#-S1E	6	2	1/15	1.2	120	1.4	15	410	3.6	4.5	15
209L#-S1E		2	1/15	1.2	120	1.4	15	410	3.6	4.5	15
211L#-S1E		2	1/15	1.2	120	1.4	15	410	3.6	4.5	15
314L#-S1E		3	1/15	1.8	180	2.0	15	560	4.9	6.1	15
316L#-S1E		3	1/15	1.8	180	2.0	15	560	4.9	6.1	15
418L#-S1E		4	1/15	2.4	240	2.6	15	720	6.3	7.8	15
421L#-S1E		4	1/15	2.4	240	2.6	15	720	6.3	7.8	15
526L#-S1E		5	1/15	3.0	300	3.2	15	880	7.7	9.6	15
631L#-S1E		6	1/15	3.6	360	3.8	15	1030	9.0	11.2	15
207V#-S1E	4	2	1/15	1.2	120	1.4	15	410	3.6	4.5	15
208V#-S1E		2	1/15	1.2	120	1.4	15	410	3.6	4.5	15
211V#-S1E		2	1/15	1.2	120	1.4	15	410	3.6	4.5	15
313V#-S1E		3	1/15	1.8	180	2.0	15	560	4.9	6.1	15
316V#-S1E		3	1/15	1.8	180	2.0	15	560	4.9	6.1	15
418V#-S1E		4	1/15	2.4	240	2.6	15	720	6.3	7.8	15
421V#-S1E		4	1/15	2.4	240	2.6	15	720	6.3	7.8	15
524V#-S1E		5	1/15	3.0	300	3.2	15	880	7.7	9.6	15
627V#-S1E		6	1/15	3.6	360	3.8	15	1030	9.0	11.2	15

# = T or G. Refer to nomenclature for details.

208-230/1/60: Hot Gas Defrost with Drain Pan Heater Models

Model KLP	FPI	FAN MOTORS					DRAIN PAN HEATERS				
		Qty.	Standard SMARTSPEED <sup>®</sup> EC Motors					Total WATTS	Total AMPS	MCA (A)	MOP (A)
			HP	FLA Total	Watts	MCA (A)	MOP (A)				
210M <sup>^</sup> -S2E	6	2	1/15	1.2	120	1.4	15	410	1.8	2.2	15
212M <sup>^</sup> -S2E		2	1/15	1.2	120	1.4	15	410	1.8	2.2	15
215M <sup>^</sup> -S2E		2	1/15	1.2	120	1.4	15	410	1.8	2.2	15
318M <sup>^</sup> -S2E		3	1/15	1.8	180	2.0	15	560	2.4	3.0	15
322M <sup>^</sup> -S2E		3	1/15	1.8	180	2.0	15	560	2.4	3.0	15
424M <sup>^</sup> -S2E		4	1/15	2.4	240	2.6	15	720	3.1	3.9	15
429M <sup>^</sup> -S2E		4	1/15	2.4	240	2.6	15	720	3.1	3.9	15
537M <sup>^</sup> -S2E		5	1/15	3.0	300	3.2	15	880	3.8	4.8	15
644M <sup>^</sup> -S2E		6	1/15	3.6	360	3.8	15	1030	4.0	5.0	15
207L <sup>^</sup> -S2E		6	2	1/15	1.2	120	1.4	15	410	1.8	2.2
209L <sup>^</sup> -S2E	2		1/15	1.2	120	1.4	15	410	1.8	2.2	15
211L <sup>^</sup> -S2E	2		1/15	1.2	120	1.4	15	410	1.8	2.2	15
314L <sup>^</sup> -S2E	3		1/15	1.8	180	2.0	15	560	2.4	3.0	15
316L <sup>^</sup> -S2E	3		1/15	1.8	180	2.0	15	560	2.4	3.0	15
418L <sup>^</sup> -S2E	4		1/15	2.4	240	2.6	15	720	3.1	3.9	15
421L <sup>^</sup> -S2E	4		1/15	2.4	240	2.6	15	720	3.1	3.9	15
526L <sup>^</sup> -S2E	5		1/15	3.0	300	3.2	15	880	3.8	4.8	15
631L <sup>^</sup> -S2E	6		1/15	3.6	360	3.8	15	1030	4.0	5.0	15
207V <sup>^</sup> -S2E	4		2	1/15	1.2	120	1.4	15	410	1.8	2.2
208V <sup>^</sup> -S2E		2	1/15	1.2	120	1.4	15	410	1.8	2.2	15
211V <sup>^</sup> -S2E		2	1/15	1.2	120	1.4	15	410	1.8	2.2	15
313V <sup>^</sup> -S2E		3	1/15	1.8	180	2.0	15	560	2.4	3.0	15
316V <sup>^</sup> -S2E		3	1/15	1.8	180	2.0	15	560	2.4	3.0	15
418V <sup>^</sup> -S2E		4	1/15	2.4	240	2.6	15	720	3.1	3.9	15
421V <sup>^</sup> -S2E		4	1/15	2.4	240	2.6	15	720	3.1	3.9	15
524V <sup>^</sup> -S2E		5	1/15	3.0	300	3.2	15	880	3.8	4.8	15
627V <sup>^</sup> -S2E		6	1/15	3.6	360	3.8	15	1030	4.0	5.0	15

<sup>^</sup> = T or G. Refer to nomenclature for details.

**208-230/1/60: Electrical Defrost  
W/ ESP **

Model KLP	FPI	ESP+ CIRCUIT	
		208-230/1/60	
		MCA (A)	MOP (A)
105ME-S2E	6	5.8	15
107ME-S2E		5.8	15
108ME-S2E		5.8	15
210ME-S2E		10.3	15
212ME-S2E		10.3	15
215ME-S2E		10.3	15
318ME-S2E		14.8	15
322ME-S2E		14.8	15
424ME-S2E		19.3	20
429ME-S2E		19.3	20
537ME-S2E		23.9	25
644ME-S2E		28.4	30
104LE-S2E		6	5.8
105LE-S2E	5.8		15
106LE-S2E	5.8		15
207LE-S2E	10.3		15
209LE-S2E	10.3		15
211LE-S2E	10.3		15
314LE-S2E	14.8		15
316LE-S2E	14.8		15
418LE-S2E	19.3		20
421LE-S2E	19.3		20
526LE-S2E	23.9		25
631LE-S2E	28.4		30
103VE-S2E	4		5.8
104VE-S2E		5.8	15
106VE-S2E		5.8	15
207VE-S2E		10.3	15
208VE-S2E		10.3	15
211VE-S2E		10.3	15
313VE-S2E		14.8	15
316VE-S2E		14.8	15
418VE-S2E		19.3	20
421VE-S2E		19.3	20
524VE-S2E		23.9	25
627VE-S2E		28.4	30

**208-230/3/60: Electrical Defrost  
W/ ESP **

Model KLP	FPI	ESP+ CIRCUIT	
		208-230/3/60	
		MCA (A)	MOP (A)
105ME-T3E	6	3.8	15
107ME-T3E		3.8	15
108ME-T3E		3.8	15
210ME-T3E		6.7	15
212ME-T3E		6.7	15
215ME-T3E		6.7	15
318ME-T3E		9.6	15
322ME-T3E		9.6	15
424ME-T3E		12.5	15
429ME-T3E		12.5	15
537ME-T3E		15.4	20
644ME-T3E		18.3	20
104LE-T3E		6	3.8
105LE-T3E	3.8		15
106LE-T3E	3.8		15
207LE-T3E	6.7		15
209LE-T3E	6.7		15
211LE-T3E	6.7		15
314LE-T3E	9.6		15
316LE-T3E	9.6		15
418LE-T3E	12.5		15
421LE-T3E	12.5		15
526LE-T3E	15.4		20
631LE-T3E	18.3		20
103VE-T3E	4		3.8
104VE-T3E		3.8	15
106VE-T3E		3.8	15
207VE-T3E		6.7	15
208VE-T3E		6.7	15
211VE-T3E		6.7	15
313VE-T3E		9.6	15
316VE-T3E		9.6	15
418VE-T3E		12.5	15
421VE-T3E		12.5	15
524VE-T3E		15.4	20
627VE-T3E		18.3	20

## ESP+ INTUITIVE EVAPORATOR CONTROL TECHNOLOGY

### What is ESP+?

KeepRite Refrigeration's ESP+ intuitive evaporator control technology is designed to replace traditional electro-mechanical refrigeration controls typically used on medium and low temperature applications. By combining award winning adaptive technology along with an electronic expansion valve, KeepRite Refrigeration continues to be The Right Choice For The Refrigeration Professional.

Installing an evaporator utilizing the ESP+ intuitive evaporator control technology is simple. Two pipes, two wires and you're done. No interconnecting control wiring between the evaporator and the condensing unit is required.

- Quick, simple installation
- Improved evaporator performance by minimizing excessive frost on the evaporator
  - Eliminates ice build up on surfaces and product
  - Energy savings through evaporator fan management
  - Energy savings with reduction in the number of defrost cycles
    - Defrost heater management
- Improved system diagnostics and service through advanced alarm notification text/email
  - Remote monitoring & system control
    - User friendly interface
  - Precise temperature control for prolonged product shelf life
  - Improved product integrity with less potential for spoilage
  - Downloadable data provides system history for prior 30 days
  - Remotely view and change system parameters and alarm settings
    - Manually control system
    - Easily troubleshoot issues
  - Refrigerant Leak Mitigation Strategy Included for A2L units

### ESP+ controls:

- Box Temperature
- Superheat
- Liquid Line Solenoid
- Defrost Initiation
- Defrost Termination
- Fan Motors
- Defrost Heater (Electric Defrost Models)

*Plus - User can access operating data directly from the system interface*

## 15-20% System Energy Savings over a Properly Commissioned System!

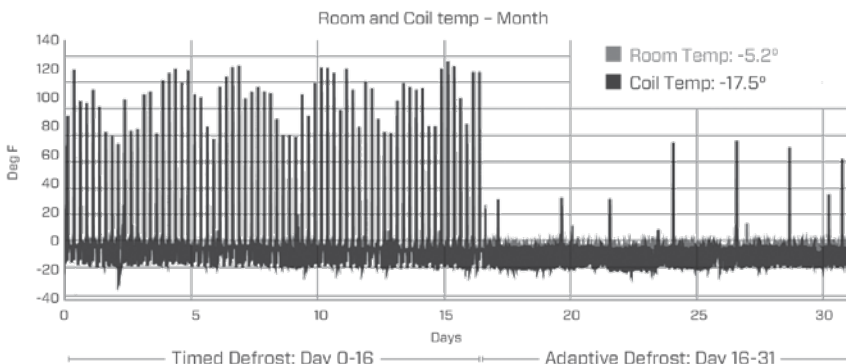

### 86% Fewer Defrost Cycles\*

- Enhanced system performance
- Energy Savings
- Improved product integrity

\* Data may vary depending on application

Visit [www.k-rp.com/esp](http://www.k-rp.com/esp) for details











**Annual Walk-In Energy Factor Ratings - High/Medium Temperature**

If a numerical value is listed in the table below, the following statement applies to that corresponding model: "This refrigeration system is designed and certified for use in walk-in cooler applications."

Model KLP	R454A	R454C	R455A
105M	9.00	9.00	9.00
107M	9.00	9.00	9.00
108M	9.00	9.00	9.00
210M	9.00	9.00	9.00
212M	9.00	9.00	9.00
215M	9.00	9.00	9.00
318M	9.00	9.00	9.00
322M	9.00	9.00	9.00
424M	9.00	9.00	9.00
429M	9.00	9.00	9.00
537M	9.00	9.00	9.00
644M	9.00	9.00	9.00

**Annual Walk-In Energy Factor Ratings - Low Temperature**

If a numerical value is listed in the table below, the following statement applies to that corresponding model: "This refrigeration system is designed and certified for use in walk-in freezer applications."

Model KLP	R454A	R454C	R455A
104L	3.96	3.96	3.96
105L	3.97	3.97	3.97
106L	3.99	3.99	3.99
207L	3.99	3.99	3.99
209L	4.02	4.02	4.02
211L	4.04	4.04	4.04
314L	4.07	4.07	4.07
316L	4.10	4.10	4.10
418L	4.13	4.13	4.13
421L	4.15	4.15	4.15
526L	4.15	4.15	4.15
631L	4.15	4.15	4.15

Model KLP	R454A	R454C	R455A
103V	3.95	3.95	3.95
104V	3.96	3.96	3.96
106V	3.98	3.98	3.98
207V	3.99	3.99	3.99
208V	4.01	4.01	4.01
211V	4.04	4.04	4.04
313V	4.06	4.06	4.06
316V	4.10	4.10	4.10
418V	4.13	4.13	4.13
421V	4.15	4.15	4.15
524V	4.15	4.15	4.15
627V	4.15	4.15	4.15

**Sound Data**

dBa @ 10 ft.

GEN E	1 FAN	2 FAN	3 Fan	4 Fan	5 Fan	6 Fan
	54	55.9	57	58	58.5	59

Data is Typical of "Free Field" conditions. Factors such as reflecting walls, background noises and installation may have significant influence on data.  
Data above is for reference only.

# DIMENSIONAL DATA / SPECIFICATIONS

# KLP - LOW PROFILE EVAPORATORS

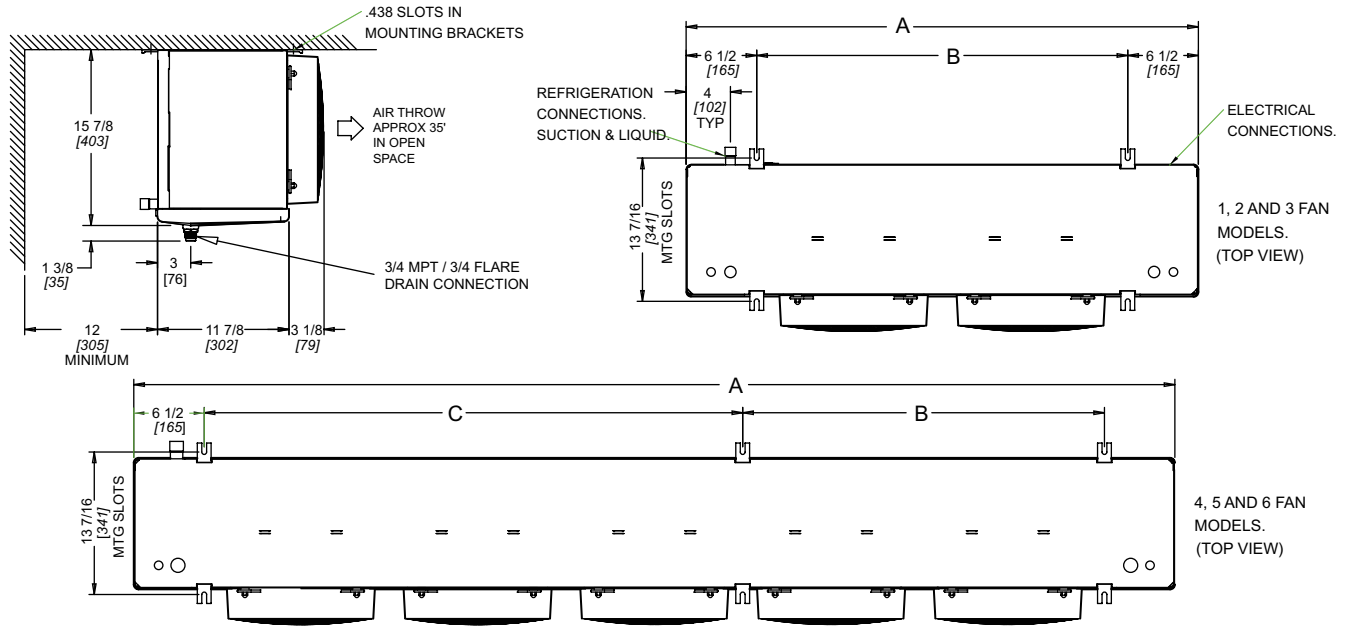

MODEL KLP	NO. OF FANS	A		B		C		SUCTION CONNECTION (ID) SWEAT	DISTRIBUTOR INLET SIZE	HOT GAS DIS- TRIBUTOR SIDE PORT	DRAIN PAN LOOP
		IN	mm	IN	mm	IN	mm				
105M^	1	30 1/4	768	17 1/4	438	N/A	N/A	5/8	1/2	1/2	N/A
107M^		30 1/4	768	17 1/4	438	N/A	N/A	5/8	1/2	1/2	N/A
108M^		30 1/4	768	17 1/4	438	N/A	N/A	5/8	1/2	1/2	N/A
210M#	2	46 1/4	1175	33 1/4	845	N/A	N/A	7/8	1/2	1/2	5/8
212M#		46 1/4	1175	33 1/4	845	N/A	N/A	7/8	1/2	1/2	5/8
215M#		46 1/4	1175	33 1/4	845	N/A	N/A	7/8	1/2	1/2	5/8
318M#	3	62 1/4	1581	49 1/4	1251	N/A	N/A	7/8	1/2	1/2	7/8
322M#		62 1/4	1581	49 1/4	1251	N/A	N/A	7/8	1/2	1/2	7/8
424M#	4	78 1/4	1988	32 5/8	829	32 5/8	829	1 1/8	1/2	1/2	7/8
429M#		78 1/4	1988	32 5/8	829	32 5/8	829	1 1/8	1/2	1/2	7/8
537M#	5	94 1/4	2394	32 5/8	829	48 5/8	1235	1 3/8	1/2	1/2	1 1/8
644M#	6	110 1/4	2800	48 5/8	1235	48 5/8	1235	1 3/8	7/8	5/8	1 1/8
104L^	1	30 1/4	768	17 1/4	438	N/A	N/A	5/8	1/2	1/2	N/A
105L^		30 1/4	768	17 1/4	438	N/A	N/A	5/8	1/2	1/2	N/A
106L^		30 1/4	768	17 1/4	438	N/A	N/A	5/8	1/2	1/2	N/A
207L#	2	46 1/4	1175	33 1/4	845	N/A	N/A	7/8	1/2	1/2	5/8
209L#		46 1/4	1175	33 1/4	845	N/A	N/A	7/8	1/2	1/2	5/8
211L#		46 1/4	1175	33 1/4	845	N/A	N/A	7/8	1/2	1/2	5/8
314L#	3	62 1/4	1581	49 1/4	1251	N/A	N/A	7/8	1/2	1/2	7/8
316L#		62 1/4	1581	49 1/4	1251	N/A	N/A	1 1/8	1/2	1/2	7/8
418L#	4	78 1/4	1988	32 5/8	829	32 5/8	829	1 1/8	1/2	1/2	7/8
421L#		78 1/4	1988	32 5/8	829	32 5/8	829	1 1/8	7/8	5/8	7/8
526L#	5	94 1/4	2394	32 5/8	829	48 5/8	1235	1 3/8	7/8	5/8	1 1/8
631L#	6	110 1/4	2800	48 5/8	1235	48 5/8	1235	1 3/8	7/8	5/8	1 1/8
103V^	1	30 1/4	768	17 1/4	438	N/A	N/A	5/8	1/2	1/2	N/A
104V^		30 1/4	768	17 1/4	438	N/A	N/A	5/8	1/2	1/2	N/A
106V^		30 1/4	768	17 1/4	438	N/A	N/A	5/8	1/2	1/2	N/A
207V#	2	46 1/4	1175	33 1/4	845	N/A	N/A	7/8	1/2	1/2	5/8
208V#		46 1/4	1175	33 1/4	845	N/A	N/A	7/8	1/2	1/2	5/8
211V#		46 1/4	1175	33 1/4	845	N/A	N/A	7/8	1/2	1/2	5/8
313V#	3	62 1/4	1581	49 1/4	1251	N/A	N/A	7/8	1/2	1/2	7/8
316V#		62 1/4	1581	49 1/4	1251	N/A	N/A	1 1/8	1/2	1/2	7/8
418V#	4	78 1/4	1988	32 5/8	829	32 5/8	829	1 1/8	1/2	1/2	7/8
421V#		78 1/4	1988	32 5/8	829	32 5/8	829	1 1/8	7/8	5/8	7/8
524V#	5	94 1/4	2394	32 5/8	829	48 5/8	1235	1 3/8	7/8	5/8	1 1/8
627V#	6	110 1/4	2800	48 5/8	1235	48 5/8	1235	1 3/8	7/8	5/8	1 1/8

# = A, E, T, H, G, or R. ^ = A or E. T, H, G or R available in 2 to 6 fan models only Refer to Nomenclature for details

**Air Defrost and Hot Gas Defrost with Drain Pan Heater Models**

MODEL KLP							SHIPPING WEIGHT	
							LB.	kg
105MA	N/A	N/A	N/A	N/A	N/A	N/A	45	20
107MA							N/A	N/A
108MA							49	22
210MA	210MT	210MG	207LG	207LT	207VG	207VT	70	32
212MA	212MT	212MG	209LG	209LT	208VG	208VT	74	33
215MA	215MT	215MG	211LG	211LT	211VG	211VT	78	35
318MA	318MT	318MG	314LG	314LT	313VG	313VT	101	46
322MA	322MT	322MG	316LG	316LT	316VG	316VT	107	48
424MA	424MT	424MG	418LG	418LT	418VG	418VT	117	53
429MA	429MT	429MG	421LG	421LT	421VG	421VT	135	61
537MA	537MT	537MG	526LG	526LT	524VG	524VT	163	74
644MA	644MT	644MG	631LG	631LT	627VG	627VT	192	87

**Electric Defrost Models**

MODEL KLP			SHIPPING WEIGHT	
			LB.	kg
105ME	104LE	103VE	49	22
107ME	105LE	104VE	51	23
108ME	106LE	106VE	53	24
210ME	207LE	207VE	76	35
212ME	209LE	208VE	80	36
215ME	211LE	211VE	84	38
318ME	314LE	313VE	109	49
322ME	316LE	316VE	115	52
424ME	418LE	418VE	127	58
429ME	421LE	421VE	145	66
537ME	526LE	524VE	176	80
644ME	631LE	627VE	207	94

**Hot Gas Defrost with Drain Pan Loop Models**

MODEL KLP						SHIPPING WEIGHT	
						LB.	kg
210MH	210MR	207LH	207LR	207VH	207VR	87	39
212MH	212MR	209LH	209LR	208VH	208VR	91	41
215MH	215MR	211LH	211LR	211VH	211VR	95	43
318MH	318MR	314LH	314LR	313VH	313VR	124	56
322MH	322MR	316LH	316LR	316VH	316VR	130	59
424MH	424MR	418LH	418LR	418VH	418VR	145	66
429MH	429MR	421LH	421LR	421VH	421VR	163	74
537MH	537MR	526LH	526LR	524VH	524VR	198	90
644MH	644MR	631LH	631LR	627VH	627VR	233	106

**Models with ESP **

**Medium Temperature Air Or Electric Defrost  
All Refrigerants**

MODEL KLP	FACTORY INSTALLED NOZZLE	PRIMARY INSTALLED ELECTRONIC EXPANSION VALVE	ALTERNATE INSTALLED ELECTRONIC EXPANSION VALVE	FACTORY INSTALLED LIQUID LINE SOLENOID VALVE	FOR E-GEN A2L UNITS	
					FACTORY SUPPLIED SAFETY SOLENOID VALVE	FACTORY SUPPLIED SAFETY CHECK VALVE
105M***	N/A	RSV 220	E2V24	E3	SSOV3	CSOV5
107M***	L1/2	RSV 220	E2V24	E3	SSOV3	CSOV5
108M***	L1/2	RSV 220	E2V24	E3	SSOV3	CSOV5
210M***	L3/4	RSV 220	E2V24	E3	SSOV3	CSOV7
212M***	L1	RSV 220	E2V24	E3	SSOV3	CSOV7
215M***	L1	RSV 220	E2V24	E3	SSOV3	CSOV7
318M***	L1-1/2	RSV 220	E2V24	E5	SSOV6	CSOV7
322M***	L1-1/2	RSV 220	E2V24	E5	SSOV6	CSOV7
424M***	L2	RSV 320	E2V24	E5	SSOV6	CSOV9
429M***	L2	RSV 320	E2V24	E5	SSOV6	CSOV9
537M***	L2-1/2	RSV 320	E2V35	E6	SSOV6	CSOV11
644M***	G3	E2V35	RSV 400	E6	SSOV6	CSOV11

\*\*\* Insert Air or Electric Defrost type. See nomenclature for details.  
ESP+ not available on Hot Gas Defrost models

**Low Temperature Electric Defrost 6 FPI  
All Refrigerants**

MODEL KLP	FACTORY INSTALLED NOZZLE	PRIMARY INSTALLED ELECTRONIC EXPANSION VALVE	ALTERNATE INSTALLED ELECTRONIC EXPANSION VALVE	FACTORY INSTALLED LIQUID LINE SOLENOID VALVE	FOR E-GEN A2L UNITS	
					FACTORY SUPPLIED SAFETY SOLENOID VALVE	FACTORY SUPPLIED SAFETY CHECK VALVE
104LE	L1/2	E2V24	RSV220	E3	SSOV3	CSOV5
105LE	L3/4	E2V24	RSV220	E3	SSOV3	CSOV5
106LE	L1	E2V24	RSV220	E3	SSOV3	CSOV5
207LE	L1	E2V24	RSV220	E3	SSOV3	CSOV7
209LE	L1-1/2	E2V24	RSV220	E3	SSOV3	CSOV7
211LE	L2	E2V24	RSV220	E3	SSOV3	CSOV7
314LE	L2	E2V24	RSV220	E5	SSOV6	CSOV7
316LE	L3	E2V24	RSV220	E5	SSOV6	CSOV9
418LE	L3	E2V24	RSV220	E5	SSOV6	CSOV9
421LE	G4	E2V35	RSV220	E5	SSOV6	CSOV9
526LE	G4	E2V35	RSV320	E6	SSOV6	CSOV11
631LE	G5	E2V35	RSV320	E6	SSOV6	CSOV11

**Low Temperature Electric Defrost 4 FPI  
All Refrigerants**

MODEL KLP	FACTORY INSTALLED NOZZLE	PRIMARY INSTALLED ELECTRONIC EXPANSION VALVE	ALTERNATE INSTALLED ELECTRONIC EXPANSION VALVE	FACTORY INSTALLED LIQUID LINE SOLENOID VALVE	FOR E-GEN A2L UNITS	
					FACTORY SUPPLIED SAFETY SOLENOID VALVE	FACTORY SUPPLIED SAFETY CHECK VALVE
103VE	L1/2	E2V24	RSV220	E3	SSOV3	CSOV5
104VE	L3/4	E2V24	RSV220	E3	SSOV3	CSOV5
106VE	L1	E2V24	RSV220	E3	SSOV3	CSOV5
207VE	L1	E2V24	RSV220	E3	SSOV3	CSOV7
208VE	L1-1/2	E2V24	RSV220	E3	SSOV3	CSOV7
211VE	L2	E2V24	RSV220	E3	SSOV3	CSOV7
313VE	L2	E2V24	RSV220	E5	SSOV3	CSOV7
316VE	L2-1/2	E2V24	RSV220	E5	SSOV6	CSOV9
418VE	J2-1/2	E2V24	RSV220	E5	SSOV6	CSOV9
421VE	G3	E2V35	RSV220	E5	SSOV6	CSOV9
524VE	G4	E2V35	RSV220	E6	SSOV6	CSOV11
627VE	G5	E2V35	RSV320	E6	SSOV6	CSOV11

## INSTALLATION

The installation and start-up of evaporators should only be performed by qualified refrigeration mechanics. This equipment should be installed in accordance with all applicable codes, ordinances and local by-laws.

## INSPECTION

Inspect all equipment before unpacking for visible signs of damage or loss. Check shipping list against material received to ensure shipment is complete.

**IMPORTANT:** Remember, you, the consignee, must make any claim necessary against the transportation company. Shipping damage or missing parts, when discovered at the outset, will prevent later unnecessary and costly delays.

**If damage or loss during transport is evident, make claim to carrier, as this will be their responsibility, not the manufacturer's.**

Should carton be damaged, but damage to equipment is not obvious, a claim should be filed for "concealed damage" with the carrier.

**IMPORTANT:** The electrical characteristics of the unit should be checked at this time to make sure they correspond to those ordered and to electrical power available at the job site.

Save all shipping papers, tags and instruction sheets for reference by installer and owner.

## APPLICATION

LP evaporators are designed for walker-in cooler and freezer applications used with wide range of refrigerants. For room temperatures above 35°F (2 °C) AND evaporating temperatures above 26°F (-3 °C), positive defrosting means (with electric or hot gas) may not be required, otherwise, electric defrost or hot gas defrost models should be used. Electric defrost models come with defrost termination and fan delay as standard to control the defrost cycle termination and fan delay, while defrost initiation means (e.g. defrost timer) is not included.

The coil must not be exposed to any abnormal atmospheric or acidic environments. This may result in corrosion to the cabinet and possible coil failure (leaks). (Consult manufacturer for optional baked on phenolic protective coatings).

## LOCATION

The unit location in the room should be selected to ensure uniform air distribution throughout the entire space to be refrigerated. Be sure that the product does not obstruct the free circulation of air. Allow a minimum of 24" clearance at each end. Do not locate evaporators over doors. Consideration should be given to the coil location in order to minimize the piping run length to the condensing unit and floor drain.

## EXPANSION VALVE (TXV) SELECTION

All units require the use of an externally equalized expansion valve. (A 1/4" (6 mm) O.D. equalizer line has been provided on the coil) TX valves should not be selected strictly by their nominal ton rating. (This rating is based at a specific pressure differential and entering liquid temperature). Since applications will differ it is suggested the following selection procedure be followed.

1. Determine actual evaporator capacity.  
The nominal rating is based at 10°F T.D. (5.6°C) (Entering Air Temp. minus Evap. Temp.) Note that a higher/lower operating T.D. will increase / decrease this capacity rating by their direct ratio within a range of 8 to 12°F (4.4 to 8.3°C) T.D.
2. Determine the pressure drop across the valve by subtracting the evaporating pressure and distributor pressure drop from the high side liquid pressure.  
The distributor pressure drop is typically in the range of 20 to 35 psig (1.4 to 2.4 bar) depending on the type of refrigerant and operating conditions.
3. Estimate entering liquid temperature. Temperatures lower than 100°F (38 °C) increase valve capacity ratings. Refer to valve manufacturer's specs for details.
4. Select valve from the valve manufacturer selection charts for the appropriate refrigerant, evaporating temp and pressure drop.

For best performance, the outlet of the expansion valve should be installed directly to the distributor body. If this is not possible, a straight tube up to 12 inches may be used for the connection.

Locate the expansion valve bulb on a horizontal length of suction line preferably 3 to 6 inches from the suction header. Locate the bulb at 4 or 8 clock position and insulate with a waterproof type of insulation. Clamp the bulb to ensure 100% contact of the bulb with the suction line.

Ensure appropriate nozzle has been installed in the distributor before installing valve. After following the manufacturer's installation instructions and after the room has reached the desired temperature the valve superheat should be checked. This will confirm that the evaporator is operating properly and performing to maximum efficiency. The superheat should be around 6 (3.3 °C) to 8°F (4.4 °C) for a 10 to 12°F T.D (5.6 to 6.7 °C). Too high or low a super heat will result in unsatisfactory system performance and possible compressor problems.

## NOZZLE INSTALLATION

The nozzle for all models has been factory installed. For other applications, refer to nozzle manufacturer's selection guide. To replace a nozzle, the nozzle retainer clip (in distributor) must be removed before inserting nozzle. Re-install clip ensuring nozzle is properly in place. A small nozzle can be drilled larger using the drill size listed in table on page 35. Ensure the hole must be accurately centered and smooth. A lathe is preferred for the drilling.

## MOUNTING

Refer to dimensional drawing for recommended mounting arrangements. Ensure adequate clearance is provided behind the coil as well as each end. The evaporators may be mounted flush with ceiling with bolts, or hanging down with rod hangers. When using rod hangers, allow adequate space between the top of the unit and the ceiling for cleaning to comply with NSF Standard 7.

**Ensure that the ceiling is level since the drain pan has been sloped for drainage during the defrost cycle.**

## DRAIN LINE

The drain line should be run from the drain connection, sloping at least 1" (25 mm) per foot and should have the size at least as large as the drain connection. A trap in a warm area outside the room must be provided to allow proper draining through the tubing. Connection should be made to proper drainage facilities that comply with local regulations.

To prevent freeze-up when the temperature of the refrigerated space is 35°F (2 °C) or lower, the drain line should be heated along its run inside the cold room. The heated drain line should be insulated. It is recommended that the heater be energized at all times. A heat input of 20 watts per foot in a 28°F (-2°C) room and 30 watts per foot for -20°F (-29°C) rooms, is satisfactory. Drain line heaters are not required for constant room temperature above 35°F (2°C).

Always trap evaporator drain line individually to prevent vapor migration.

**Ensure that the drain line has sufficient slope for proper drainage (prevention of ice build up/blockage in pan).**

## PIPING

Refrigeration grade piping must be used for all field refrigeration piping. Refrigerant line sizes are important and may not be the same size as the coil connections. Consult ASHRAE handbook or other similar reference book for proper line sizing.

Refrigerant piping and control system should be designed to prevent possible liquid slugging (from oil or refrigerant) of the compressors on start-up after the defrost cycle. Also, it should prevent oil logging and minimize refrigerant pressure drop.

Hot gas models, refer to pages 44 - 45 for recommended piping.

## WIRING

Wire system in accordance with governing standards and local codes. Refer to data and wiring diagrams on throughout this publication for typical wiring arrangement. Electrical wiring is to be sized in accordance with minimum circuit ampacity rating (MCA). Size fuses used must not exceed the Maximum Fuse Size ratings.

For ease of identifying the proper wiring terminal, unit wiring is color coded and terminal block connections are identified.

When fan delay thermostats (combination fan delay and defrost termination) are installed, on start-up, the fans do not operate until the coil temperature is reduced to approximately 25°F (-4°C). It is normal for the fans to cycle a few times until the room temperature is brought down. At higher evaporating temperatures this control

may not close and therefore should either be by-passed temporarily or replaced with an adjustable type. (set for a higher temperature cut-in point).

## MAINTENANCE

The unit should be periodically inspected for any dirt or ice build-up on the fin surface and cleaned if necessary with a soft whisk or brush. Also ensure coils inner (and outer) drain pans do not have any ice build-up from improper defrost operation. When replacing heater elements first remove heater retainer brackets and heater clips.

## SYSTEM CHECK

### Before Start-Up:

1. All wiring should be in accordance with local codes.
2. Refrigerant lines should be properly sized.
3. All systems preferably include a liquid line solenoid valve at immediately up stream of the expansion valve.
4. Thorough evacuation and dehydration has been performed.
5. The suction, discharge, and receiver service valves must be open.
6. The system preferably include a liquid line filter drier moisture indicator and suction filter.
7. Pour enough water into the drain pan to allow a good check on drainage and seal the trap.

### After Start-Up:

1. Check the oil level to be sure the oil charge is correct.
2. On initial start up the fans do not start until coil temperature is pulled down to approximately 25°F (-4 °C) on the coil. Also, it is normal for the fan to cycle a few times until the room temperature is pulled down.
3. If necessary, temporarily by-pass fan delay control (to run fans until room temp is lowered).
4. Be sure that the expansion valve is properly set to provide the correct amount of superheat.
5. After the box temperature is close to reaching the desired temperature, the evaporator superheat must be checked and adjustment made if necessary. In general, evaporators running with a TD of 10°F (5.6 °C) should have a superheat reading of 6° to 8°F (3.3 °C to 4.4 °C). For evaporators with another T.D., the general rule is that the superheat should be around 60 to 80% of T.D.
6. Heavy moisture loads are usually encountered when starting the system for the first time. This may cause a rapid build-up of frost on the evaporator. During the initial pull down, we suggest that the frost build-up be watched and defrosted manually as required.
7. Observe that the system goes through at least one complete DEFROST CYCLE.



Visit  
**[www.k-rp.com/esp](http://www.k-rp.com/esp)**  
 for Quick Start Guide, Operation Manual, etc

## **WARNING**

Do not use means to accelerate the defrosting process or to clean, other than those recommended by the manufacturer.

The appliance shall be stored or in a room without continuously operating ignition sources (for example: open flames, an operating gas appliance or an operating electric heater).

Do not pierce or burn.

Be aware that refrigerants may not contain an odor.

## **MISE EN GARDE**

Ne pas utiliser de moyens autres que ceux recommandés par le fabricant pour accélérer le processus de dégivrage ou pour nettoyer l'appareil.

L'appareil doit être entreposé dans un local ne contenant pas de sources d'inflammation permanentes (flammes nues, appareil à gaz ou dispositif de chauffage électrique en fonctionnement, par exemple).

Ne pas percer ou brûler.

Attention, les fluides frigorigènes peuvent ne pas dégager d'odeur.

This appliance is not intended for use by persons (including children) with reduced physical, sensory, or mental capabilities, or lack of experience and knowledge, unless they have been given supervision or instruction concerning use of the appliance by a person responsible for their safety. Children should be supervised to ensure that they do not play with the appliance.

This appliance may be installed at an elevation above 6500 ft (2000 m). At higher altitudes, electronic expansion valve controllers may read artificially low superheat due to gauge pressure sensors. Follow the controller manufacturing instructions to calibrate the suction pressure sensor for high altitudes.

Appliance shall be installed in areas not accessible to the general public or at least at a level not less than 99.5" (2.5m).

The evaporator must be wired to a disconnect that breaks all ungrounded conductors. Note that the evaporator may be supplied with a factory installed disconnect.

The evaporator must be connected to a condensing unit designed for the same type of refrigerant.

## **Additional Installation, Service, and Decommissioning requirements for units charged with A2L refrigerants**

### **GENERAL A2L EQUIPMENT SERVICE REQUIREMENTS**

Walk-in cooler or freezer split systems utilizing A2L flammable refrigerants have special requirements for installation, service, and decommissioning. **WARNING:** To reduce flammability hazards, installation and service may only be performed by qualified service personnel who have been licensed by their local and national authorities to perform work on refrigeration systems. Personnel must be trained on how to service equipment utilizing flammable refrigerant, and how to mitigate the hazards. Installation and service may only be performed as recommended by the manufacturer. When making repairs, only service parts recommended by the manufacturer may be used.

When installing, servicing, or decommissioning this equipment, procedures must be used to minimize the risk of flammable gas or vapor being present while the work is being performed. The area must be checked with an appropriate refrigerant detector prior to and during work to ensure that the technician is aware of potentially flammable atmospheres. Refrigerant detection equipment must be designed and sold for use with A2L refrigerants.

### **A2L EQUIPMENT SERVICE PROCEDURE**

All maintenance staff and others working in the local area must be instructed on the nature of the work being performed.

Ensure that no ignition sources are present in the area, including other appliances or cigarette smoking. Prior to work taking place, the area around the equipment shall be surveyed to make sure that there are no flammable hazards or ignition risks. "No Smoking" signs shall be displayed. A dry chemical or CO2 fire extinguisher must be present when any hot work is performed.

Ensure that the area is adequately ventilated before opening the refrigeration system or conducting any hot work. Ventilation must continue for the duration of the work. The ventilation should safely disperse any released refrigerant to the outside atmosphere.

# INSTALLATION INSTRUCTIONS - A2L FOR "E" GENERATION KLP - LOW PROFILE EVAPORATORS

## BEFORE STARTING WORK

- Verify that the markings on the equipment are legible.
- Check that refrigerant containing components and tubing are not excessively corroded or installed in a way that they may become corroded.
- Verify that the releasable charge is appropriate for the room size.
- Test the function of electrical systems, and repair if defective.
- Discharge capacitors in a safe manner to prevent sparking.

## DURING WORK

- No live electrical components and wiring are exposed during charging, recovering, or purging the system.
- Check for continuity of ground bonding.
- Ensure that wires and cables are not subject to wear, corrosion, excess pressure vibration, or sharp edges.
- Do not attempt to repair any sealed electrical component or intrinsically safe component; these must be replaced.

## LEAK DETECTION

When a leak in the refrigerant system is suspected, ensure that all open flames are extinguished. Only a chlorine-free leak detection fluid, or an electronic leak detector designed and sold for use with A2L refrigerants may be used. NEVER USE AN OPEN FLAME TO FIND REFRIGERANT LEAK SOURCES.

If brazing is required to repair a leak, all refrigerant must be recovered from the system or isolated by means of a shutoff valve. The system or the isolated portion of the system must be purged with an inert gas. Ensure that the purging fluid outlet discharges into a well-ventilated area away from any sources of ignition.

## SAFETY ISOLATION VALVES FOR FLAMMABLE REFRIGERANT

Walk-in cooler or freezer split systems utilizing A2L flammable refrigerant must be equipped with safety isolation valves to limit the releasable charge in the event of a leak. These safety isolation valves may be either factory installed in the condensing unit or field installed. Both a liquid line solenoid valve and a suction line check valve are required. Additionally, a discharge line solenoid valve is required for external hot gas bypass or hot gas defrost systems. All safety isolation valves must be installed outside of the walk-in box.

Before proceeding with field installation of refrigerant tubing, verify if the system is equipped with safety isolation valves factory installed in the condensing unit or if they are field installed. Field installed valves must be located outside of the walk-in box.

Field installed safety isolation valves shall be Sporlan SSOV series for liquid and discharge and Sporlan CSOV for suction. Valves must be protected from overheating during installation. Solenoid valves shall be installed to avoid hydraulic shock.

Additional information for applying mitigation valves, including systems with multiple evaporators per condensing unit may be found at the end of this manual.

## FIELD INSTALLED SAFETY SHUTOFF VALVES

The evaporator may be configured with safety shutoff valves for field installation outside of the walk-in box. A check valve is provided for the suction line and a solenoid is provided for the liquid line. If the evaporator is configured with an external hot gas bypass or a hot gas defrost system, a hot gas solenoid is also provided. If the system is configured with reverse cycle defrost, an additional solenoid and check valve are provided for reverse cycle operation.

In the case of multiple evaporators installed in a common refrigeration circuit, each line must be routed outside the walk-in box before being piped together. Safety shutoff valves are provided with each evaporator, which must be installed in the line between the evaporator and the tee.

The solenoid valves are provided with 24VAC coils. The solenoid coils are wired to the terminal strip in the evaporator with 18 AWG class 2 cable or equivalent. All valves and coils are shipped in the end compartment near the refrigerant line connections.

Field installed safety isolation valves should be installed as close to the walk-in box as possible. Ensure that the valves are oriented in the correct flow direction. See drawings for details.

## SAFETY SHUTOFF VALVES FACTORY INSTALLED IN CONDENSING UNIT

The evaporator may be configured to be connected to a condensing unit with factory installed safety shutoff valves. The 24VAC solenoid coil in the condensing unit must be connected to the terminal strip in the evaporator with 18AWG class 2 cable or equivalent.

# INSTALLATION INSTRUCTIONS - A2L FOR "E" GENERATION KLP - LOW PROFILE EVAPORATORS

## MINIMUM WALK-IN BOX AREA



Walk-in cooler or freezer split systems utilizing A2L flammable refrigerant are subject to minimum walk-in box floor area to limit the hazard of a refrigerant leak. This minimum room area depends on the size of the evaporator, as well as the length and diameter of the field installed refrigerant tubing between the evaporator and the safety isolation valves. Follow the instructions below to ensure compliance:

- Measure the distance along the planned tubing route from the outlet of the evaporator to the inlet of the liquid line safety isolation valve.
- Determine the diameter of the liquid and suction lines to be used.
- Measure the internal length and width of the walk-in box. Multiply the length x width to determine the area.
- Find the row with the evaporator model number in the table below. Under the MAXIMUM LINE LENGTH heading, pick the column which is greater than the length of the measured tubing route. Verify that the MINIMUM ROOM AREA value is less than the calculated walk-in box area.
- If the MINIMUM ROOM AREA value is greater than the calculated walk-in box area, or for tubing runs longer than what is shown in the table, contact the factory for guidance.

### Example:

A **KLP212M** evaporator is to be installed in a walk-in cooler.

The length from the outlet of the evaporator to the safety isolation valve is **35 ft (10.6 m)**. Standard **3/8" (10 mm)** liquid line and **7/8" (22 mm)** suction line diameters are used

The internal dimensions of the walk-in box are **12 ft (3.7 m)** wide and **10 ft (3.0 m)** long. The calculated area is **12 ft x 10 ft = 120 ft<sup>2</sup> (3.7 m x 3.0 m = 11.1 m<sup>2</sup>)**.

The **KLP212M** is shown in the fifth row down. The **50 ft (15.2 m)** column shows a minimum room area of **61 ft<sup>2</sup> (5.7 m<sup>2</sup>)**. This is less than the calculated room area, so the installation is compliant.

NOTE: If there are multiple evaporators serving the same walk-in box, each evaporator is connected to its own set field-installed safety shutoff valves. Calculate the releasable charge of each evaporator and use the largest releasable charge to evaluate walk-in box area. Do not add the releasable charges together when evaluating walk-in box area.

	MODEL KLP-			LIQUID LINE OD (mm)	SUCTION LINE OD (mm)	MAXIMUM LINE LENGTH			
						3m	7.6m	15.2m	30.5m
						MINIMUM ROOM AREA (m <sup>2</sup> )			
REFRIGERANT = R454A, R454C, R455A	105M	104L	103V	10	16	2.0	3.0	4.6	-
	107M	105L	104V	10	16	2.3	3.2	4.8	-
	108M	106L	106V	10	16	2.5	3.5	5.1	-
	210M	207L	207V	10	22	2.5	3.5	5.2	8.5
	212M	209L	208V	10	22	3.0	4.0	5.6	9.0
	215M	211L	211V	10	22	3.4	4.4	6.1	9.4
	318M	314L	313V	10	22	3.6	4.6	6.3	9.6
	322M	-	-	10	22	4.2	5.2	6.9	10.3
	-	316L	316V	10	29	4.2	5.2	6.8	10.1
	424M	-	-	13	29	4.9	6.8	10.0	16.4
	-	418L	418V	10	29	4.1	5.1	6.8	10.0
	429M	421L	421V	13	29	5.8	7.7	10.9	17.3
	537M	526L	524V	13	35	6.8	8.8	12.1	18.8
	644M	631L	627V	13	35	7.6	9.6	13.0	19.7

# INSTALLATION INSTRUCTIONS - A2L FOR "E" GENERATION KLP - LOW PROFILE EVAPORATORS

	MODEL KLP			LIQUID LINE OD (in)	SUCTION LINE OD (in)	MAXIMUM LINE LENGTH			
						10 ft	25 ft	50 ft	100 ft
	MINIMUM ROOM AREA (ft <sup>2</sup> )								
REFRIGERANT = R454A, R454C, R455A	105M	104L	103V	3/8	5/8	22	32	49	-
	107M	105L	104V	3/8	5/8	24	35	52	-
	108M	106L	106V	3/8	5/8	27	37	54	-
	210M	207L	207V	3/8	7/8	27	38	56	92
	212M	209L	208V	3/8	7/8	32	43	61	97
	215M	211L	211V	3/8	7/8	37	47	65	101
	318M	314L	313V	3/8	7/8	39	49	67	103
	322M	-	-	3/8	7/8	46	56	74	110
	-	316L	316V	3/8	1 1/8	45	55	73	108
	424M	-	-	1/2	1 1/8	53	73	108	177
	-	418L	418V	3/8	1 1/8	45	55	73	108
	429M	421L	421V	1/2	1 1/8	62	83	117	186
	537M	526L	524V	1/2	1 3/8	73	94	131	203
	644M	631L	627V	1/2	1 3/8	82	103	139	212

## REFRIGERANT TUBING INSTALLATION

Refrigerant piping must be installed in accordance with ANSI/ASHRAE 15 and any other applicable local or national codes.

- All equipment, refrigerant tubing, fittings, and protection devices must be securely mounted and protected from physical damage and other adverse environmental effects such as water collecting and freezing, corrosion, and the accumulation of dirt and debris. Tubing inside the walk-in box or routed through other unventilated spaces must be additionally protected from accidental damage when product or furniture is installed or moved
- All tubing joints must be accessible for inspection prior to being covered or enclosed.
- The routing of tubing must be as direct as possible, and the length of tubing kept to a minimum.
- Use only copper tubing. Flexible connections are not allowed. All field connections must be brazed.
- Provisions shall be made for expansion and contraction of long runs of tubing.
- Tubing shall be installed to minimize damaging effects of hydraulic shock.
- Tubing shall be constrained to prevent excess vibration or pulsation
- Insulation shall be suitable for the material being insulated.
- All installed tubing must be pressure tested to 450 PSIG with an inert gas and held for a minimum of 1 hour with no decrease in pressure. The test gauge must have a minimum resolution of 20 PSIG.
- If the pressure test is successful, the refrigerant piping must be evacuated below 500 microns. After isolating the vacuum pump, the system pressure must remain below 1000 microns for 30 minutes. See "Deep Vacuum Method" in the condensing unit installation manual for more details.

## CHARGING

After installation of field refrigerant tubing, the system must be charged by weight of refrigerant. See the condensing unit installation manual for charging instructions weight for each condensing unit model.

During charging:

- Ensure that contamination of different refrigerants does not occur when using charging equipment. Hoses or lines shall be as short as possible to minimize the amount of refrigerant contained in them.
- Cylinders must be kept in an appropriate position according to the instructions.
- Ensure that the system is earthed prior to charging the system with refrigerant.
- Extreme care shall be taken not to overfill the system.
- After charging, write the refrigerant number and weight in the blank space on the data label of the condensing unit.

After charging, all brazed tubing joints made indoors shall be tested with a refrigerant detector. The detector must have a sensitivity of 0.2 oz/year (5 g/year) or better under a pressure of at least 150 PSIG. No leak shall be detected.

The system must be leak-free before the system is commissioned or recommissioned after repair. See section "REFRIGERANT TUBING INSTALLATION" for additional details on required leak checks.

## REFRIGERANT LEAK MITIGATION SYSTEM

Evaporators designed for A2L refrigerants are equipped with a leak mitigation system to minimize the hazard of refrigerant leaks. The leak mitigation system includes factory installed refrigerant leak sensors, and mitigation controller to initiate mitigation actions in the event of a leak. Mitigation actions include activating fans for circulation, deactivating electric defrost heaters and closing safety isolation valves.

Ventilation of the walk-in box should not be used. Do not connect the evaporator to any ductwork.

Safety isolation solenoid valves must be field wired to the mitigation controller in the evaporator. See unit wiring diagram for additional details.

The mitigation system does not require any periodic maintenance. To test the operation of the mitigation system, disconnect one of the refrigerant leak sensors and verify that the safety isolation solenoid valves close, evaporator fans are energized, and defrost heaters are de-energized.

If a replacement refrigerant leak detector or controller is required, only manufacturer-approved components may be used. Replacement sensors must be installed in the same location as the sensors that were removed.

## REFRIGERANT RECOVERY

Local and national regulations must be followed for recovery, transportation, and disposal of A2L refrigerant. It is essential that best practices are followed to minimize the risk of fire

- All recovery cylinders, recovery machines, vacuum pumps, and other refrigeration tools must be designed for use with A2L refrigerants and must be in good working order, with instruction manuals available for reference.
- Cylinders must be labeled with the refrigerant they contain.
- Ensure that the pressure and rating of the recovery cylinders are appropriate for the refrigerant being recovered. Any pressure relief or overfill prevention devices must be in good working order.
- A calibrated refrigerant scale must be used to measure the weight of the recovered refrigerant to prevent overfilling. Do not fill cylinders more than 80% full.
- Recovery cylinders must be of appropriate volume to contain the refrigerant to be recovered. Multiple recovery cylinders should be available if required.
- Empty cylinders must be evacuated prior to filling.
- Do not mix refrigerants. Recovery machines must be purged before changing refrigerants.
- • All service hose connections must be equipped with a means to limit the release of refrigerant such as anti-blowback fittings or service valves.

After completing all safety checks, safely remove refrigerant according to local and national regulations:

- Recover refrigerant into an appropriate recovery cylinder.
- After achieving the required recovery level, pressurize the system with inert gas to 450 PSIG.
- Safely release the inert gas, ensuring that there are no sources of ignition near the venting outlet.
- If a compressor or compressor oil is going to be removed, the system must be evacuated to ensure that no refrigerant remains dissolved in the oil.
- The system may now be opened by cutting or brazing.

## DECOMMISSIONING

When the system reaches the end of its life, it must be decommissioned. The equipment must be electrically isolated, and all refrigerant must be recovered by competent personnel in accordance with all local and national regulations. See section "REFRIGERANT RECOVERY" for additional details.

The equipment shall be labeled as "DECOMMISSIONED" and marked with the date and signature of the person recovering the refrigerant. The equipment is now ready for disposal.

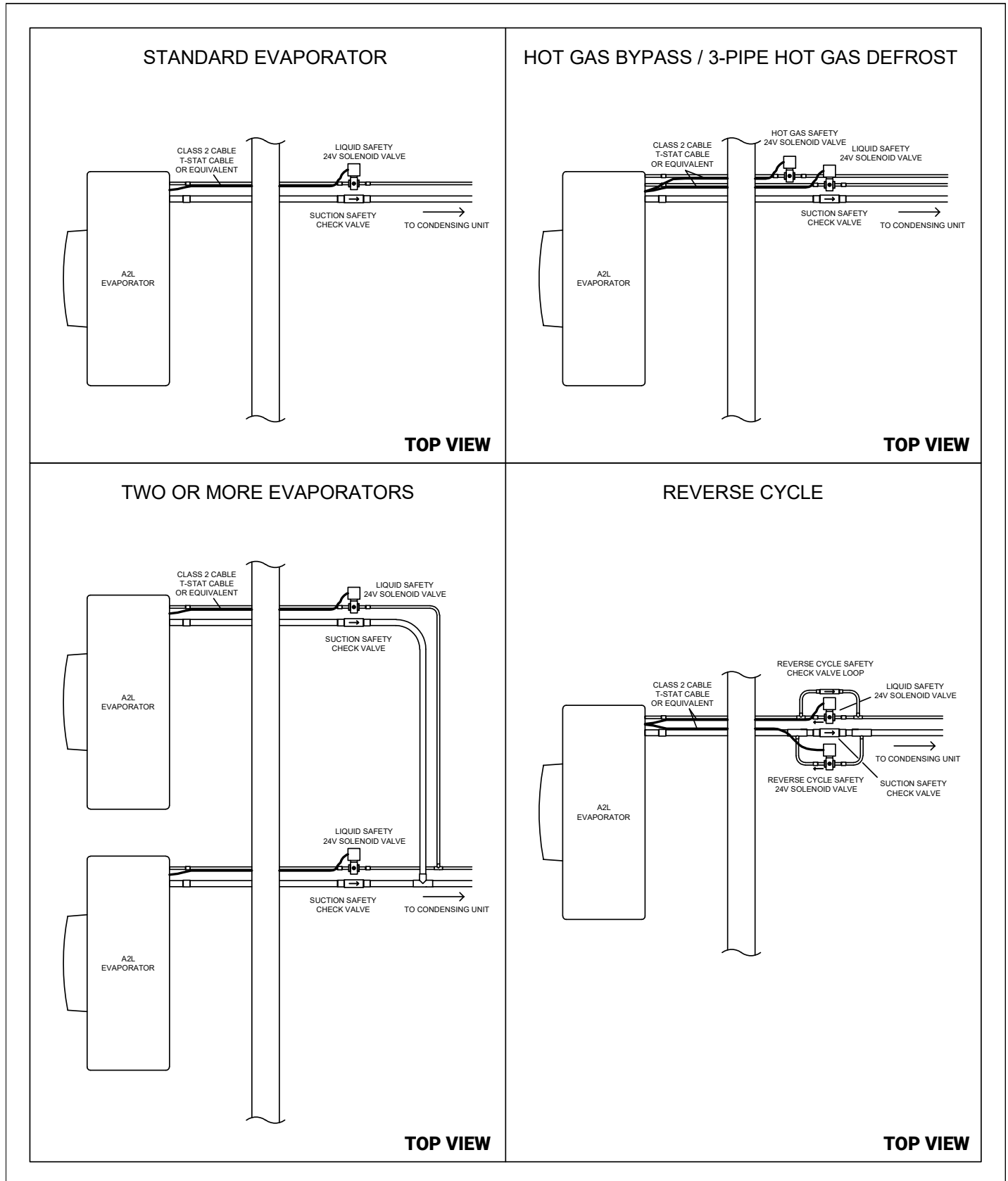

Follow valve manufacturer mounting instructions.

\* Safety Shut-off valve installation in accordance to valve manufacturer requirements.

Standard Configurations - Refer to Nomenclature for details

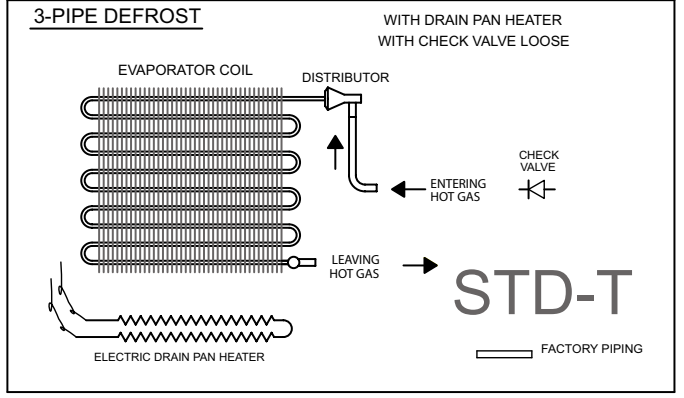
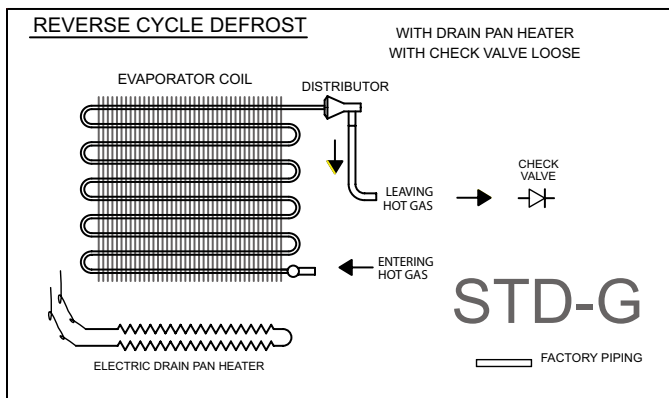
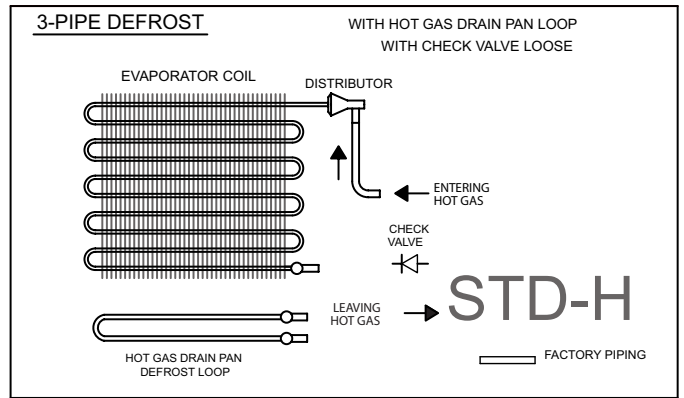
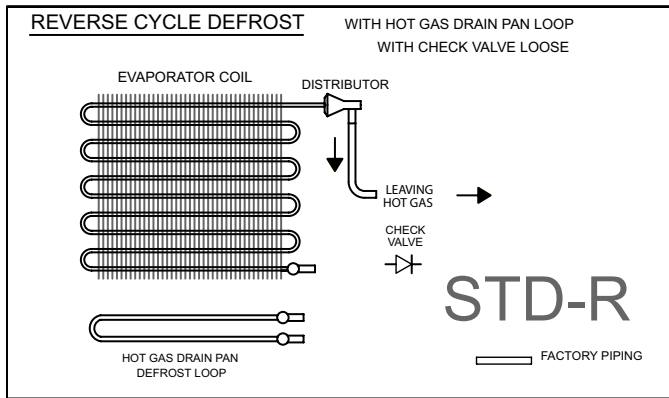

Standard Offering: All Models

Check Valve is included with the coil shipped loose as it is a must have component for system operation.

Check Valve & TXV - See next page (OPT 1)

When a TXV is ordered with a HG defrost coil: Its only option will be **Factory Installed**. The bypass check valve will be **factory installed** as well as part of the same option.

- **Reverse Cycle Pan Heater (G Models)** when ordered with TXV & Check Valve:
  - o TXV, Check Valve and bypass Tee are factory installed
- **Reverse Cycle Pan Loop (R Models)** when ordered with TXV & Check Valve:
  - o TXV, Check Valve and bypass Tee are factory installed
- **3-Pipe Pan Heater (T Models)** when ordered with TXV & Check Valve:
  - o TXV and Check Valve are factory installed
- **3-Pipe Pan Loop (H Models)** when ordered with TXV & Check Valve:
  - o TXV and Check Valve are factory installed

Optional Configurations - Refer to Nomenclature for details

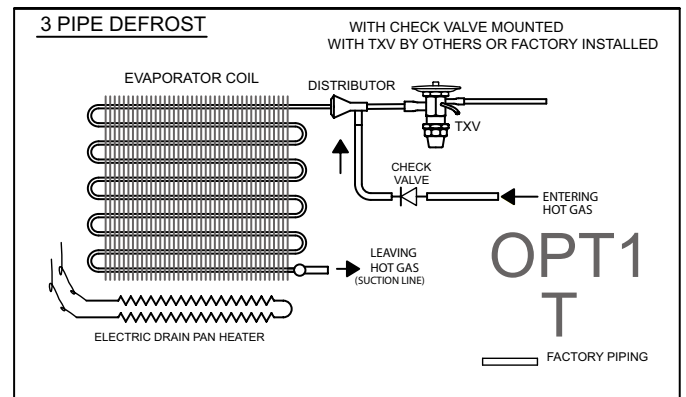
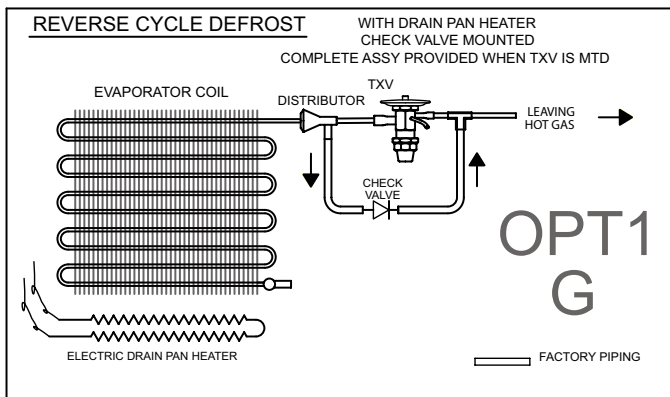
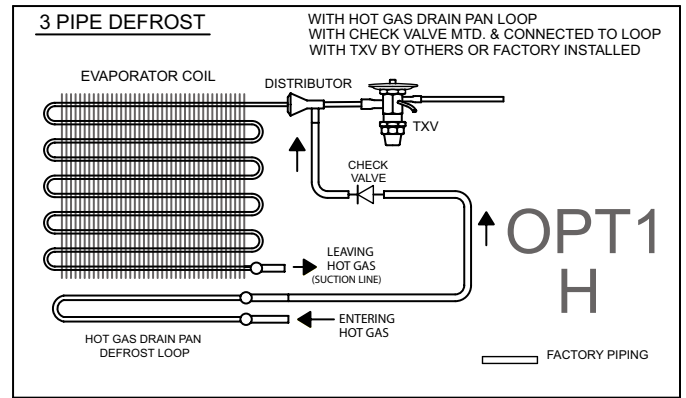
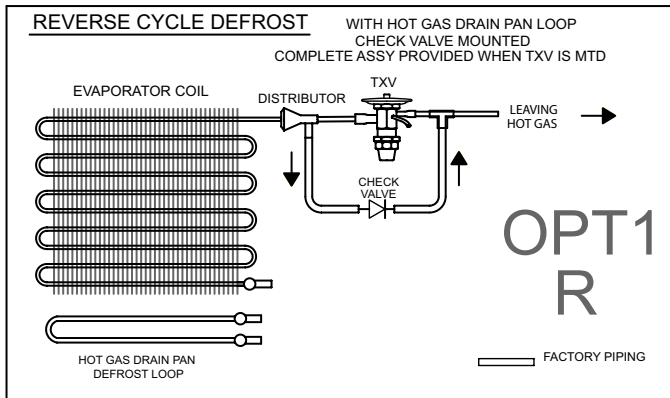

**Drain pan Loop Kit - See below (OPT 2)**

Drain pan loop kit is an assembly that is fully assembled and shipped loose for field installation outside the cabinet. Two check valves are included, depending on the model size, one or both are factory installed.

- **Reverse Cycle Pan Loop (R Models)** when ordered with TXV & Check Valve:
  - o Suction line piping shipped as a pre-piped assembly for field installation

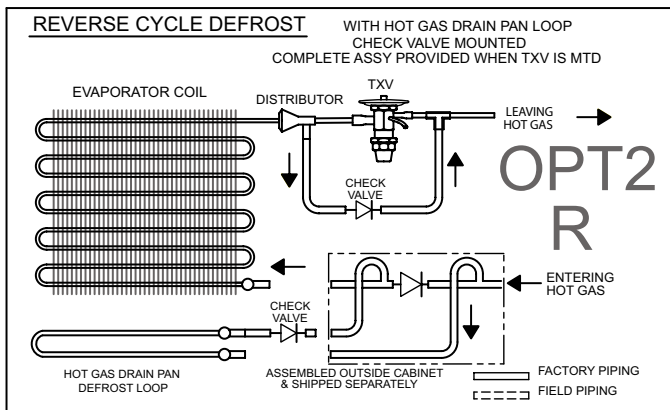

**Solenoid Valve**

Solenoid valves are available as a shipped loose item due to limited space inside the cabinet

Medium Temperature, 6 FPI

TEMP	FPI	# of Fans	Model KLP	Voltage	1 X EVAPORATOR		2 X EVAPORATOR	
					Defrost Kit	Fuse Package	Defrost Kit	Fuse Package
ME - MEDIUM TEMPERATURE	6	1	105ME-S2D	208-230/1/60	DFK-02	FP-004	DFK-06	FP-008
			105ME-T3D	208-230/3/60	DFK-03	FP-013	DFK-07	FP-018
			107ME-S2D	208-230/1/60	DFK-02	FP-004	DFK-06	FP-008
			107ME-T3D	208-230/3/60	DFK-03	FP-013	DFK-07	FP-018
			108ME-S2D	208-230/1/60	DFK-02	FP-004	DFK-06	FP-008
			108ME-T3D	208-230/3/60	DFK-03	FP-013	DFK-07	FP-018
		2	210ME-S2D	208-230/1/60	DFK-02	FP-004	DFK-06	FP-008
			210ME-T3D	208-230/3/60	DFK-03	FP-013	DFK-07	FP-018
			212ME-S2D	208-230/1/60	DFK-02	FP-004	DFK-06	FP-008
			212ME-T3D	208-230/3/60	DFK-03	FP-013	DFK-07	FP-018
			215ME-S2D	208-230/1/60	DFK-02	FP-004	DFK-06	FP-008
			215ME-T3D	208-230/3/60	DFK-03	FP-013	DFK-07	FP-018
		3	318ME-S2D	208-230/1/60	DFK-02	FP-004	DFK-06	FP-008
			318ME-T3D	208-230/3/60	DFK-03	FP-013	DFK-07	FP-018
			322ME-S2D	208-230/1/60	DFK-02	FP-004	DFK-06	FP-008
		4	322ME-T3D	208-230/3/60	DFK-03	FP-013	DFK-07	FP-018
			424ME-S2D	208-230/1/60	DFK-02	FP-006	DFK-06	FP-015
			424ME-T3D	208-230/3/60	DFK-03	FP-013	DFK-07	FP-018
			429ME-S2D	208-230/1/60	DFK-02	FP-006	DFK-06	FP-015
		5	429ME-T3D	208-230/3/60	DFK-03	FP-013	DFK-07	FP-018
			537ME-S2D	208-230/1/60	DFK-02	FP-007	DFK-06	FP-010
		6	537ME-T3D	208-230/3/60	DFK-03	FP-014	DFK-07	FP-019
			644ME-S2D	208-230/1/60	DFK-02	FP-020	DFK-09	FP-021
			644ME-T3D	208-230/3/60	DFK-03	FP-014	DFK-07	FP-019

Low Temperature, 6 FPI

TEMP	FPI	# of Fans	Model KLP	Voltage	1 X EVAPORATOR		2 X EVAPORATOR	
					Defrost Kit	Fuse Package	Defrost Kit	Fuse Package
LE - LOW TEMPERATURE	6	1	104LE-S2D	208-230/1/60	DFK-02	FP-004	DFK-06	FP-008
			104LE-T3D	208-230/3/60	DFK-03	FP-013	DFK-07	FP-018
			105LE-S2D	208-230/1/60	DFK-02	FP-004	DFK-06	FP-008
			105LE-T3D	208-230/3/60	DFK-03	FP-013	DFK-07	FP-018
			106LE-S2D	208-230/1/60	DFK-02	FP-004	DFK-06	FP-008
			106LE-T3D	208-230/3/60	DFK-03	FP-013	DFK-07	FP-018
		2	207LE-S2D	208-230/1/60	DFK-02	FP-004	DFK-06	FP-008
			207LE-T3D	208-230/3/60	DFK-03	FP-013	DFK-07	FP-018
			209LE-S2D	208-230/1/60	DFK-02	FP-004	DFK-06	FP-008
			209LE-T3D	208-230/3/60	DFK-03	FP-013	DFK-07	FP-018
			211LE-S2D	208-230/1/60	DFK-02	FP-004	DFK-06	FP-008
			211LE-T3D	208-230/3/60	DFK-03	FP-013	DFK-07	FP-018
		3	314LE-S2D	208-230/1/60	DFK-02	FP-004	DFK-06	FP-008
			314LE-T3D	208-230/3/60	DFK-03	FP-013	DFK-07	FP-018
			316LE-S2D	208-230/1/60	DFK-02	FP-004	DFK-06	FP-008
			316LE-T3D	208-230/3/60	DFK-03	FP-013	DFK-07	FP-018
		4	418LE-S2D	208-230/1/60	DFK-02	FP-006	DFK-06	FP-015
			418LE-T3D	208-230/3/60	DFK-03	FP-013	DFK-07	FP-018
			421LE-S2D	208-230/1/60	DFK-02	FP-006	DFK-06	FP-015
			421LE-T3D	208-230/3/60	DFK-03	FP-013	DFK-07	FP-018
		5	526LE-S2D	208-230/1/60	DFK-02	FP-007	DFK-06	FP-010
			526LE-T3D	208-230/3/60	DFK-03	FP-014	DFK-07	FP-019
		6	631LE-S2D	208-230/1/60	DFK-02	FP-020	DFK-09	FP-021
			631LE-T3D	208-230/3/60	DFK-03	FP-014	DFK-07	FP-019

Low Temperature, 4 FPI

TEMP	FPI	# of Fans	Model KLP	Voltage	1 X EVAPORATOR		2 X EVAPORATOR	
					Defrost Kit	Fuse Package	Defrost Kit	Fuse Package
VE - LOW TEMPERATURE	4	1	103VE-S2D	208-230/1/60	DFK-02	FP-004	DFK-06	FP-008
			103VE-T3D	208-230/3/60	DFK-03	FP-013	DFK-07	FP-018
			104VE-S2D	208-230/1/60	DFK-02	FP-004	DFK-06	FP-008
			104VE-T3D	208-230/3/60	DFK-03	FP-013	DFK-07	FP-018
			106VE-S2D	208-230/1/60	DFK-02	FP-004	DFK-06	FP-008
			106VE-T3D	208-230/3/60	DFK-03	FP-013	DFK-07	FP-018
		2	207VE-S2D	208-230/1/60	DFK-02	FP-004	DFK-06	FP-008
			207VE-T3D	208-230/3/60	DFK-03	FP-013	DFK-07	FP-018
			208VE-S2D	208-230/1/60	DFK-02	FP-004	DFK-06	FP-008
			208VE-T3D	208-230/3/60	DFK-03	FP-013	DFK-07	FP-018
			211VE-S2D	208-230/1/60	DFK-02	FP-004	DFK-06	FP-008
			211VE-T3D	208-230/3/60	DFK-03	FP-013	DFK-07	FP-018
		3	313VE-S2D	208-230/1/60	DFK-02	FP-004	DFK-06	FP-008
			313VE-T3D	208-230/3/60	DFK-03	FP-013	DFK-07	FP-018
			316VE-S2D	208-230/1/60	DFK-02	FP-004	DFK-06	FP-008
			316VE-T3D	208-230/3/60	DFK-03	FP-013	DFK-07	FP-018
		4	418VE-S2D	208-230/1/60	DFK-02	FP-006	DFK-06	FP-015
			418VE-T3D	208-230/3/60	DFK-03	FP-013	DFK-07	FP-018
			421VE-S2D	208-230/1/60	DFK-02	FP-006	DFK-06	FP-015
			421VE-T3D	208-230/3/60	DFK-03	FP-013	DFK-07	FP-018
		5	524VE-S2D	208-230/1/60	DFK-02	FP-007	DFK-06	FP-010
			524VE-T3D	208-230/3/60	DFK-03	FP-014	DFK-07	FP-019
		6	627VE-S2D	208-230/1/60	DFK-02	FP-020	DFK-09	FP-021
			627VE-T3D	208-230/3/60	DFK-03	FP-014	DFK-07	FP-019

For info on matched **KeepRite** condensing units, visit [www.k-rp.com/cu](http://www.k-rp.com/cu)

Defrost Kit & Fuse Package Online Selection Tool: [www.k-rp.com/dfk](http://www.k-rp.com/dfk)

**Defrost Kits**

Number of Evaps.	Kit Part Number	Description
1	DFK-01	Time Clock, HtrCont - 1x 40A (3P), FB 1x 30A (1P)
1	DFK-02	Time Clock, HtrCont - 1x 40A (3P), FB 1x 30A (2P)
1	DFK-03	Time Clock, HtrCont - 1x 40A (3P), FB 1x 30A (3P)
1	DFK-04	Time Clock, HtrCont - 1x 40A (3P), FB 1x 60A (2P)
2	DFK-05	Time Clock, HtrCont - 1x 40A (3P), FB 2x 30A (1P)
2	DFK-06	Time Clock, HtrCont - 1x 40A (3P), FB 2x 30A (2P)
2	DFK-07	Time Clock, HtrCont - 1x 40A (3P), FB 2x 30A (3P)
2	DFK-08	Time Clock, HtrCont - 1x 50A (3P), FB 2x 60A (2P)
2	DFK-09	Time Clock, HtrCont - 1x 50A (3P), FB 2x 30A (2P)
1	DFK-10	Time Clock, HtrCont - 1x 40A (3P), FanCont - 1x 40A (3P), FB 2x 30A (2P)
1	DFK-11	Time Clock, HtrCont - 1x 40A (3P), FanCont - 1x 40A (3P), FB 2x 30A (3P)
2	DFK-12	Time Clock, HtrCont - 1x 40A (3P), FanCont - 1x 40A (3P), FB 4x 30A (2P)
2	DFK-13	Time Clock, HtrCont - 1x 40A (3P), FanCont - 1x 40A (3P), FB 4x 30A (3P)
1	DFK-14	Time Clock, HtrCont - 1x 40A (3P), FanCont - 1x 40A (3P), FB 1x 30A (2P), FB 1x 30A (3P)
1	DFK-15	Time Clock, HtrCont - 1x40A (3P), FanCont - 1x 40A (3P), FB 1x 30A (2P), FB 1x 60A (2P)
1	DFK-16	Time Clock, HtrCont - 1x 40A (3P), FanCont - 1x 40A (3P), FB 1x 30A (2P), FB 1x 60A (3P)
1	DFK-17	Time Clock, HtrCont - 1x 40A (3P), FanCont - 1x 40A (3P), FB 1x 30A (3P), FB 1x 60A (3P)
2	DFK-18	Time Clock, HtrCont - 1x 40A (3P), FanCont - 1x 40A (3P), FB 2x 30A (2P), FB 2x 30A (3P)
2	DFK-19	Time Clock, HtrCont - 1x 50A (3P), FanCont - 1x 40A (3P), FB 4x 30A (2P)
2	DFK-20	Time Clock, HtrCont - 1x 50A (3P), FanCont - 1x 40A (3P), FB 4x 30A (3P)
1	DFK-21	Time Clock, HtrCont - 1x 50A (3P), FanCont - 1x 40A (3P), FB 1x 30A (2P), FB 1x 60A (2P)
1	DFK-22	Time Clock, HtrCont - 1x 50A (3P), FanCont - 1x 40A (3P), FB 1x 30A (3P), FB 1x 60A (3P)
2	DFK-23	Time Clock, HtrCont - 1x 50A (3P), FanCont - 1x 40A (3P), FB 2x 30A (2P), FB 2x 30A (3P)
2	DFK-24	Time Clock, HtrCont - 1x 50A (3P), FanCont - 1x 40A (3P), FB 2x 30A (3P), FB 2x 60A (3P)
1	DFK-25	Time Clock, HtrCont - 2x 40A (3P), FanCont - 1x 40A (3P), FB 1x 30A (2P), FB 2x 60A (2P)
1	DFK-26	Time Clock, HtrCont - 2x 40A (3P), FanCont - 1x 40A (3P), FB 1x 30A (3P), FB 2x 60A (3P)
2	DFK-27	Time Clock, HtrCont - 2x 40A (3P), FanCont - 1x 40A (3P), FB 2x 30A (2P), FB 2x 60A (2P)
2	DFK-28	Time Clock, HtrCont - 2x 40A (3P), FanCont - 1x 40A (3P), FB 2x 30A (2P), FB 2x 60A (3P)
2	DFK-29	Time Clock, HtrCont - 2x 40A (3P), FanCont - 1x 40A (3P), FB 2x 30A (3P), FB 2x 60A (3P)
2	DFK-30	Time Clock, HtrCont - 2x 40A (3P), FanCont - 1x 50A (3P), FB 2x 30A (2P), FB 2x 60A (3P)
1	DFK-31	Time Clock, HtrCont - 2x 50A (3P), FanCont - 1x 40A (3P), FB 1x 30A (3P), FB 2x 60A (3P)
2	DFK-32	Time Clock, HtrCont - 2x 50A (3P), FanCont - 1x 40A (3P), FB 2x 30A (2P), FB 2x 60A (2P)
2	DFK-33	Time Clock, HtrCont - 2x 50A (3P), FanCont - 1x 40A (3P), FB 2x 30A (3P), FB 2x 60A (3P)
2	DFK-34	Time Clock, HtrCont - 4x 40A (3P), FanCont - 1x 40A (3P), FB 2x 30A (2P), FB 4x 60A (2P)
2	DFK-35	Time Clock, HtrCont - 4x 40A (3P), FanCont - 1x 40A (3P), FB 2x 30A (3P), FB 4x 60A (3P)
2	DFK-36	Time Clock, HtrCont - 4x 40A (3P), FanCont - 1x 50A (3P), FB 2x 30A (2P), FB 4x 60A (2P)
2	DFK-37	Time Clock, HtrCont - 4x 40A (3P), FanCont - 1x 50A (3P), FB 2x 30A (3P), FB 4x 60A (3P)
2	DFK-38	Time Clock, HtrCont - 4x 50A (3P), FanCont - 1x 50A (3P), FB 2x 30A (3P), FB 4x 60A (3P)
1	DFK-39	Time Clock, HtrCont1 - 1x 40A (3P), HtrCont2 - 2x 50A (3P), FanCont - 1x 40A (3P), FB 4x 60A (3P)

NOTE: HtrCont = Heater Contactor, FanCont = Fan Contactor, FB = Fuse Block, (1P), (2P), (3P) = Number of Poles

**Fuse Packages**

Package Part Number	Description
FP-001	FUSES (1) 15AMP
FP-002	FUSES (1) 20AMP
FP-003	FUSES (1) 25AMP
FP-004	FUSES (2) 15AMP
FP-006	FUSES (2) 20AMP
FP-007	FUSES (2) 25AMP
FP-008	FUSES (4) 15AMP
FP-010	FUSES (4) 25AMP
FP-012	FUSES (2) 35AMP
FP-013	FUSES (3) 15AMP
FP-014	FUSES (3) 20AMP
FP-015	FUSES (4) 20AMP
FP-016	FUSES (4) 20AMP (6) 45AMP
FP-017	FUSES (4) 35AMP
FP-018	FUSES (6) 15AMP
FP-019	FUSES (6) 20AMP
FP-020	FUSES (2) 30AMP
FP-021	FUSES (4) 30AMP
FP-022	FUSES (8) 15AMP
FP-023	FUSES (2) 25AMP (3) 50AMP
FP-024	FUSES (2) 20AMP (3) 45AMP
FP-025	FUSES (6) 20AMP (6) 60AMP
FP-026	FUSES (6) 15AMP (12) 40AMP
FP-027	FUSES (6) 15AMP (6) 40AMP
FP-028	FUSES (6) 20AMP (12) 40AMP
FP-029	FUSES (6) 15AMP (6) 50AMP
FP-030	FUSES (6) 15AMP (6) 45AMP
FP-031	FUSES (6) 15AMP (6) 35AMP
FP-032	FUSES (6) 15AMP (6) 30AMP
FP-033	FUSES (6) 25AMP (12) 50AMP
FP-034	FUSES (6) 20AMP (12) 35AMP
FP-035	FUSES (4) 25AMP (6) 50AMP
FP-036	FUSES (6) 25AMP (12) 60AMP
FP-037	FUSES (6) 20AMP (12) 60AMP
FP-038	FUSES (6) 20AMP (12) 50AMP
FP-039	FUSES (6) 20AMP (12) 45AMP
FP-040	FUSES (6) 15AMP (12) 45AMP
FP-041	FUSES (5) 15AMP
FP-042	FUSES (10) 15AMP
FP-043	FUSES (3) 25AMP (6) 60AMP
FP-044	FUSES (3) 20AMP (6) 60AMP
FP-045	FUSES (3) 20AMP (6) 50AMP
FP-046	FUSES (3) 25AMP (6) 45AMP
FP-047	FUSES (3) 15AMP (6) 45AMP
FP-048	FUSES (4) 15AMP (4) 45AMP
FP-049	FUSES (4) 15AMP (4) 40AMP
FP-050	FUSES (3) 15AMP (3) 60AMP
FP-051	FUSES (4) 20AMP (6) 50AMP
FP-052	FUSES (4) 15AMP (6) 45AMP
FP-053	FUSES (4) 15AMP (6) 30AMP

Package Part Number	Description
FP-054	FUSES (3) 15AMP (6) 35AMP
FP-055	FUSES (2) 15AMP (2) 45AMP
FP-056	FUSES (2) 15AMP (2) 40AMP
FP-057	FUSES (2) 20AMP (3) 50AMP
FP-058	FUSES (2) 15AMP (3) 45AMP
FP-059	FUSES (2) 15AMP (3) 30AMP
FP-060	FUSES (2) 15AMP (2) 35AMP
FP-061	FUSES (2) 15AMP (2) 50AMP
FP-062	FUSES (2) 15AMP (2) 60AMP
FP-063	FUSES (2) 15AMP (3) 25AMP
FP-064	FUSES (2) 15AMP (3) 35AMP
FP-065	FUSES (2) 15AMP (3) 40AMP
FP-066	FUSES (2) 15AMP (3) 20AMP
FP-067	FUSES (4) 15AMP (4) 35AMP
FP-068	FUSES (4) 15AMP (4) 50AMP
FP-069	FUSES (4) 15AMP (4) 60AMP
FP-070	FUSES (4) 15AMP (6) 25AMP
FP-071	FUSES (4) 15AMP (6) 35AMP
FP-072	FUSES (4) 15AMP (6) 40AMP
FP-073	FUSES (4) 15AMP (6) 20AMP
FP-074	FUSES (3) 20AMP (3) 60AMP
FP-075	FUSES (3) 20AMP (6) 35AMP
FP-076	FUSES (3) 25AMP (6) 50AMP
FP-077	FUSES (3) 35AMP (9) 45AMP
FP-078	FUSES (3) 15AMP (3) 35AMP
FP-079	FUSES (3) 15AMP (3) 45AMP
FP-080	FUSES (3) 15AMP (3) 50AMP
FP-081	FUSES (3) 20AMP (6) 40AMP
FP-082	FUSES (3) 15AMP (3) 40AMP
FP-083	FUSES (3) 15AMP (6) 40AMP
FP-084	FUSES (6) 15AMP (6) 60AMP
FP-085	FUSES (6) 15AMP (12) 35AMP
FP-086	FUSES (3) 35AMP (3) 45AMP (6) 60AMP
FP-087	FUSES (4) 20AMP (4) 40AMP (4) 50AMP
FP-088	FUSES (4) 15AMP (4) 35AMP (4) 40AMP
FP-089	FUSES (2) 20AMP (2) 40AMP (2) 50AMP
FP-090	FUSES (2) 15AMP (2) 35AMP (2) 40AMP
FP-091	FUSES (2) 20AMP (2) 35AMP (2) 40AMP
FP-092	FUSES (2) 25AMP (2) 40AMP (2) 50AMP
FP-093	FUSES (4) 20AMP (4) 35AMP (4) 40AMP
FP-094	FUSES (6) 15AMP (6) 25AMP
FP-095	FUSES (3) 15AMP (3) 25AMP
FP-096	FUSES (3) 15AMP (3) 30AMP
FP-097	FUSES (4) 15AMP (4) 30AMP
FP-098	FUSES (4) 15AMP (4) 25AMP
FP-099	FUSES (4) 15AMP (4) 20AMP
FP-100	FUSES (2) 15AMP (2) 20AMP
FP-101	FUSES (2) 15AMP (2) 25AMP
FP-102	FUSES (2) 15AMP (2) 30AMP
FP-103	FUSES (4) 25AMP (4) 40AMP (4) 50AMP

NOTE: FUSES 30AMP and Below - Class CC Type, FUSES 35AMP and Above - Class J Type









**PROJECT INFORMATION****KLP - LOW PROFILE EVAPORATORS**

System	
Model Number	Date of Start-Up
Serial Number	Service Contractor
Refrigerant	Phone
Electrical Supply	E-mail

  
PRODUCT SUPPORT

*web:* [www.k-rp.com/klp](http://www.k-rp.com/klp)  
*email:* [evaps@k-rp.com](mailto:evaps@k-rp.com)  
*call:* 1-844-893-3222 x520

  
TROUBLESHOOTING

*email:* [troubleshooting@k-rp.com](mailto:troubleshooting@k-rp.com)  
*call:* 1-844-893-3222 x529

  
SERVICE PARTS

*web:* [www.k-rp.com/parts](http://www.k-rp.com/parts)  
*email:* [parts@k-rp.com](mailto:parts@k-rp.com)  
*call:* 1-844-893-3222 x504

  
WARRANTY

*web:* [www.k-rp.com/warranty](http://www.k-rp.com/warranty)  
*email:* [warranty@k-rp.com](mailto:warranty@k-rp.com)  
*call:* 1-844-893-3222 x507

  
ORDERS

*email:* [orders@k-rp.com](mailto:orders@k-rp.com)  
*call:* 1-844-893-3222 x501

  
SHIPPING

*email:* [shipping@k-rp.com](mailto:shipping@k-rp.com)  
*call:* 1-844-893-3222 x503

**HOW CAN WE HELP YOU?**  
visit [www.k-rp.com/contact](http://www.k-rp.com/contact)

# Service Parts List Label To Be Attached *HERE*



KeepRite Refrigeration  
Brantford, ON • Longview, TX  
1-800-463-9517 info@k-rp.com www.k-rp.com

