



KLV New Generation "D" Low Velocity Evaporator

PRODUCT DATA & INSTALLATION

Bulletin K30-KLVD-PDI-3
Part # 1109282

	<p style="text-align: center;">PRODUCT SUPPORT</p> <p style="text-align: center;">web: www.k-rp.com/klv email: evaps@k-rp.com call: 1-844-893-3222 x520</p>	<p>scan:</p> 
---	--	--

**Air, Electric or Hot Gas
(Reverse Cycle) Defrost**

Electrical Power:
115/1/60, 208-230/1/60



INCLUDES MODELS FOR DOE & NRCAN
AWEF-COMPLIANT APPLICATIONS

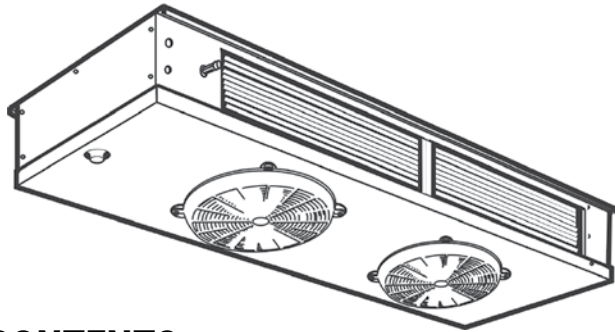

SMARTSPEED™
FAN MOTOR TECHNOLOGY
STANDARD ON ALL MODELS

ESP+
see page 11 for details



CONTENTS

	Page
Nomenclature.....	2
Features & Options.....	2
Selection Data	3 - 4
Electrical Data.....	5 - 6
Wiring Diagrams with standard SMARTSPEED™ EC Motors.....	7 - 10
Wiring Diagrams - Models with ESP+	11 - 14
Annual Walk-In Energy Factor (AWEF) Ratings.....	15
Specifications	15
Dimensional Data.....	16
Installation Clearances.....	17
TXV Selection.....	18
Expansion Valve Selections - Models with ESP+	19
Fan/Heater Control and Defrost Termination Control Position	20
Hot Gas Piping Schematics.....	20
Defrost Kit and Fuse Package Selections / Details	21 - 22
Installation Instructions.....	23 - 24
Project Information.....	26
Product Support Resources: Service Parts, Troubleshooting, Warranty, etc.....	27
"As Built" Service Parts List.....	BACK

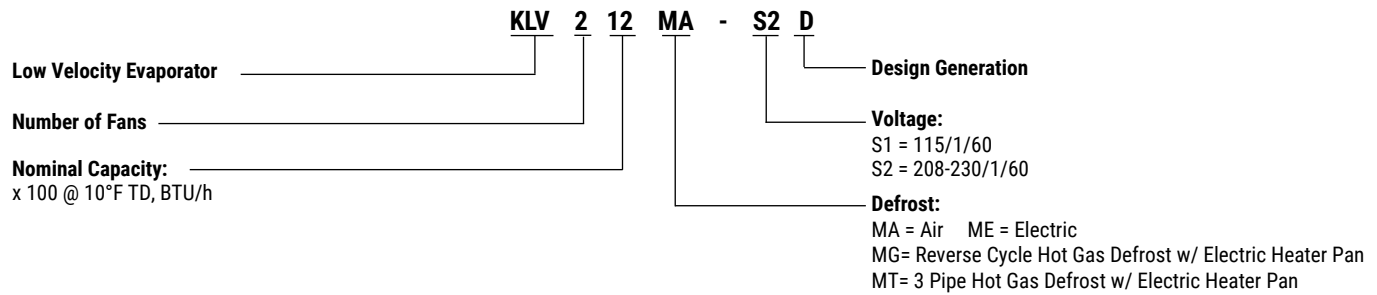

STANDARD FEATURES

- EC motors with patented SmartSpeed® Technology.
- Compatible with Low GWP Refrigerants
- Heavy gauge textured aluminum cabinet construction resists scratches/corrosion and minimizes weight for shipment, installation and service.
- Specially designed for quiet operation - ideal for prep. rooms.
- Dual refrigeration coils with two-way air distribution reduces air velocities to minimize product dehydration.
- Reduced operating charge with 3/8" OD tubing
- Spacious end compartment allows for easy component installation.
- Attractive and durable high-density polypropylene fan guards.
- Hinged drain pan provides convenient access for cleaning.
- Terminal board allows for easy electrical connections.
- Internally enhanced tube

AVAILABLE OPTIONS

- ESP+ Intuitive Evaporator Control Technology. See page 16
- Hot gas loop pan with hot gas defrost models
- Factory installed expansion valve, solenoid valve and room thermostat
- Painted cabinet
- Corrosion protection: alternate fin materials and coatings
- PSC Motors (115, 230 + 460V) - contact factory
- Additional options available, please contact factory

R407A R407C R448A R449A

Medium Temperature - 7 FPI Models

Model KLVD	Qty. Fans	Evaporator Temperature Selection Capacity BTU/h			Air Flow		Refrig. Charge R407A **	
		20/25°F (-4/-7°C)	15°F (-9°C)	10°F (-12°C)	CFM	L/S	LB.	KG
106	1	5990	5930	5870	850	401	2.6	1.2
109		8670	8583	8500	1120	529	4.4	2.0
212	2	12400	12300	12200	1500	708	6.5	2.9
217		17400	17200	17100	2000	944	7.3	3.3
325	3	25200	24900	24700	2785	1314	10.1	4.6
331		31300	31000	30700	3400	1605	9.9	4.5
437	4	37200	36800	36500	4000	1888	11.9	5.4
441		40900	40500	40100	4370	2062	15.2	6.9
546	5	45600	45100	44700	4840	2284	15.2	6.9

- Capacities at other TD within a range of 8 to 15 °F (4.4 to 8.3°C) are directly proportional to TD, or use formula:

Capacity = Rated capacity ÷ 10 x TD.

** For R448A/R449A, use conversion factor 0.96

R404A R507

Medium Temperature - 7 FPI Models

Model KLVD	Qty. Fans	Evaporator Temperature Selection Capacity BTU/h			Air Flow		Refrig. Charge R404A R507	
		20/25°F (-4/-7°C)	15°F (-9°C)	10°F (-12°C)	CFM	L/S	LB.	KG
106	1	4870	4820	4770	850	401	2.4	1.1
109		7040	6970	6900	1120	529	4.0	1.8
212	2	10100	10000	9900	1500	708	6.0	2.7
217		14100	14000	13800	2000	944	6.7	3.0
325	3	20500	20300	20100	2785	1314	9.3	4.2
331		25400	25100	24900	3400	1605	9.1	4.1
437	4	30300	30000	29700	4000	1888	10.9	5.0
441		33300	33000	32600	4370	2062	14.0	6.3
546	5	37000	36600	36300	4840	2284	14.0	6.3

- Capacities at other TD within a range of 8 to 15 °F (4.4 to 8.3°C) are directly proportional to TD, or use formula:

Capacity = Rated capacity ÷ 10 x TD.

115/1/60: Air Defrost

Model KLV	FPI	FAN MOTORS					
		Qty.	Standard SMARTSPEED EC Motors				
			HP	FLA Total	Watts	MCA (A)	Max. Fuse (AMPS)
106MA-S1D	7	1	1/12	1.5	35	1.9	15
109MA-S1D		1	1/12	1.5	95	1.9	15
212MA-S1D		2	1/12	3.0	70	3.4	15
217MA-S1D		2	1/12	3.0	150	3.4	15
325MA-S1D		3	1/12	4.5	225	4.9	15
331MA-S1D		3	1/12	4.5	285	4.9	15
437MA-S1D		4	1/12	6.0	300	6.4	15
441MA-S1D		4	1/12	6.0	380	6.4	15
546MA-S1D		5	1/12	7.5	475	7.9	15

208-230/1/60: Air Defrost

Model KLV	FPI	FAN MOTORS					
		Qty.	Standard SMARTSPEED EC Motors				
			HP	FLA Total	Watts	MCA (A)	Max. Fuse (AMPS)
106MA-S2D	7	1	1/10	1.0	35	1.3	15
109MA-S2D		1	1/10	1.0	95	1.3	15
212MA-S2D		2	1/10	2.0	60	2.3	15
217MA-S2D		2	1/10	2.0	150	2.3	15
325MA-S2D		3	1/10	3.0	225	3.3	15
331MA-S2D		3	1/10	3.0	285	3.3	15
437MA-S2D		4	1/10	4.0	300	4.3	15
441MA-S2D		4	1/10	4.0	380	4.3	15
546MA-S2D		5	1/10	5.0	475	5.3	15

115/1/60: Electric Defrost Models

Model KLV	FPI	FAN MOTORS						DEFROST HEATERS			
		Qty.	Standard SMARTSPEED EC Motors					Total WATTS	115/1/60		
			HP	FLA Total	Watts	MCA (A)	Max. Fuse (AMPS)		Total AMPS	MCA (A)	Max. Fuse (AMPS)
106ME-S1D	7	1	1/12	1.5	35	1.9	15	1880	16.4	20.4	25
109ME-S1D		1	1/12	1.5	95	1.9	15	1880	16.4	20.4	25

208-230/1/60 & 208-230/3/60: Electric Defrost Models

Model KLV	FPI	FAN MOTORS						DEFROST HEATERS						
		Qty.	Standard SMARTSPEED EC Motors					Total WATTS	208-230/1/60			208-230/3/60		
			HP	FLA Total	Watts	MCA (A)	Max. Fuse (AMPS)		Total AMPS	MCA (A)	Max. Fuse (AMPS)	Total AMPS	MCA (A)	Max. Fuse (AMPS)
106ME-*D	7	1	1/10	1.0	35	1.3	15	1880	8.2	10.2	15	4.9	6.1	15
109ME-*D		1	1/10	1.0	95	1.3	15	1880	8.2	10.2	15	4.9	6.1	15
212ME-*D		2	1/10	2.0	60	2.3	15	3180	13.8	17.3	20	8.5	10.6	15
217ME-*D		2	1/10	2.0	150	2.3	15	3180	13.8	17.3	20	8.5	10.6	15
325ME-*D		3	1/10	3.0	225	3.3	15	4540	19.7	24.7	25	12.1	15.1	20
331ME-*D		3	1/10	3.0	285	3.3	15	4540	19.7	24.7	25	12.1	15.1	20
437ME-*D		4	1/10	4.0	300	4.3	15	4540	19.7	24.7	25	12.1	15.1	20
441ME-*D		4	1/10	4.0	380	4.3	15	5580	24.3	30.3	35	14.9	18.6	20
546ME-*D		5	1/10	5.0	475	5.3	15	5580	24.3	30.3	35	14.9	18.6	20

* = S2 or T3. Refer to nomenclature for details.

115/1/60: Hot Gas Defrost

Model KLV	FPI	FAN MOTORS					DRAIN PAN HEATER				
		Qty.	Standard SMARTSPEED [®] EC Motors					Heater Watts	Heater Amps	MCA (A)	Max. Fuse (AMPS)
			HP	FLA Total	Watts	MCA (A)	Max. Fuse (AMPS)				
106 MG/MT	7	1	1/12	1.5	35	1.9	15	580	5.0	6.3	15
109 MG/MT		1	1/12	1.5	95	1.9	15	580	5.0	6.3	15
212 MG/MT		2	1/12	3.0	70	3.4	15	580	5.0	6.3	15
217 MG/MT		2	1/12	3.0	150	3.4	15	580	5.0	6.3	15
325 MG/MT		3	1/12	4.5	225	4.9	15	820	7.1	8.9	15
331 MG/MT		3	1/12	4.5	285	4.9	15	820	7.1	8.9	15
437 MG/MT		4	1/12	6.0	300	6.4	15	820	7.1	8.9	15
441 MG/MT		4	1/12	6.0	380	6.4	15	1020	8.9	11.1	15
546 MG/MT		5	1/12	7.5	475	7.9	15	1020	8.9	11.1	15

208-230/1/60: Hot Gas Defrost

Model KLV	FPI	FAN MOTORS					DRAIN PAN HEATER				
		Qty.	Standard SMARTSPEED [®] EC Motors					Heater Watts	Heater Amps	MCA (A)	Max. Fuse (AMPS)
			HP	FLA Total	Watts	MCA (A)	Max. Fuse (AMPS)				
106 MG/MT	7	1	1/10	1.0	35	1.3	15	580	2.5	3.2	15
109 MG/MT		1	1/10	1.0	95	1.3	15	580	2.5	3.2	15
212 MG/MT		2	1/10	2.0	60	2.3	15	580	2.5	3.2	15
217 MG/MT		2	1/10	2.0	150	2.3	15	580	2.5	3.2	15
325 MG/MT		3	1/10	3.0	225	3.3	15	820	3.6	4.5	15
331 MG/MT		3	1/10	3.0	285	3.3	15	820	3.6	4.5	15
437 MG/MT		4	1/10	4.0	300	4.3	15	820	3.6	4.5	15
441 MG/MT		4	1/10	4.0	380	4.3	15	1020	4.4	5.5	15
546 MG/MT		5	1/10	5.0	475	5.3	15	1020	4.4	5.5	15

115/1/60, 208-230/1/60: Air Defrost Models

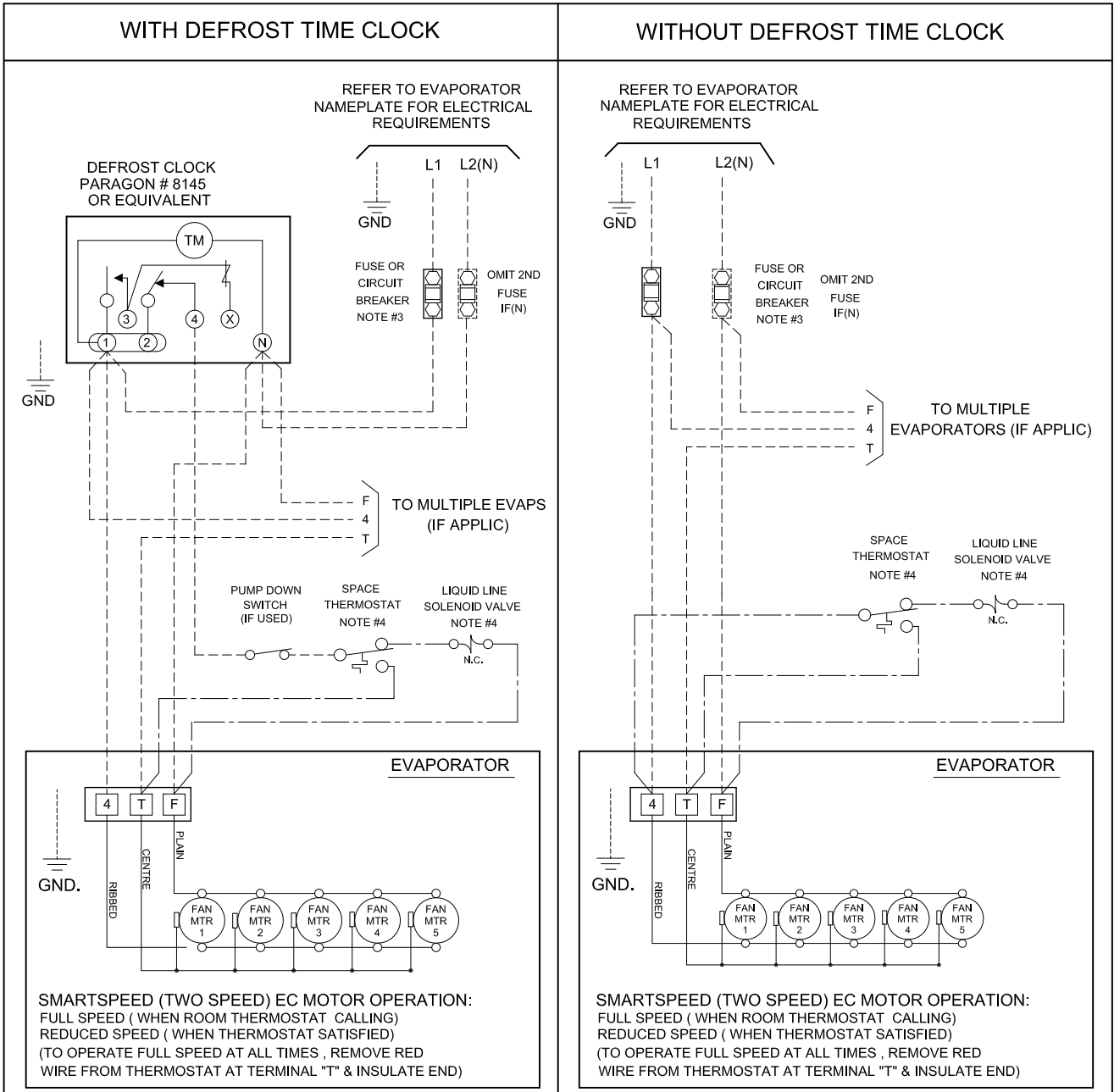

NOTES

- 1). USE COPPER CONDUCTORS ONLY
- 2). USE 90°C WIRE (OR HIGHER)
- 3). OVERCURRENT PROTECTION FOR EVAPORATOR FAN MOTORS MUST NOT EXCEED MAXIMUM VALUE SHOWN ON EVAPORATOR NAMEPLATE.
- 4). MAY BE FACTORY INSTALLED-MOUNTED AND WIRED ON EVAPORATOR .
- 5). REFER TO EVAPORATOR DATA PLATE FOR MOTOR QUANTITY

LV AD 2020-06-26

TERMINALS

- -COMPONENT TERMINAL
- -TERMINAL BLOCK TERMINAL

CONDUCTORS/WIRING

- FACTORY WIRING
- WIRING BY OTHERS
- OPTIONAL FACTORY OR BY OTHERS

ALL FIELD WIRING MUST BE DONE IN COMPLIANCE WITH ALL APPLICABLE LOCAL AND NATIONAL CODES.

208-230/1/60: Electric Defrost Models

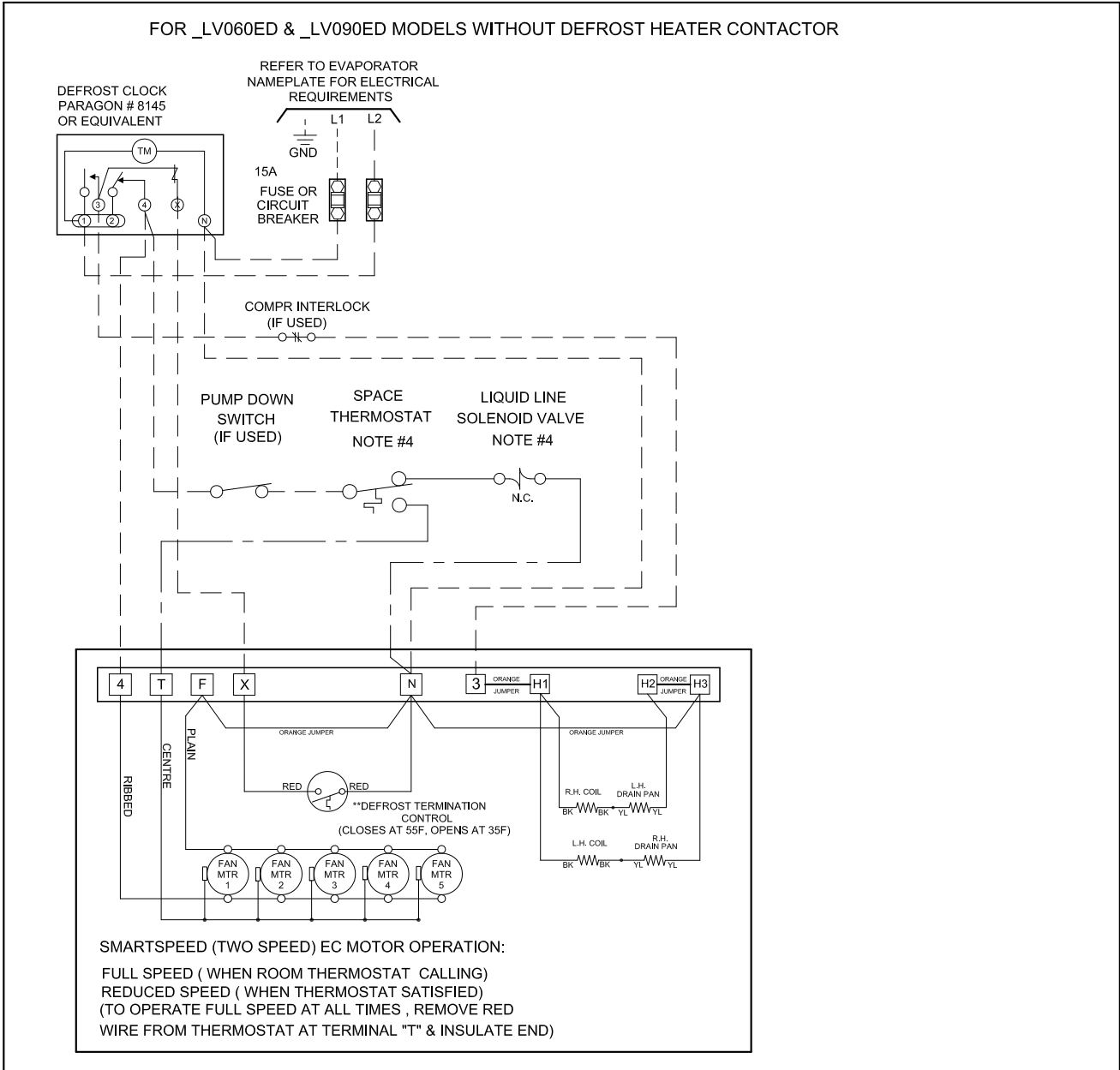

NOTES

- 1). USE COPPER CONDUCTORS ONLY
- 2). USE 90°C WIRE (OR HIGHER)
- 3). OVERCURRENT PROTECTION FOR EVAPORATOR FAN MOTORS AND DEFROST HEATERS MUST NOT EXCEED MAXIMUM VALUE SHOWN ON EVAPORATOR NAMEPLATE.
- 4). MAY BE FACTORY INSTALLED-MOUNTED AND WIRED ON EVAPORATOR
- 5). REFER TO EVAPORATOR DATA PLATE FOR MOTOR QUANTITY

TERMINALS

- -COMPONENT TERMINAL
- -TERMINAL BLOCK TERMINAL

CONDUCTORS/WIRING

- FACTORY WIRING
- - - - - WIRING BY OTHERS
- · - · - · - OPTIONAL FACTORY OR BY OTHERS

ALL FIELD WIRING MUST BE DONE IN COMPLIANCE WITH ALL APPLICABLE LOCAL AND NATIONAL CODES.

LV 106ED-109ED 2020-06-26

208-230/1/60: Electric Defrost Models

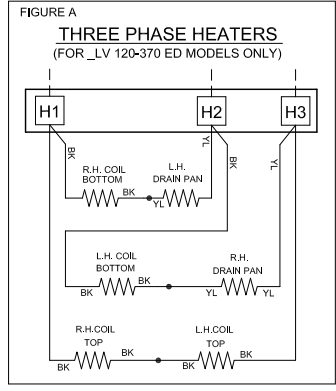
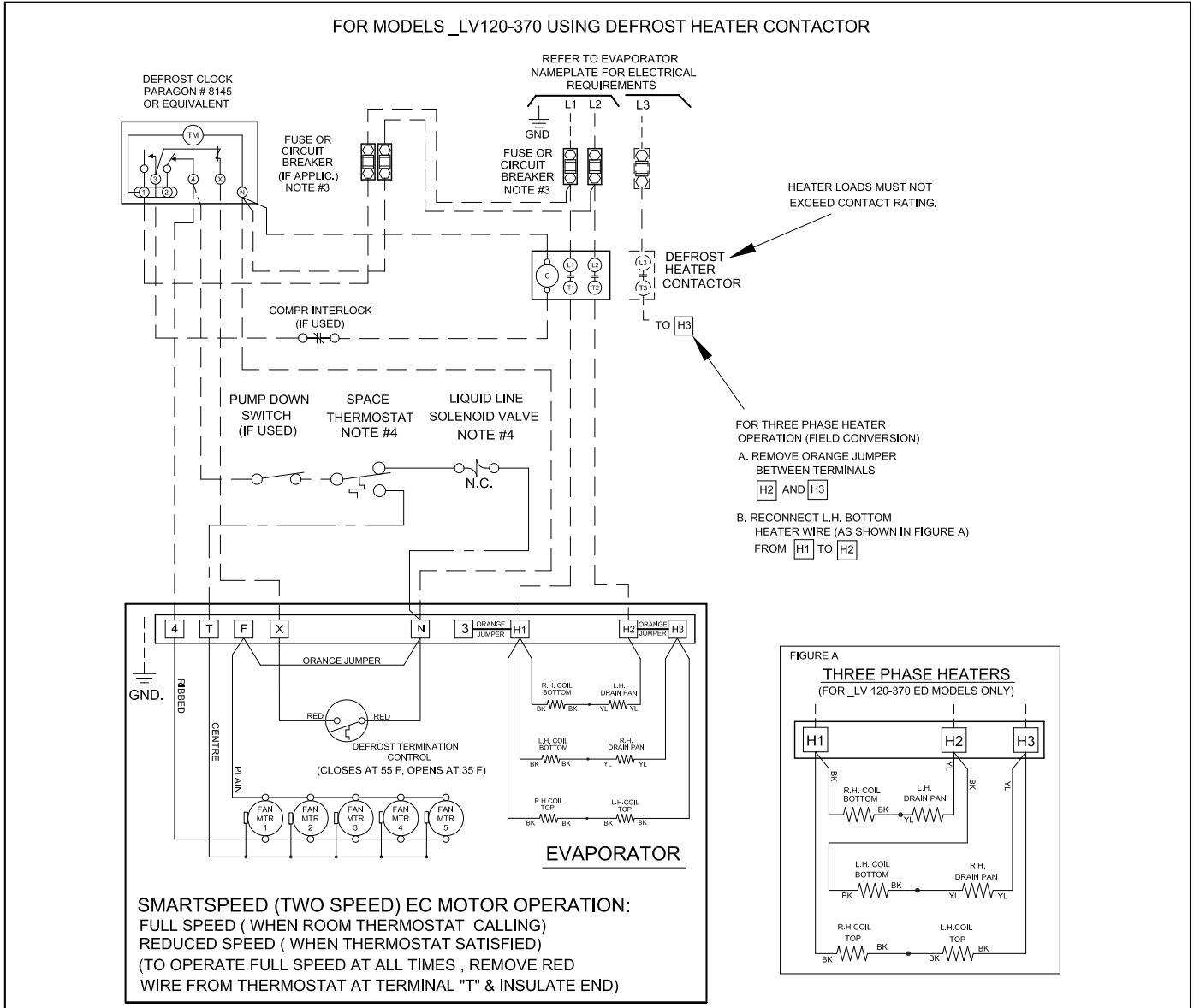

NOTES

- 1). USE COPPER CONDUCTORS ONLY
- 2). USE 90°C WIRE (OR HIGHER)
- 3). OVERCURRENT PROTECTION FOR EVAPORATOR FAN MOTORS AND DEFROST HEATERS MUST NOT EXCEED MAXIMUM VALUE SHOWN ON EVAPORATOR NAMEPLATE.
- 4). MAY BE FACTORY INSTALLED-MOUNTED AND WIRED ON EVAPORATOR
- 5). REFER TO EVAPORATOR DATA PLATE FOR MOTOR QUANTITY

TERMINALS

- -COMPONENT TERMINAL
- -TERMINAL BLOCK TERMINAL

CONDUCTORS/WIRING

- FACTORY WIRING
- - - - - WIRING BY OTHERS
- · - · - · - OPTIONAL FACTORY OR BY OTHERS

ALL FIELD WIRING MUST BE DONE IN COMPLIANCE WITH ALL APPLICABLE LOCAL AND NATIONAL CODES.

208-230/1/60: Electric Defrost Models with Multiple Evaporators

FOR ALL MODELS USING DEFROST HEATER CONTACTOR

REFER TO EVAPORATOR NAMEPLATE FOR ELECTRICAL REQUIREMENTS

SMARTSPEED (TWO SPEED) EC MOTOR OPERATION:
 FULL SPEED (WHEN ROOM THERMOSTAT CALLING)
 REDUCED SPEED (WHEN THERMOSTAT SATISFIED)
 (TO OPERATE FULL SPEED AT ALL TIMES , REMOVE RED
 WIRE FROM THERMOSTAT AT TERMINAL "T" & INSULATE END)

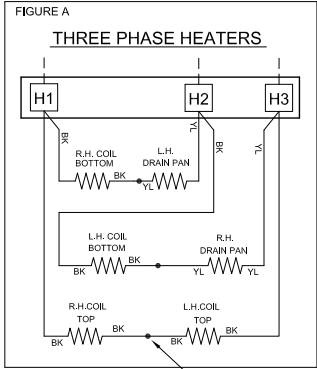
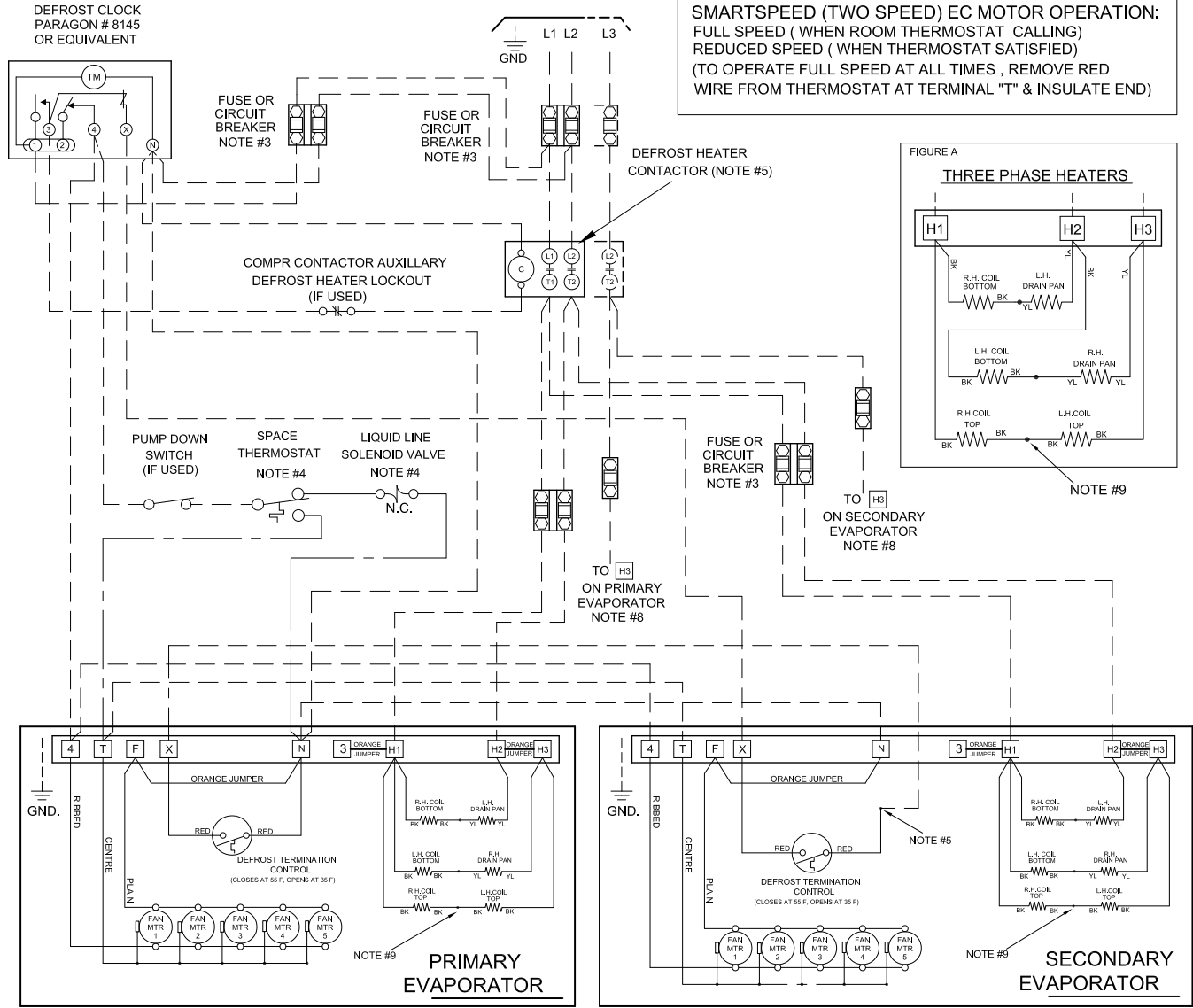

NOTES

- 1). USE COPPER CONDUCTORS ONLY
- 2). USE 90°C WIRE (OR HIGHER)
- 3). OVERCURRENT PROTECTION FOR EVAPORATOR FAN MOTORS AND DEFROST HEATERS MUST NOT EXCEED MAXIMUM VALUE SHOWN ON EVAPORATOR NAMEPLATE
- 4). MAY BE FACTORY INSTALLED-MOUNTED AND WIRED ON EVAPORATOR. (PRE-ASSEMBLED MODELS) ON MULTIPLE PRE-ASSEMBLED EVAPORATORS, WIRE SECOND EVAPORATOR SOLENOID IN PARALLEL WITH FIRST. USE ONLY ONE THERMOSTAT.
- 5). REMOVE RED WIRE FROM TERMINAL [N] AND SPLICE AS SHOWN
- 6). HEATER LOADS MUST NOT EXCEED CONTACTOR RATING
- 7). REFER TO EVAPORATOR DATA PLATE FOR MOTOR QUANTITY
- 8). FOR FIELD CONVERSION TO THREE PHASE HEATERS:
 8a). REMOVE ORANGE JUMPER BETWEEN TERMINALS [H2] AND [H3]
 8b). RECONNECT LH BOTTOM COIL WIRE FROM [H1] TO [H2]. AS SHOWN IN FIGURE A
- 9). TOP HEATER COILS ARE NOT INSTALLED ON _LV060ED & _LV090ED MODELS.

TERMINALS

- -COMPONENT TERMINAL
- -TERMINAL BLOCK TERMINAL

CONDUCTORS/WIRING

- FACTORY WIRING
- - - - - WIRING BY OTHERS
- OPTIONAL FACTORY OR BY OTHERS

ALL FIELD WIRING MUST BE DONE IN COMPLIANCE WITH ALL APPLICABLE LOCAL AND NATIONAL CODES.

ESP+ INTUITIVE EVAPORATOR CONTROL TECHNOLOGY

What is ESP+?

KeepRite Refrigeration's ESP+ intuitive evaporator control technology is designed to replace traditional electro-mechanical refrigeration controls typically used on medium and low temperature applications. By combining award winning adaptive technology along with an electronic expansion valve, KeepRite Refrigeration continues to be The Right Choice For The Refrigeration Professional.

Installing an evaporator utilizing the ESP+ intuitive evaporator control technology is simple. Two pipes, two wires and you're done. No interconnecting control wiring between the evaporator and the condensing unit is required.

- Quick simple installation
- Improved evaporator performance by minimizing excessive frost on the evaporator
 - Eliminates ice build up on surfaces and product
 - Energy savings through evaporator fan management
 - Energy savings with reduction in the number of defrost cycles
 - Defrost heater management
- Improved system diagnostics and service through advanced alarm notification text/email
 - Remote monitoring & system control
 - User friendly interface
 - Precise temperature control for prolonged product shelf life
 - Improved product integrity with less potential for spoilage
 - Downloadable data provides system history for prior 30 days
 - Remotely view and change system parameters and alarm settings
 - Manually control system
 - Easily troubleshoot issues

ESP+ controls:

- Box Temperature
- Superheat
- Liquid Line Solenoid
- Defrost Initiation
- Defrost Termination
- Fan Motors
- Defrost Heater (Electric Defrost Models)

Plus - User can access operating data directly from the system interface

15-20% System Energy Savings over a Properly Commissioned System!

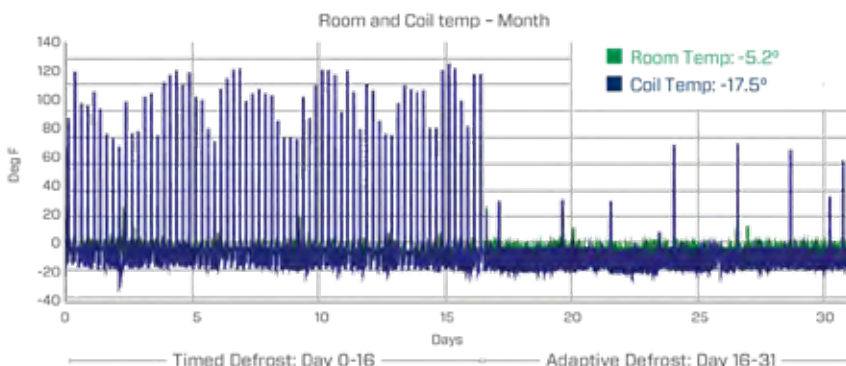

86% Fewer Defrost Cycles*

- Enhanced system performance
- Energy Savings
- Improved product integrity

* Data may vary depending on application

Visit www.k-rp.com/esp for details

Air Defrost Models with ESP

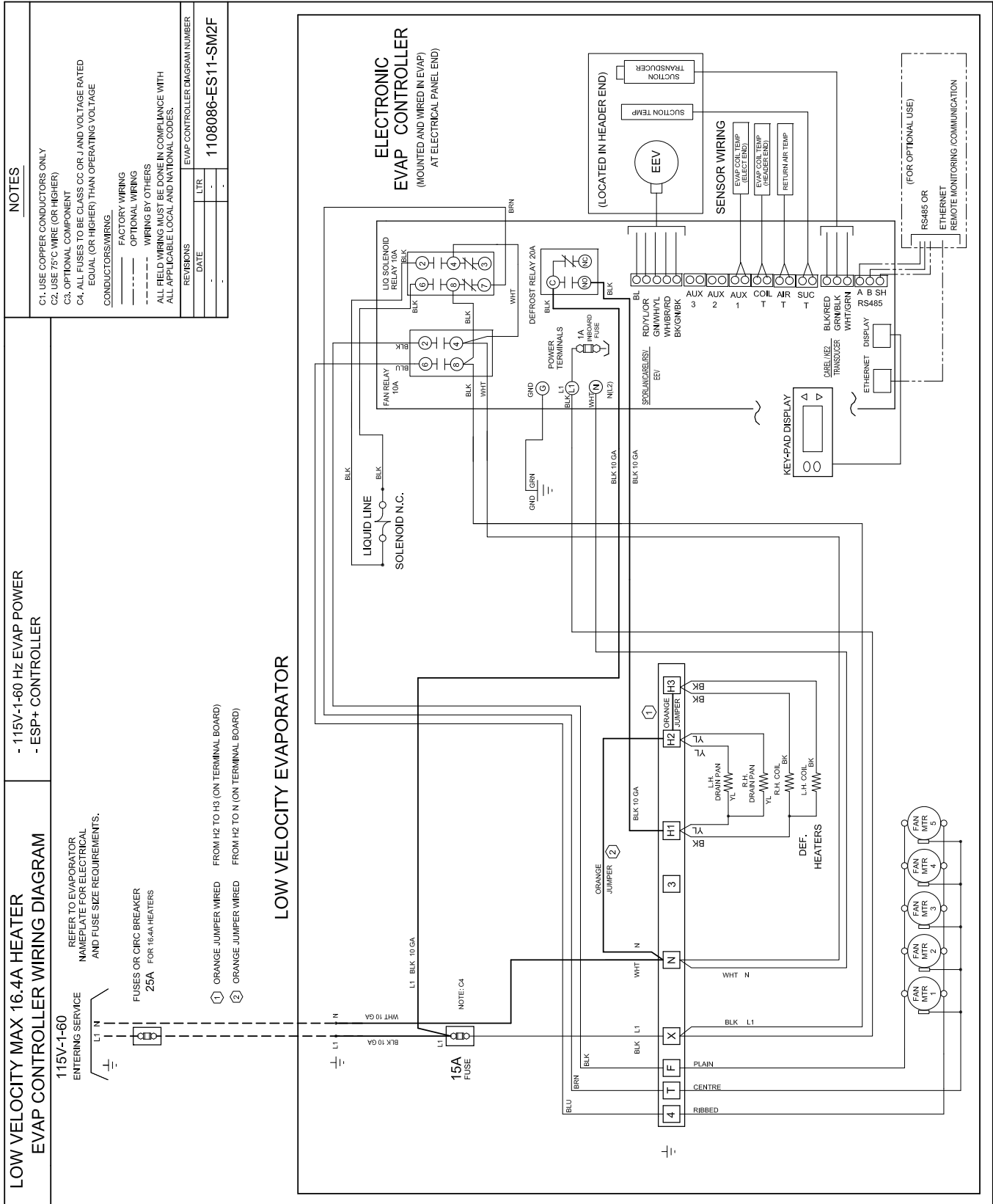

Electric Defrost Models with ESP  Max.12A Heater

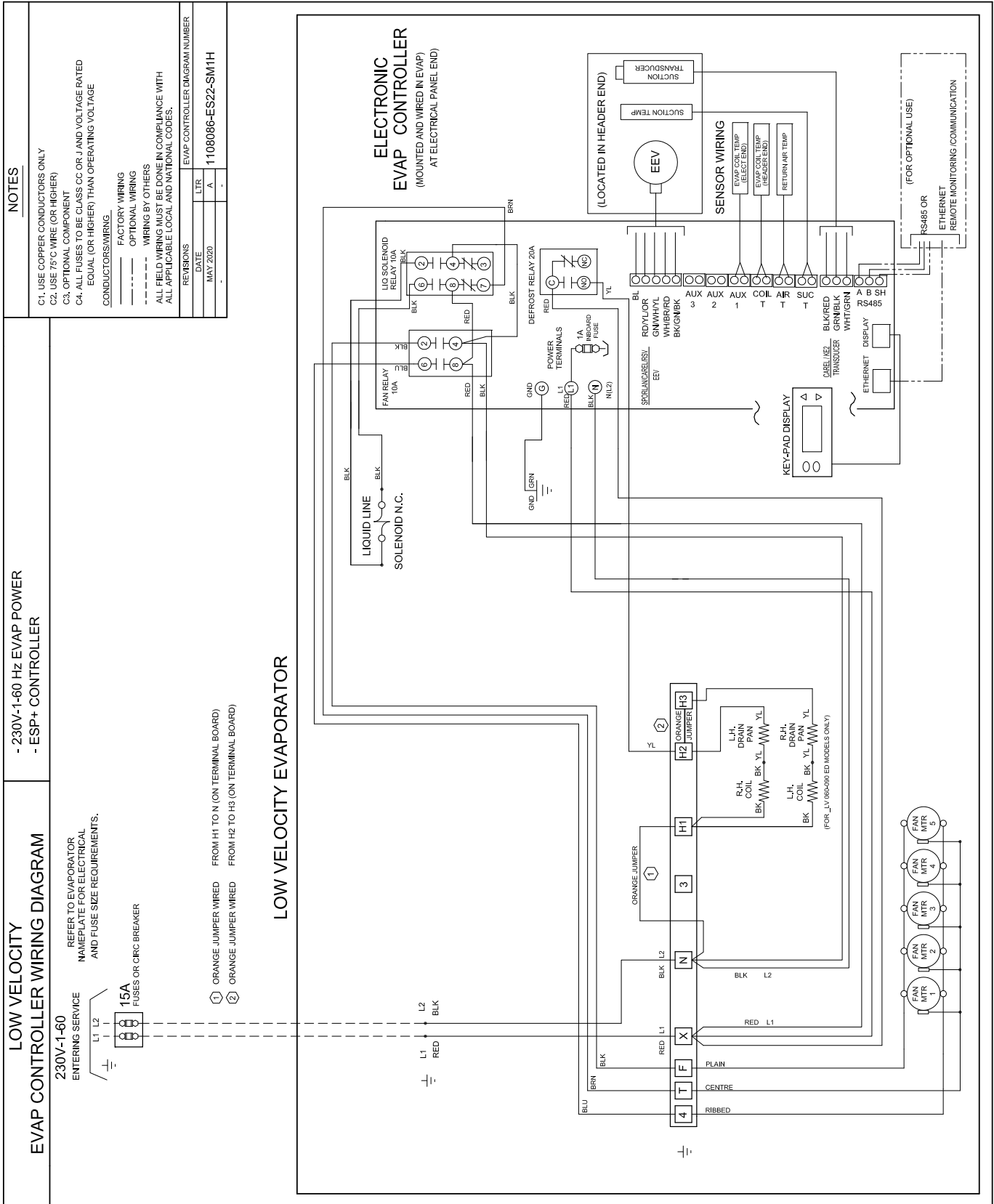

Electric Defrost Models with ESP Max.25A Heater

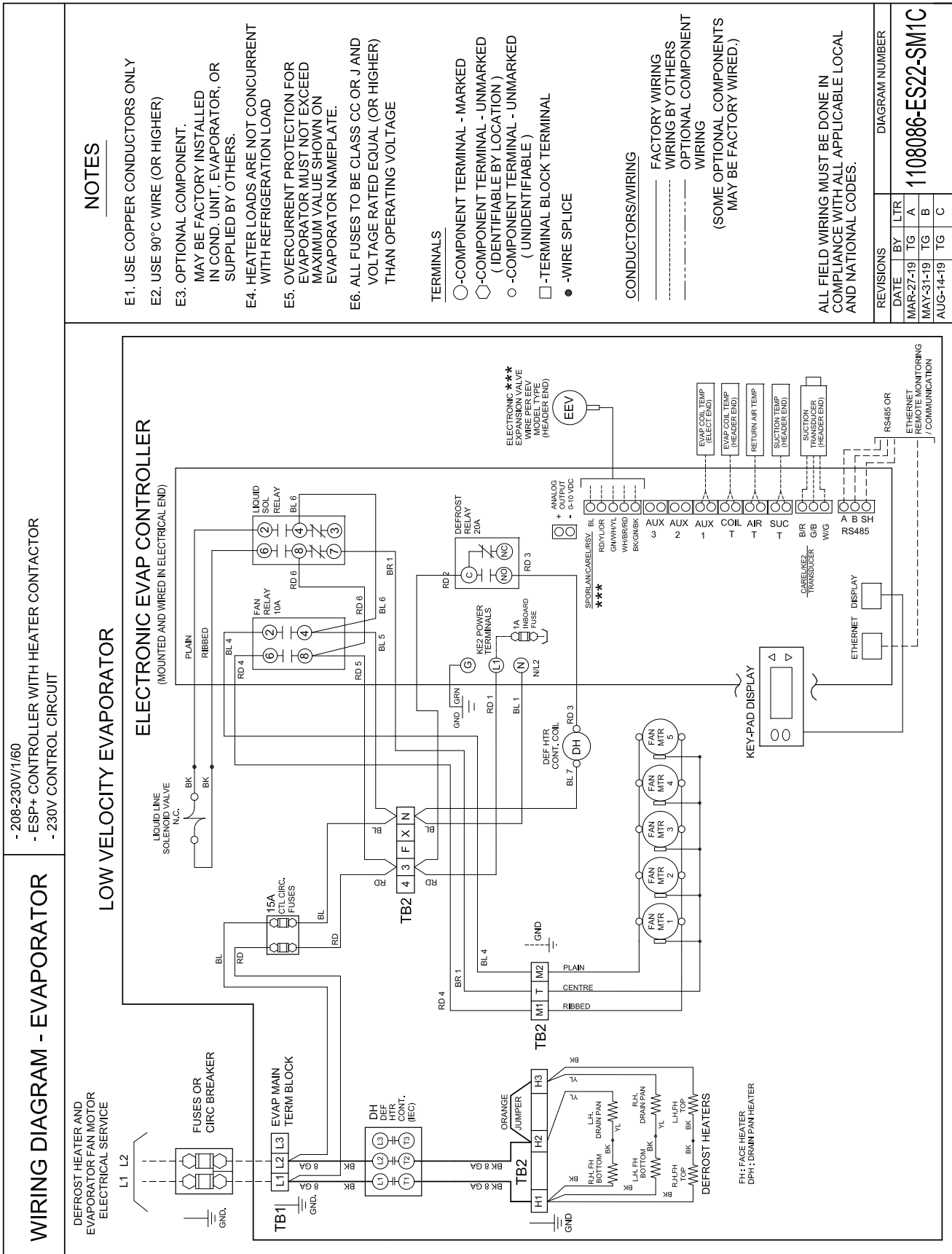

NOTES

- E1. USE COPPER CONDUCTORS ONLY
- E2. USE 90°C WIRE (OR HIGHER)
- E3. OPTIONAL COMPONENT. MAY BE FACTORY INSTALLED IN COND. UNIT, EVAPORATOR, OR SUPPLIED BY OTHERS.
- E4. HEATER LOADS ARE NOT CONCURRENT WITH REFRIGERATION LOAD
- E5. OVERCURRENT PROTECTION FOR EVAPORATOR MUST NOT EXCEED MAXIMUM VALUE SHOWN ON EVAPORATOR NAMEPLATE.
- E6. ALL FUSES TO BE CLASS CC OR J AND VOLTAGE RATED EQUAL (OR HIGHER) THAN OPERATING VOLTAGE

TERMINALS

- - COMPONENT TERMINAL - MARKED
- - COMPONENT TERMINAL - UNMARKED (IDENTIFIABLE BY LOCATION)
- - COMPONENT TERMINAL - UNMARKED (UNIDENTIFIABLE)
- - TERMINAL BLOCK TERMINAL
- - WIRE SPLICE

CONDUCTORS/WIRING

- FACTORY WIRING
 - WIRING BY OTHERS
 - OPTIONAL COMPONENT WIRING
- (SOME OPTIONAL COMPONENTS MAY BE FACTORY WIRED.)

ALL FIELD WIRING MUST BE DONE IN COMPLIANCE WITH ALL APPLICABLE LOCAL AND NATIONAL CODES.

REVISIONS		DIAGRAM NUMBER	
DATE	BY	L	T/R
MAR-27-19	TG	A	B
MAY-31-19	TG	B	A
AUG-14-19	TG	C	C

1108086-ES22-SM1C

208-230/1/60: Electric Defrost Models with ESP Max 14A to 20A Heater

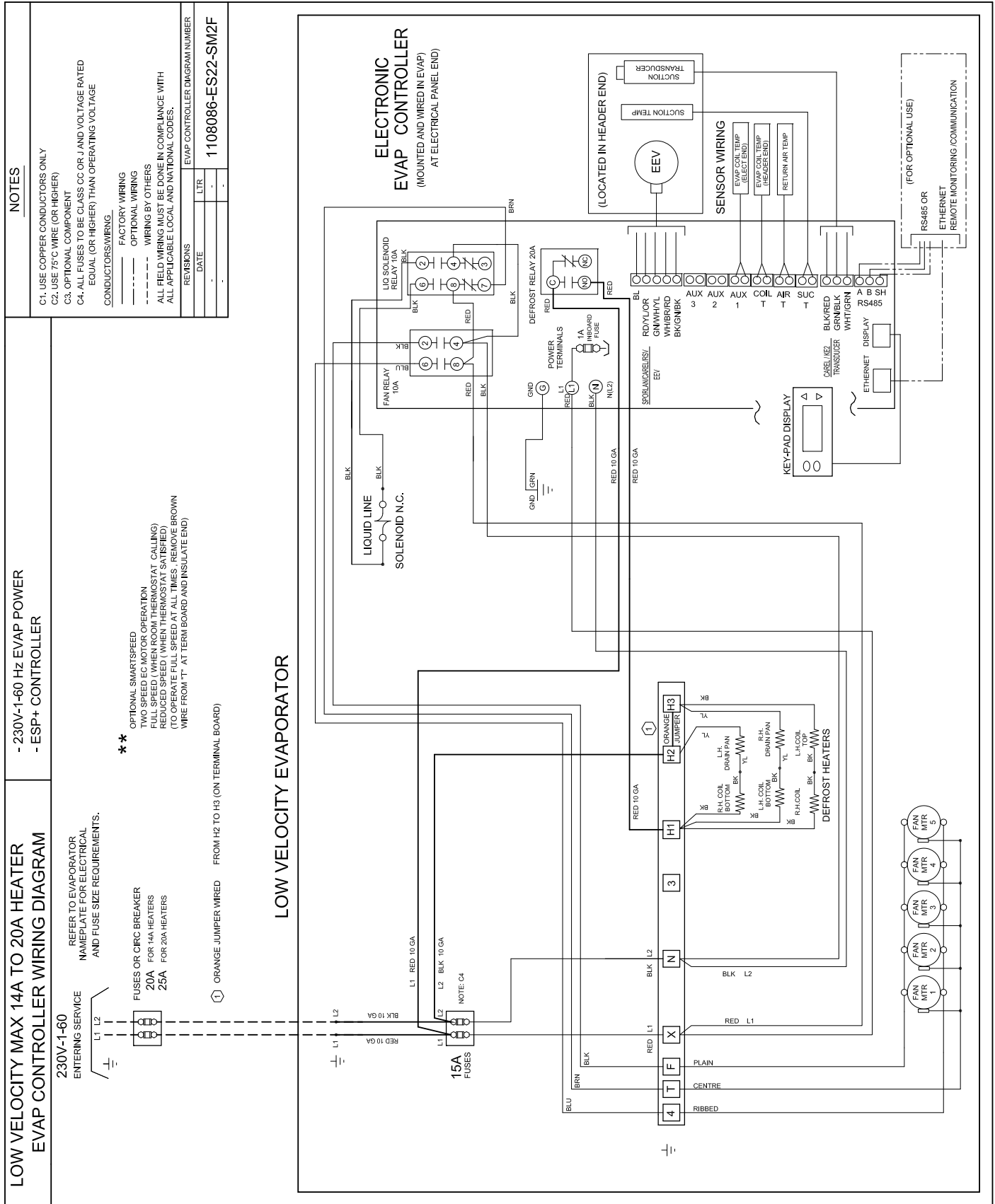

Annual Walk-In Energy Factor Ratings

If a numerical value is listed in the table below, the following statement applies to that corresponding model: " This refrigeration system is designed and certified for use in walk-in cooler applications."

Model KLV	R404A	R407A	R448A
	R507	R407C	R449A
106	9.00	9.00	9.00
109	9.00	9.00	9.00
212	9.00	9.00	9.00
217	9.00	9.00	9.00
325	9.00	9.00	9.00
331	9.00	9.00	9.00
437	9.00	9.00	9.00
441	9.00	9.00	9.00
546	9.00	9.00	9.00

SPECIFICATIONS

MODEL KLV	NO. OF FANS	TUBE CONNECTIONS						SHIPPING WEIGHT	
		SUCTION (OD)		DISTRIBUTOR INLET		HOT GAS SIDE		lbs.	kg
		Inches	mm	Inches	mm	Inches	mm		
106	1	5/8	16	1/2	13	1/2	13	90	41
109		7/8	22	1/2	13	1/2	13	105	48
212	2	7/8	22	1/2	13	1/2	13	139	63
217		1 1/8	29	1/2	13	1/2	13	158	72
325	3	1 1/8	29	1/2	13	1/2	13	235	107
331		1 1/8	29	7/8	22	5/8	16	257	117
437	4	1 1/8	29	7/8	22	5/8	16	270	122
441		1 3/8	35	7/8	22	5/8	16	280	127
546	5	1 3/8	35	7/8	22	5/8	16	290	132

DIMENSIONAL DATA

KLV - LOW VELOCITY EVAPORATORS

- NOTES: 1) Dimensions shown in inches & (mm). These are typical for Air, Electric and Hot gas defrost models.
- 2) Electrical connection end is opposite to the piping end on all models.
- 3) 1/4" (6 mm) O.D. external equalizer line and service access fitting included on all suction headers inside end compartment

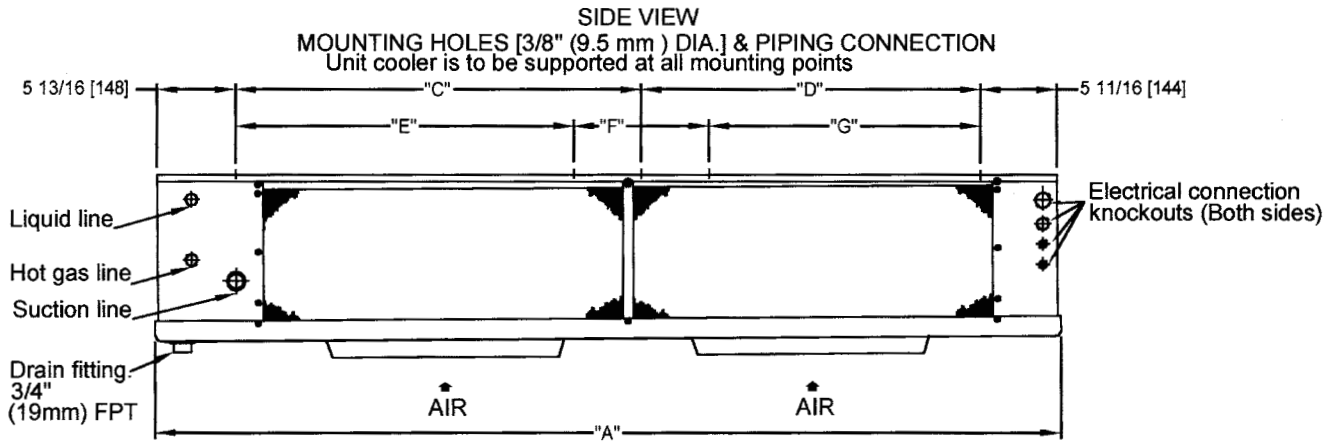
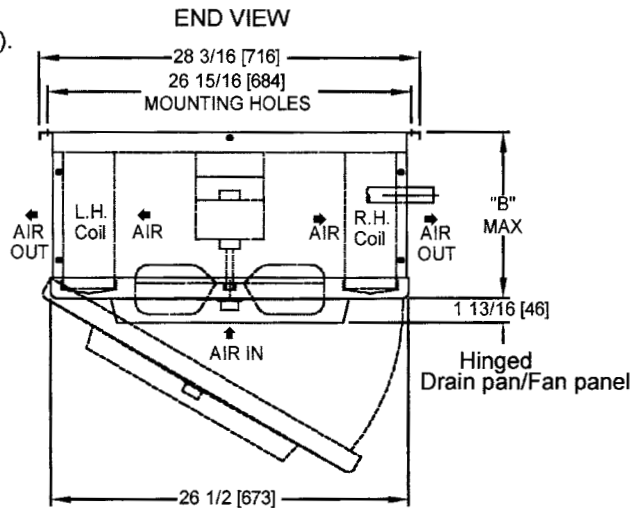

MODEL KLV	NO. OF FANS	A		B		C		D		E		F		G	
		In.	mm	In.	mm	In.	mm	In.	mm	In.	mm	In.	mm	In.	mm
106	1	66 7/8	1699	8 11/16	221	27 1/2	699	27 1/2	699	-	-	-	-	-	-
109		66 7/8	1699	9 9/16	243	27 1/2	699	27 1/2	699	-	-	-	-	-	-
212	2	66 7/8	1699	12 7/16	316	27 1/2	699	27 1/2	699	-	-	-	-	-	-
217		66 7/8	1699	14 15/16	379	27 1/2	699	27 1/2	699	-	-	-	-	-	-
325	3	92 7/8	2359	14 15/16	379	40 1/2	1029	40 1/2	1029	-	-	-	-	-	-
331		92 7/8	2359	17 7/16	443	40 1/2	1029	40 1/2	1029	-	-	-	-	-	-
437	4	92 7/8	2359	17 7/16	443	40 1/2	1029	40 1/2	1029	-	-	-	-	-	-
441		112 7/8	2867	17 7/16	443	-	-	-	-	40 1/2	1029	20	508	40 1/2	1029
546	5	112 7/8	2867	17 7/16	443	-	-	-	-	40 1/2	1029	20	508	40 1/2	1029

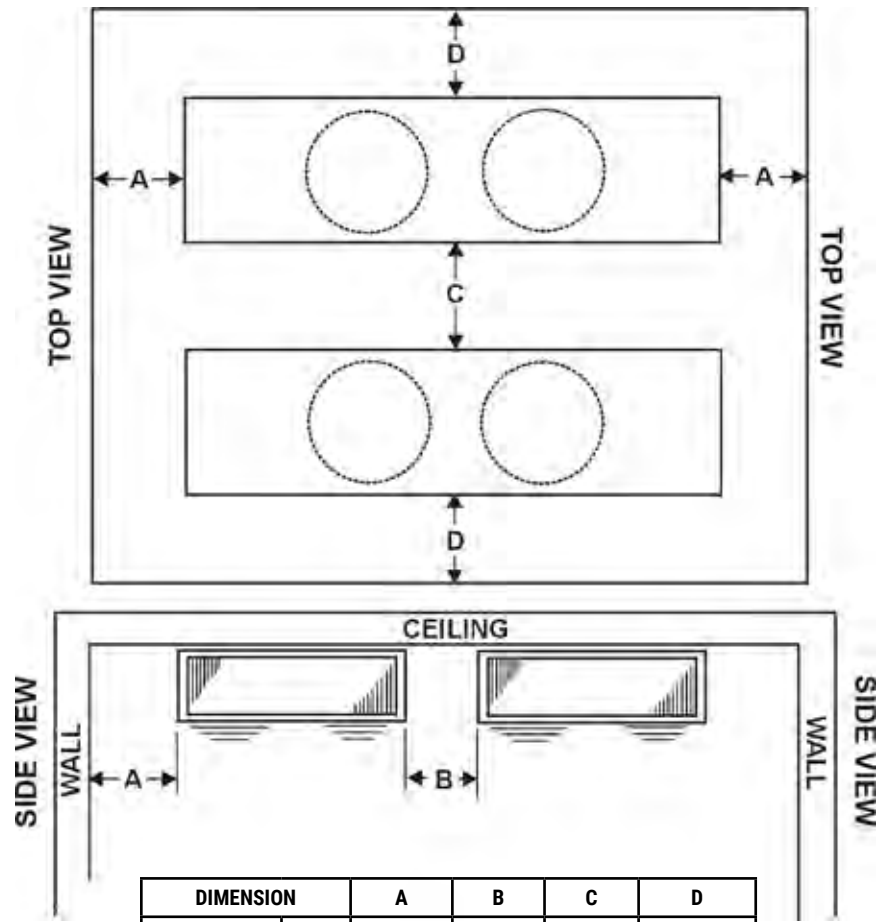

DIMENSION		A	B	C	D
Minimum	ft.	2	2	6	3
	(cm.)	(61)	(61)	(183)	(92)
Maximum	ft.	-	7	40	20
	(cm.)	-	(210)	(1200)	(600)

Medium Temperature

R448A R407C R449A R407A

Air Or Electric Defrost

Model KLV	BTU/h	TD °F	EXPANSION VALVE
106***	5990	10	SBQVE-AA-C
	8990	15	SBQVE-A-C
109***	8670	10	SBQVE-A-C
	13000	15	SBQVE-A-C
212***	12400	10	SBQVE-A-C
	18600	15	SBQVE-B-C
217***	17400	10	SBQVE-B-C
	26100	15	SBQVE-C-C
325***	25200	10	SBQVE-B-C
	37800	15	SBQVE-C-C
331***	31300	10	SBQVE-C-C
	47000	15	ERVE-5-C
437***	37200	10	SBQVE-C-C
	55800	15	ERVE-8-C
441***	40900	10	ERVE-5-C
	61400	15	ERVE-8-C
546***	45600	10	ERVE-5-C
	68400	15	EBSVE-8-C

*** Insert defrost type. See nomenclature for details

Medium Temperature

R404A R507

Air Or Electric Defrost

Model KLV	BTU/h	TD °F	EXPANSION VALVE
106***	4870	10	SBQSE-A-C
	7310	15	SBQSE-A-C
109***	7040	10	SBQSE-A-C
	10600	15	SBQSE-B-C
212***	10100	10	SBQSE-A-C
	15200	15	SBQSE-B-C
217***	14100	10	SBQSE-B-C
	21200	15	SBQSE-C-C
325***	20500	10	SBQSE-B-C
	30800	15	ERSE-4-C
331***	25400	10	SBQSE-C-C
	38100	15	ERSE-6-C
437***	30300	10	ERSE-4-C
	45500	15	ERSE-6-C
441***	33300	10	ERSE-4-C
	50000	15	EBSSE-7 1/2-C
546***	37000	10	ERSE-4-C
	55500	15	EBSSE-7 1/2-C

*** Insert defrost type. See nomenclature for details

DISTRIBUTOR NOZZLE SELECTION

Model KLV	FACTORY INSTALLED NOZZLE
106	J-3/4
109	J-1
212	J-1
217	J-1 1/2
325	G-2 1/2
331	G-3
437	G-3
441	E-4
546	E-4

FACTORY INSTALLED EXPANSION VALVE SELECTIONS KLV - LOW VELOCITY EVAPORATORS

Models with ESP

Medium Temperature

R407A R407C R448A R449A

Air Or Electric Defrost

Model KLV	FACTORY INSTALLED NOZZLE	EXPANSION VALVE	FACTORY INSTALLED LIQUID LINE SOLENOID VALVE
106***	3/4	E2V09	3
109***	1	E2V11	3
212***	1	E2V14	3
217***	1 1/2	E2V18	5
325***	2 1/2	E2V24	6
331***	3	E2V24	6
437***	3	E2V24	6
441***	4	E2V24	6
546***	4	E2V35	9

*** Insert defrost type. See nomenclature for details

Medium Temperature

R404A R507

Air Or Electric Defrost

MODEL KLV	FACTORY INSTALLED NOZZLE	EXPANSION VALVE	FACTORY INSTALLED LIQUID LINE SOLENOID VALVE
106***	3/4	E2V09	3
109***	1	E2V11	3
212***	1	E2V14	3
217***	1 1/2	E2V18	5
325***	2 1/2	E2V24	6
331***	3	E2V24	6
437***	3	E2V24	6
441***	4	E2V35	6
546***	4	E2V35	9

*** Insert defrost type. See nomenclature for details

ESP 

Visit
www.k-rp.com/esp
 for Quick Start Guide, Operation Manual, etc

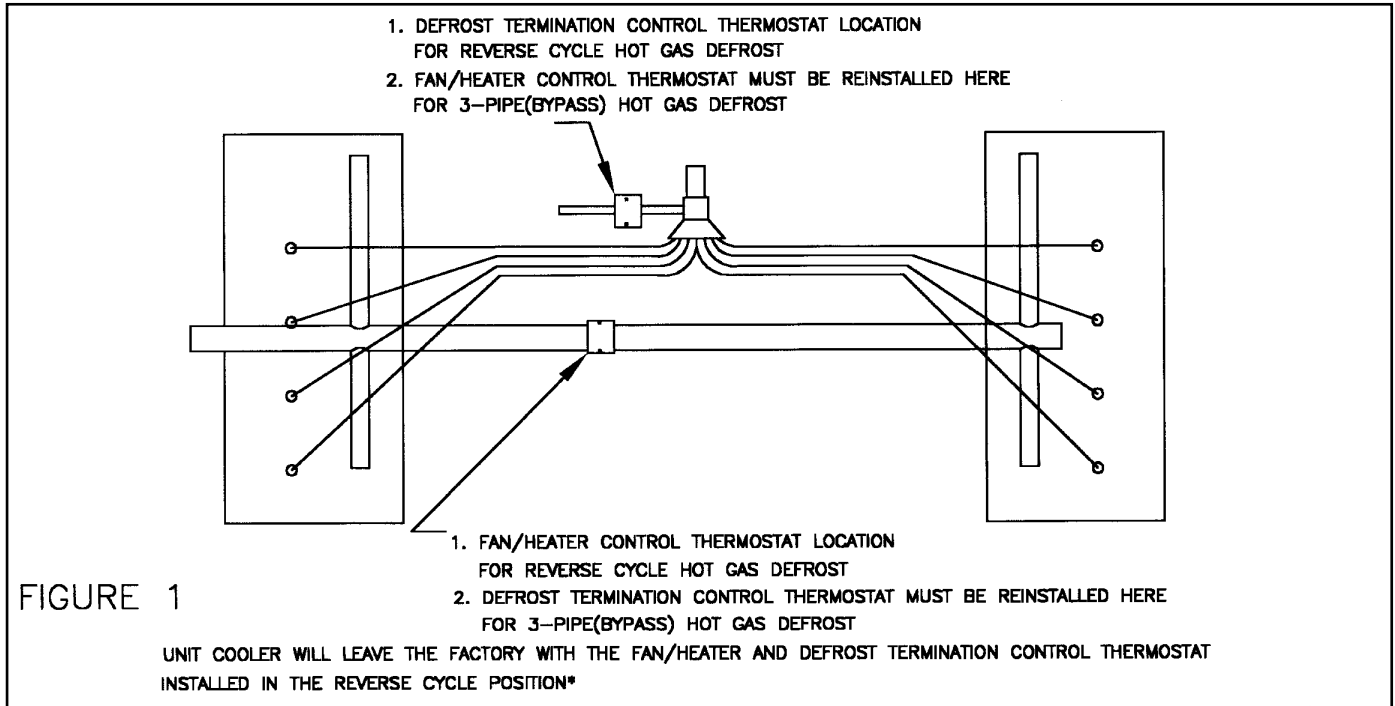

HOT GAS PIPING SCHEMATICS

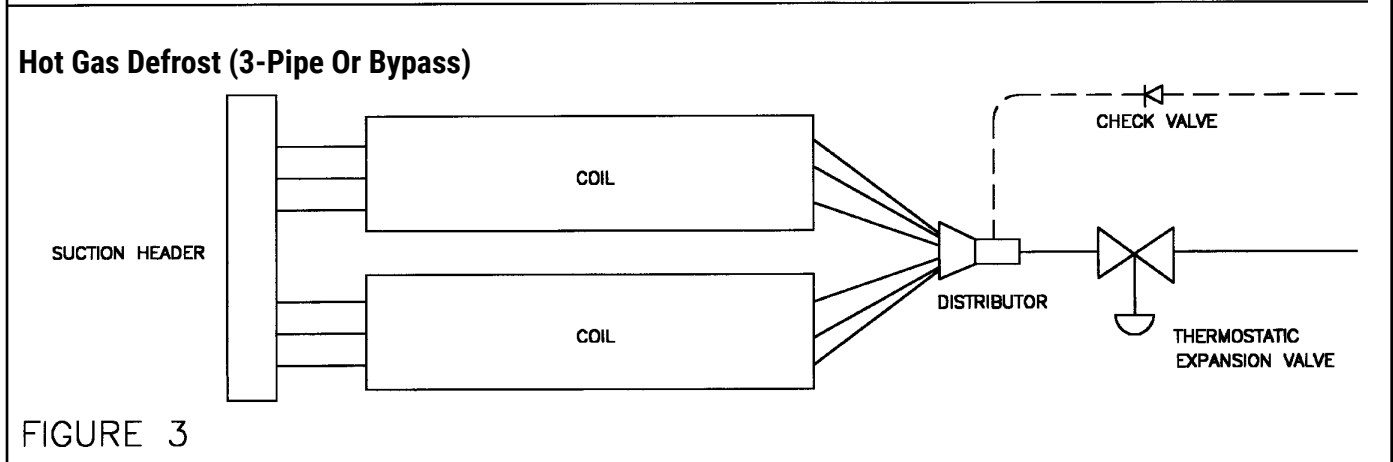
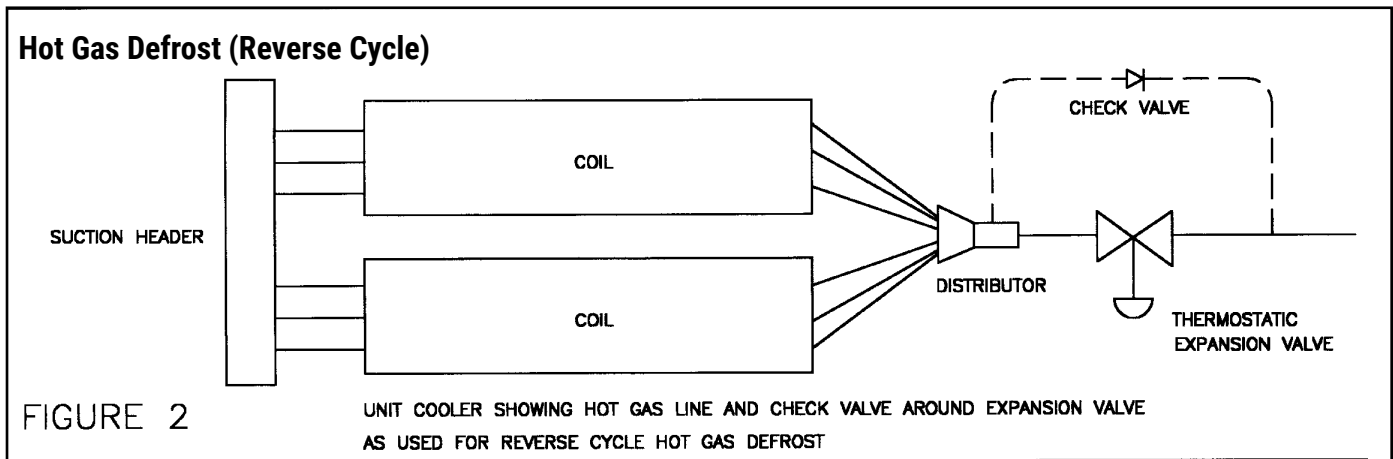

Medium Temperature

TEMP	FPI	# of Fans	Model KLV	Voltage	1 X EVAPORATOR		2 X EVAPORATOR	
					Defrost Kit	Fuse Package	Defrost Kit	Fuse Package
MEDIUM	7	1	106ME-S1D	115/1/60	DFK-01	FP-003	DFK-05	FP-007
			106ME-S2D	208-230/1/60	DFK-02	FP-004	DFK-06	FP-008
			109ME-S1D	115/1/60	DFK-01	FP-003	DFK-05	FP-007
			109ME-S2D	208-230/1/60	DFK-02	FP-004	DFK-06	FP-008
			212ME-S2D	208-230/1/60	DFK-02	FP-006	DFK-06	FP-015
		212ME-S2D	208-230/1/60	DFK-02	FP-006	DFK-06	FP-015	
		325ME-S2D	208-230/1/60	DFK-02	FP-007	DFK-06	FP-010	
		331ME-S2D	208-230/1/60	DFK-02	FP-007	DFK-06	FP-010	
		437ME-S2D	208-230/1/60	DFK-02	FP-007	DFK-06	FP-010	
		441ME-S2D	208-230/1/60	DFK-04	FP-012	DFK-08	FP-017	
	5	546ME-S2D	208-230/1/60	DFK-04	FP-012	DFK-08	FP-017	

Defrost Kits

Number of Evaps.	Kit Part Number	Description
1	DFK-01	Time Clock, HtrCont - 1x 40A (3P), FB 1x 30A (1P)
1	DFK-02	Time Clock, HtrCont - 1x 40A (3P), FB 1x 30A (2P)
1	DFK-03	Time Clock, HtrCont - 1x 40A (3P), FB 1x 30A (3P)
1	DFK-04	Time Clock, HtrCont - 1x 40A (3P), FB 1x 60A (2P)
2	DFK-05	Time Clock, HtrCont - 1x 40A (3P), FB 2x 30A (1P)
2	DFK-06	Time Clock, HtrCont - 1x 40A (3P), FB 2x 30A (2P)
2	DFK-07	Time Clock, HtrCont - 1x 40A (3P), FB 2x 30A (3P)
2	DFK-08	Time Clock, HtrCont - 1x 50A (3P), FB 2x 60A (2P)
2	DFK-09	Time Clock, HtrCont - 1x 50A (3P), FB 2x 30A (2P)
1	DFK-10	Time Clock, HtrCont - 1x 40A (3P), FanCont - 1x 40A (3P), FB 2x 30A (2P)
1	DFK-11	Time Clock, HtrCont - 1x 40A (3P), FanCont - 1x 40A (3P), FB 2x 30A (3P)
2	DFK-12	Time Clock, HtrCont - 1x 40A (3P), FanCont - 1x 40A (3P), FB 4x 30A (2P)
2	DFK-13	Time Clock, HtrCont - 1x 40A (3P), FanCont - 1x 40A (3P), FB 4x 30A (3P)
1	DFK-14	Time Clock, HtrCont - 1x 40A (3P), FanCont - 1x 40A (3P), FB 1x 30A (2P), FB 1x 30A (3P)
1	DFK-15	Time Clock, HtrCont - 1x40A (3P), FanCont - 1x 40A (3P), FB 1x 30A (2P), FB 1x 60A (2P)
1	DFK-16	Time Clock, HtrCont - 1x 40A (3P), FanCont - 1x 40A (3P), FB 1x 30A (2P), FB 1x 60A (3P)
1	DFK-17	Time Clock, HtrCont - 1x 40A (3P), FanCont - 1x 40A (3P), FB 1x 30A (3P), FB 1x 60A (3P)
2	DFK-18	Time Clock, HtrCont - 1x 40A (3P), FanCont - 1x 40A (3P), FB 2x 30A (2P), FB 2x 30A (3P)
2	DFK-19	Time Clock, HtrCont - 1x 50A (3P), FanCont - 1x 40A (3P), FB 4x 30A (2P)
2	DFK-20	Time Clock, HtrCont - 1x 50A (3P), FanCont - 1x 40A (3P), FB 4x 30A (3P)
1	DFK-21	Time Clock, HtrCont - 1x 50A (3P), FanCont - 1x 40A (3P), FB 1x 30A (2P), FB 1x 60A (2P)
1	DFK-22	Time Clock, HtrCont - 1x 50A (3P), FanCont - 1x 40A (3P), FB 1x 30A (3P), FB 1x 60A (3P)
2	DFK-23	Time Clock, HtrCont - 1x 50A (3P), FanCont - 1x 40A (3P), FB 2x 30A (2P), FB 2x 30A (3P)
2	DFK-24	Time Clock, HtrCont - 1x 50A (3P), FanCont - 1x 40A (3P), FB 2x 30A (3P), FB 2x 60A (3P)
1	DFK-25	Time Clock, HtrCont - 2x 40A (3P), FanCont - 1x 40A (3P), FB 1x 30A (2P), FB 2x 60A (2P)
1	DFK-26	Time Clock, HtrCont - 2x 40A (3P), FanCont - 1x 40A (3P), FB 1x 30A (3P), FB 2x 60A (3P)
2	DFK-27	Time Clock, HtrCont - 2x 40A (3P), FanCont - 1x 40A (3P), FB 2x 30A (2P), FB 2x 60A (2P)
2	DFK-28	Time Clock, HtrCont - 2x 40A (3P), FanCont - 1x 40A (3P), FB 2x 30A (2P), FB 2x 60A (3P)
2	DFK-29	Time Clock, HtrCont - 2x 40A (3P), FanCont - 1x 40A (3P), FB 2x 30A (3P), FB 2x 60A (3P)
2	DFK-30	Time Clock, HtrCont - 2x 40A (3P), FanCont - 1x 50A (3P), FB 2x 30A (2P), FB 2x 60A (3P)
1	DFK-31	Time Clock, HtrCont - 2x 50A (3P), FanCont - 1x 40A (3P), FB 1x 30A (3P), FB 2x 60A (3P)
2	DFK-32	Time Clock, HtrCont - 2x 50A (3P), FanCont - 1x 40A (3P), FB 2x 30A (2P), FB 2x 60A (2P)
2	DFK-33	Time Clock, HtrCont - 2x 50A (3P), FanCont - 1x 40A (3P), FB 2x 30A (3P), FB 2x 60A (3P)
2	DFK-34	Time Clock, HtrCont - 4x 40A (3P), FanCont - 1x 40A (3P), FB 2x 30A (2P), FB 4x 60A (2P)
2	DFK-35	Time Clock, HtrCont - 4x 40A (3P), FanCont - 1x 40A (3P), FB 2x 30A (3P), FB 4x 60A (3P)
2	DFK-36	Time Clock, HtrCont - 4x 40A (3P), FanCont - 1x 50A (3P), FB 2x 30A (2P), FB 4x 60A (2P)
2	DFK-37	Time Clock, HtrCont - 4x 40A (3P), FanCont - 1x 50A (3P), FB 2x 30A (3P), FB 4x 60A (3P)
2	DFK-38	Time Clock, HtrCont - 4x 50A (3P), FanCont - 1x 50A (3P), FB 2x 30A (3P), FB 4x 60A (3P)
1	DFK-39	Time Clock, HtrCont1 - 1x 40A (3P), HtrCont2 - 2x 50A (3P), FanCont - 1x 40A (3P), FB 4x 60A (3P)

NOTE: HtrCont = Heater Contactor, FanCont = Fan Contactor, FB = Fuse Block, (1P), (2P), (3P) = Number of Poles

Fuse Packages

Package Part Number	Description
FP-001	FUSES (1) 15AMP
FP-002	FUSES (1) 20AMP
FP-003	FUSES (1) 25AMP
FP-004	FUSES (2) 15AMP
FP-006	FUSES (2) 20AMP
FP-007	FUSES (2) 25AMP
FP-008	FUSES (4) 15AMP
FP-010	FUSES (4) 25AMP
FP-012	FUSES (2) 35AMP
FP-013	FUSES (3) 15AMP
FP-014	FUSES (3) 20AMP
FP-015	FUSES (4) 20AMP
FP-016	FUSES (4) 20AMP (6) 45AMP
FP-017	FUSES (4) 35AMP
FP-018	FUSES (6) 15AMP
FP-019	FUSES (6) 20AMP
FP-020	FUSES (2) 30AMP
FP-021	FUSES (4) 30AMP
FP-022	FUSES (8) 15AMP
FP-023	FUSES (2) 25AMP (3) 50AMP
FP-024	FUSES (2) 20AMP (3) 45AMP
FP-025	FUSES (6) 20AMP (6) 60AMP
FP-026	FUSES (6) 15AMP (12) 40AMP
FP-027	FUSES (6) 15AMP (6) 40AMP
FP-028	FUSES (6) 20AMP (12) 40AMP
FP-029	FUSES (6)15AMP (6) 50AMP
FP-030	FUSES (6) 15AMP (6) 45AMP
FP-031	FUSES (6) 15AMP (6) 35AMP
FP-032	FUSES (6) 15AMP (6) 30AMP
FP-033	FUSES (6) 25AMP (12) 50AMP
FP-034	FUSES (6) 20AMP (12) 35AMP
FP-035	FUSES (4) 25AMP (6) 50AMP
FP-036	FUSES (6) 25AMP (12) 60AMP
FP-037	FUSES (6) 20AMP (12) 60AMP
FP-038	FUSES (6) 20AMP (12) 50AMP
FP-039	FUSES (6) 20AMP (12) 45AMP
FP-040	FUSES (6) 15AMP (12) 45AMP
FP-041	FUSES (5) 15AMP
FP-042	FUSES (10) 15AMP
FP-043	FUSES (3) 25AMP (6) 60AMP
FP-044	FUSES (3) 20AMP (6) 60AMP
FP-045	FUSES (3) 20AMP (6) 50AMP
FP-046	FUSES (3) 25AMP (6) 45AMP
FP-047	FUSES (3) 15AMP (6) 45AMP
FP-048	FUSES (4) 15AMP (4) 45AMP
FP-049	FUSES (4) 15AMP (4) 40AMP
FP-050	FUSES (3) 15AMP (3) 60AMP
FP-051	FUSES (4) 20AMP (6) 50AMP
FP-052	FUSES (4) 15AMP (6) 45AMP
FP-053	FUSES (4) 15AMP (6) 30AMP

Package Part Number	Description
FP-054	FUSES (3)15AMP (6) 35AMP
FP-055	FUSES (2) 15AMP (2) 45AMP
FP-056	FUSES (2) 15AMP (2) 40AMP
FP-057	FUSES (2) 20AMP (3) 50AMP
FP-058	FUSES (2) 15AMP (3) 45AMP
FP-059	FUSES (2) 15AMP (3) 30AMP
FP-060	FUSES (2) 15AMP (2) 35AMP
FP-061	FUSES (2) 15AMP (2) 50AMP
FP-062	FUSES (2) 15AMP (2) 60AMP
FP-063	FUSES (2) 15AMP (3) 25AMP
FP-064	FUSES (2) 15AMP (3) 35AMP
FP-065	FUSES (2) 15AMP (3) 40AMP
FP-066	FUSES (2) 15AMP (3) 20AMP
FP-067	FUSES (4) 15AMP (4) 35AMP
FP-068	FUSES (4) 15AMP (4) 50AMP
FP-069	FUSES (4) 15AMP (4) 60AMP
FP-070	FUSES (4) 15AMP (6) 25AMP
FP-071	FUSES (4) 15AMP (6) 35AMP
FP-072	FUSES (4) 15AMP (6) 40AMP
FP-073	FUSES (4) 15AMP (6) 20AMP
FP-074	FUSES (3) 20AMP (3) 60AMP
FP-075	FUSES (3) 20AMP (6) 35AMP
FP-076	FUSES (3) 25AMP (6) 50AMP
FP-077	FUSES (3) 35AMP (9) 45AMP
FP-078	FUSES (3) 15AMP (3) 35AMP
FP-079	FUSES (3)15AMP (3) 45AMP
FP-080	FUSES (3) 15AMP (3) 50AMP
FP-081	FUSES (3) 20AMP (6) 40AMP
FP-082	FUSES (3) 15AMP (3) 40AMP
FP-083	FUSES (3) 15AMP (6) 40AMP
FP-084	FUSES (6) 15AMP (6) 60AMP
FP-085	FUSES (6) 15AMP (12) 35AMP
FP-086	FUSES (3) 35AMP (3) 45AMP (6) 60AMP
FP-087	FUSES (4) 20AMP (4) 40AMP (4) 50AMP
FP-088	FUSES (4) 15AMP (4) 35AMP (4) 40AMP
FP-089	FUSES (2) 20AMP (2) 40AMP (2) 50AMP
FP-090	FUSES (2) 15AMP (2) 35AMP (2) 40AMP
FP-091	FUSES (2) 20AMP (2) 35AMP (2) 40AMP
FP-092	FUSES (2) 25AMP (2) 40AMP (2) 50AMP
FP-093	FUSES (4) 20AMP (4) 35AMP (4) 40AMP
FP-094	FUSES (6) 15AMP (6) 25AMP
FP-095	FUSES (3) 15AMP (3) 25AMP
FP-096	FUSES (3) 15AMP (3) 30AMP
FP-097	FUSES (4) 15AMP (4) 30AMP
FP-098	FUSES (4) 15AMP (4) 25AMP
FP-099	FUSES (4) 15AMP (4) 20AMP
FP-100	FUSES (2) 15AMP (2) 20AMP
FP-101	FUSES (2) 15AMP (2) 25AMP
FP-102	FUSES (2) 15AMP (2) 30AMP
FP-103	FUSES (4) 25AMP (4) 40AMP (4) 50AMP

NOTE: FUSES 30AMP and Below - Class CC Type, FUSES 35AMP and Above - Class J Type

INSTALLATION

The installation and start-up of LV Evaporators should only be performed by qualified refrigeration mechanics. This equipment should be installed in accordance with all applicable codes, ordinances and local by-laws.

INSPECTION

Inspect all equipment before unpacking for visible signs of damage or loss. Check shipping list against material received to ensure shipment is complete.

IMPORTANT: Remember, you, the consignee, must make any claim necessary against the transportation company. Shipping damage or missing parts, when discovered at the outset, will prevent later unnecessary and costly delays.

If damage or loss during transport is evident, make claim to carrier, as this will be their responsibility, not the manufacturer's.

Should carton be damaged, but damage to equipment is not obvious, a claim should be filed for "concealed damage" with the carrier.

IMPORTANT: The electrical characteristics of the unit should be checked at this time to make sure they correspond to those ordered and to electrical power available at the job site.

Save all shipping papers, tags and instruction sheets for reference by installer and owner.

APPLICATION

LV Unit Coolers are designed for use with a variety of popular refrigerants. At room temperatures above 34°F (1.1°C) (and evaporating temps no lower than 24°F (-4.4°C)) positive coil defrosting (Electric or Hot Gas) is not required. (The air flowing through the coil will accomplish the defrost). At room temperatures of 34°F (1.1°C) and below, positive defrosting is required (either Electric (ED) or Hot Gas (HE, RE, TE) in model nomenclature). These models require the use of (1) Time Clock or equivalent (to initiate and terminate the defrost cycle), and (2) Defrost Termination Control (to prevent unnecessary prolonged heating and steaming of the coil once all the ice and frost has melted), (3) Hot Gas models also utilize a Fan/Heater drain pan control.

The coil must not be exposed to any abnormal atmospheric or acidic environments. This may result in corrosion to the cabinet and possible coil failure (leaks). (Consult manufacturer for optional baked on phenolic protective coatings).

LOCATION

The unit location in the room should be selected to ensure uniform air distribution throughout the entire space to be refrigerated. Be sure that the unit does not draw air in, or blow directly out, through an opened door and that the product does not obstruct the free circulation of air. Allow a minimum of 24" clearance at each end. LV Evaporators draw air through the fans and discharge air through both coils.

Consideration should be given to the coil location in order to minimize the piping run length to the condensing unit and floor drain

EXPANSION VALVE (TXV) SELECTION

All units require the use of an **externally equalized** expansion valve. (A 1/4" (6 mm) O.D. equalizer line has been provided on the coil) TX valves should **not** be selected strictly by their nominal ton rating. (This rating is based at a specific pressure differential and entering liquid temperature). Since applications will differ it is suggested the following selection procedure be followed.

1. Determine actual unit cooler BTUH or KW (thermal). The nominal rating is based at 10 °F T.D. (5.5°C) (Room Temp. minus Evap. Temp.). Note that a higher / lower operating T.D. will increase / decrease this capacity rating by their direct ratio.
2. Determine the pressure drop across the valve by subtracting the suction (evaporating) pressure from the high side liquid pressure. Note: Also subtract the distributor pressure loss (use approx. 25 psig (1.1 bar) for R134a and 35 psig (2.4 bar) for R404A/R507/R22/R407A/R448A).
3. Estimate entering liquid temperature. Temperatures lower than 100°F (37.7°C) increase valve capacity ratings. Refer to valve manufacturer's specs for details.
4. Select valve from the valve manufacturer selection charts for the appropriate refrigerant, evaporating temp and pressure drop.
5. After following the manufacturer's installation instructions and after the room has reached the desired temperature the valve superheat should be checked. This will confirm that the evaporator is operating properly and performing to maximum efficiency. The superheat should be around 5 to 8°F (2.7 to 4.4°C) for a 10 to 12°F (5.5 to 6.6°C) T.D. Too high or low a superheat will result in unsatisfactory system performance and possible compressor problems.

NOZZLE INSTALLATION

All LV Evaporators have nozzles installed at factory. For nozzle selection refer to selection table. In case it is required to install the nozzle at some point in the future, the nozzle retainer clip (in distributor) must be removed before inserting nozzle. Re-install clip ensuring nozzle is properly in place.

MOUNTING

Refer to dimensional drawing for recommended mounting arrangements. Formed mounting channels are provided for flush mounting to the ceiling. Ensure adequate clearance (at least 24" (600 mm)) is provided at each end (to enable access to the electrical and refig. compartments).

Ensure that the ceiling is level since the drain pan has been sloped for drainage during the defrost cycle.

DRAIN LINE

The drain line should be run from the drain connection, sloping at least 1/4" (6 mm) per foot. A trap in a warm area outside the room will allow proper draining through the tubing. Connection should be made to proper drainage facilities that comply with local regulations.

To prevent freeze-up when the temperature of the refrigerated space is 35 °F (1.7 °C) or lower, the drain line should be heated along its run inside the cold room. The heated drain line should be insulated. It is recommended that the heater be energized at all times. A heat input of 20 watts per foot in a 28°F (-2.2°C) room, is satisfactory. Drain line heaters are not required for constant room temperature above 35°F (1.6°C).

Ensure that the drain line has sufficient slope for proper drainage (prevention of ice build up/blockage in pan).

PIPING

Refrigerant line sizes are important and **may not** be the same size as the coil connections. Consult "Recommended refrigerant line sizes" charts in any standard reference book for proper line sizing.

Refrigerant piping and control system should be designed to prevent possible liquid slugging (from oil or refrigerant) of the compressors on start-up after the defrost cycle. On Hot Gas Defrost Systems the suction accumulator should be at least 2.5 times the coils operating charge.

See Dimensional data for line locations. For Reverse Cycle and Hot Gas models and 3-Pipe - see fig. 2 & 3 respectively on page 20 for typical unit piping. These models include a check valve (un-mounted) packaged along with the nozzle in the refrigeration connection compartment end panel.

WIRING

Wire system in accordance with governing standards and local codes. See data and wiring diagrams on pages 7 to 14 for wiring arrangement. Electrical wiring is to be sized in accordance with minimum circuit ampacity rating (MCA).

For ease of identifying the proper wiring terminal, unit wiring is color coded and terminal block connections are identified.

SYSTEM CHECK

Before Start-Up:

1. All wiring should be in accordance with local codes.
2. Refrigerant lines should be properly sized.
3. Off cycle defrost and electric defrost systems preferably must include a liquid line solenoid valve and suction accumulator.
4. Thorough evacuation and, dehydration has been performed.
5. The suction, discharge, and receiver service valves must be open.
6. The system preferably must include a liquid line drier moisture indicator and suction filter.
7. Pour enough water into the drain pan to allow a good check on drainage and seal the trap.

After Start-Up:

1. Check the oil level to be sure the oil charge is correct.
2. On initial start up the fans do not start until coil temperature is pulled down to approximately 35°F (1.7°C) on the hot gas coil. Also, it is normal for the fans to cycle a few times until the room temperature is pulled down.
3. Fan/Heater control and defrost termination control is factory installed for reverse cycle defrost operation. Refer to Fig. 1 on page 20.
4. If coil is to be used for 3-pipe (bypass) Hot Gas Defrost, Fan/Heater must be moved from suction line to hot gas inlet line and the defrost termination control moved to the suction line. Refer to page 20.
5. In general, evaporators running with a TD of 10°F should have a superheat reading of 5 to 8 °F (2.7 to 4.4°C). For evaporators with a higher TD, the superheat should be 8 to 12°F (4.4 to 6.6 °C).
6. Heavy moisture loads are usually encountered when starting the system for the first time. This will cause a rapid build-up of frost on the unit cooler. During the initial pull down, we suggest that the frost build-up be watched and defrosted manually as required. This may be done by rotating the inner dial on the timer until the pin in the outer dial is directly opposite the timer pointer. (Paragon 8145-20 Timer by others).
7. Observe that the system goes through at least one complete DEFROST CYCLE.

MAINTENANCE

The unit should be periodically inspected for any dirt or build-up on the fin surface and cleaned if necessary with a soft whisk or brush. Also ensure coils inner and outer drain pans do not have any ice build-up from improper defrost operation. When replacing heater elements first remove heater retainer brackets and heater clips.



Visit
www.krp.com/esp
 for Quick Start Guide,
 Operation Manual, etc

System	
Model Number	Date of Start-Up
Serial Number	Service Contractor
Refrigerant	Phone
Electrical Supply	E-mail

 <p>PRODUCT SUPPORT</p>	<p><i>web:</i> www.k-rp.com/klv <i>email:</i> evaps@k-rp.com <i>call:</i> 1-844-893-3222 x520</p>
---	--

 <p>TROUBLESHOOTING</p>	<p><i>email:</i> troubleshooting@k-rp.com <i>call:</i> 1-844-893-3222 x529</p>
---	--

 <p>SERVICE PARTS</p>	<p><i>web:</i> www.k-rp.com/parts <i>email:</i> parts@k-rp.com <i>call:</i> 1-844-893-3222 x504</p>
---	--

 <p>WARRANTY</p>	<p><i>web:</i> www.k-rp.com/warranty <i>email:</i> warranty@k-rp.com <i>call:</i> 1-844-893-3222 x507</p>
---	--

 <p>ORDERS</p>	<p><i>email:</i> orders@k-rp.com <i>call:</i> 1-844-893-3222 x501</p>
--	--

 <p>SHIPPING</p>	<p><i>email:</i> shipping@k-rp.com <i>call:</i> 1-844-893-3222 x503</p>
--	--

HOW CAN WE HELP YOU?
visit **www.k-rp.com/contact**

Service Parts List Label To Be Attached *HERE*



KeepRite Refrigeration
Brantford, ON • Longview, TX
1-800-463-9517 info@k-rp.com www.k-rp.com

